

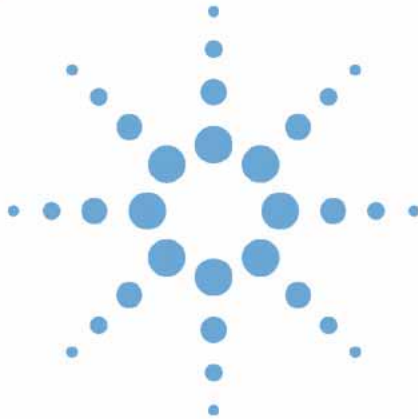

# Agilent 1200 Series Valves



## User Manual

# Notices

© Agilent Technologies, Inc. 2006, 2007

No part of this manual may be reproduced in any form or by any means (including electronic storage and retrieval or translation into a foreign language) without prior agreement and written consent from Agilent Technologies, Inc. as governed by United States and international copyright laws.

## Manual Part Number

G1156-90011

## Edition

11/07

Printed in Germany

Agilent Technologies  
Hewlett-Packard-Strasse 8  
76337 Waldbronn, Germany

## Warranty

**The material contained in this document is provided “as is,” and is subject to being changed, without notice, in future editions. Further, to the maximum extent permitted by applicable law, Agilent disclaims all warranties, either express or implied, with regard to this manual and any information contained herein, including but not limited to the implied warranties of merchantability and fitness for a particular purpose. Agilent shall not be liable for errors or for incidental or consequential damages in connection with the furnishing, use, or performance of this document or of any information contained herein. Should Agilent and the user have a separate written agreement with warranty terms covering the material in this document that conflict with these terms, the warranty terms in the separate agreement shall control.**

## Technology Licenses

The hardware and/or software described in this document are furnished under a license and may be used or copied only in accordance with the terms of such license.

## Restricted Rights Legend

If software is for use in the performance of a U.S. Government prime contract or subcontract, Software is delivered and licensed as “Commercial computer software” as defined in DFAR 252.227-7014 (June 1995), or as a “commercial item” as defined in FAR 2.101(a) or as “Restricted computer software” as defined in FAR 52.227-19 (June 1987) or any equivalent agency regulation or contract clause. Use, duplication or disclosure of Software is subject to Agilent Technologies’ standard commercial license terms, and non-DOD Departments and Agencies of the U.S. Government will receive no greater than Restricted Rights as

defined in FAR 52.227-19(c)(1-2) (June 1987). U.S. Government users will receive no greater than Limited Rights as defined in FAR 52.227-14 (June 1987) or DFAR 252.227-7015 (b)(2) (November 1995), as applicable in any technical data.

## Safety Notices

### CAUTION

A **CAUTION** notice denotes a hazard. It calls attention to an operating procedure, practice, or the like that, if not correctly performed or adhered to, could result in damage to the product or loss of important data. Do not proceed beyond a **CAUTION** notice until the indicated conditions are fully understood and met.

### WARNING

A **WARNING** notice denotes a hazard. It calls attention to an operating procedure, practice, or the like that, if not correctly performed or adhered to, could result in personal injury or death. Do not proceed beyond a **WARNING** notice until the indicated conditions are fully understood and met.

## In This Guide...

The Agilent 1200 Series valves provide the user a comprehensive solutions for more flexibility through solvent selection and column selection. They offer new automation capabilities for sample preparation as well as higher sample throughput with alternating column regeneration. The Agilent 1200 Series valves are fully integrated in the CAN environment (control area network) of the Agilent 1200 Series LC system and can be controlled by the Agilent ChemStation Software. The following types of valves will be described in this manual:

- G1157A Agilent 1200 Series 2 Position/10 Port Valve
- G1158A Agilent 1200 Series 2 Position/ 6 Port Valve
- G1158B Agilent 1200 Series 2 Position/ 6 Port Valve (600bar)
- G1159A Agilent 1200 Series 6 Position Selection Valve
- G1160A Agilent 1200 Series 12 Position/13 Port Selection Valve
- G1162A Agilent 1200 Series 2 Position/ 6 Port Micro Valve
- G1163A Agilent 1200 Series 2 Position/10 Port Micro Valve

These valves and the corresponding capillary kits for alternating column regeneration, sample enrichment, sample clean-up, column selection or solvent selection will allow you to implement these applications easily.

**Chapter 1**, “Installation and Configuration,” starting on page 7 will describe how to install and configure the Agilent 1200 Series valves.

**Chapter 2**, “Operation,” starting on page 17 will describe the Agilent ChemStation valve interface and how to setup the valves in your analytical method.

[Chapter 3](#), “Maintenance, Repair, and Troubleshooting,” starting on page 29 will describe recommended maintenance and repair procedures as well as troubleshooting tools.

[Chapter 4](#), “Valve Applications,” starting on page 43 will describe common application, e.g. alternating column regeneration, and how to setup your valves for these applications.

# Contents

<b>1</b>	<b>Installation and Configuration</b>	<b>7</b>
	Site Requirements	8
	Unpacking the Agilent 1200 Series valve	9
	Damaged Packaging	9
	Delivery Checklist	9
	Hardware Installation	12
	Setting up the CAN connection	13
	Setting up the power connection to other Agilent 1200 Series LC modules	13
	Setting up the power connection to the external power supply	14
	Software Configuration	15
<b>2</b>	<b>Operation</b>	<b>17</b>
	Operating the Valve using Agilent ChemStation	18
	Handheld Controller functions	22
	Valve Control with the 1200 Series Instant Pilot	24
<b>3</b>	<b>Maintenance, Repair, and Troubleshooting</b>	<b>29</b>
	Status Indicators	30
	Maintenance and Repair	31
	Replacing the stator face and the rotor seal for standard valves (G1157A, G1158A, G1159A, G1160A)	32
	Replacing the rotor seal for micro valves (G1162A and G1163A) and the high pressure valve (G1158B)	34
	Early Maintenance Feedback (EMF)	36
	System Errors and Troubleshooting	38
	System Errors	38
	Valve Synchronization	41

## Contents

<b>4</b>	<b>Valve Applications</b>	<b>43</b>
	Alternating Column Regeneration	44
	Sample enrichment and Sample stripping	48
	Sample enrichment	48
	Sample stripping	49
	Automated Configuration Switch for the G1312B RRLC pump	52
	Column Selection	54
	Solvent Selection	56
<b>5</b>	<b>Parts</b>	<b>59</b>
	General Parts	60
	Capillaries and Fittings for analytical and preparative flow rates	62
	Capillaries and Fittings for micro valves	64
<b>6</b>	<b>Specifications</b>	<b>67</b>
<b>7</b>	<b>Safety Information</b>	<b>71</b>
	General Safety Information	72
	Lithium Batteries Information	75
	Radio Interference	76
	Sound Emission	77
	Solvent Information	78
	Agilent Technologies on Internet	79
	<b>Index</b>	<b>81</b>

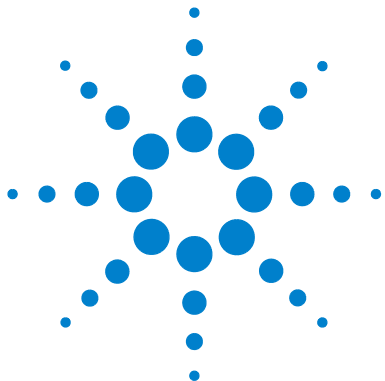

# 1 Installation and Configuration

Site Requirements	8
Unpacking the Agilent 1200 Series valve	9
Hardware Installation	12
Software Configuration	15



## Site Requirements

The requirements for the Agilent 1200 Series Valves are displayed [Table 1](#) and [Table 2](#) on page 8. The 24 Volts DC power can be supplied by an external power supply (0950-4422) or by one of the following Agilent 1200 Series LC modules with DC CAN adapter.

- Agilent 1200 Series preparative pump (G1361A)
- Agilent 1200 Series fraction collectors (G1364A, G1364B, G1364C, G1364D)
- Agilent 1200 Series high performance autosamplers (G1367A, G1367B)
- Agilent 1200 Series micro well-plate autosampler (G1377A)
- Agilent 1200 Series dual-loop autosampler PS (G2258A)

**Table 1** Site Requirements for Agilent 1200 Series Valves

Type	Specification
• Weight	1.9 Kg (4.2 lbs)
• Dimensions • (height x width x depth)	92 x 84 x 200 mm (9.2 x 3.3 x 8.0 inches)
• Power supply	24 Volts DC (1.7 amps)
• Ambient operating temperature	4 to 55°C (39 to 131°F)
• Humidity	< 95%, non-condensing
• Safety Standards	IEC, CSA, UL, EN Installation category II, pollution degree 2 For indoor use only

**Table 2** System Requirements

	Revision
• Agilent 1200 Firmware	A.05.04 and higher
• Control Module Firmware G1323B	B.03.11 and higher
• Agilent ChemStation Software	A.09.03 and higher

## Unpacking the Agilent 1200 Series valve

### Damaged Packaging

If the delivery packaging shows signs of external damage, please call your Agilent Technologies sales and service office immediately. Inform your service representative that the Agilent 1200 Series valve may have been damaged during shipment.

#### CAUTION

If there are signs of damage, please do not attempt to install the valve.

### Delivery Checklist

Ensure all parts and materials have been delivered with the Agilent 1200 Series valve. The delivery checklists are displayed in [Table 3](#) (for G1157A, G1158A, G1158B, G1159A) and in [Table 5](#) (for G1162A, G1163A). Please report missing or damaged parts to your Agilent Technologies sales and service office.

**Table 3** Delivery checklist for Agilent 1200 Series valves G1157A, G1158A, G1158B, G1159A

Quantity	Description	Part Number
1	Agilent 1200 Series Valve	
1	Declaration of conformity	
1	Rail assembly for Column Organizer	
<b>1</b>	<b>Accessory kit containing</b>	
1	• CAN Cable, 1m long	5181-1519
1	• DC-CAN cable	5181-1533
10	• Fitting Screw long	5065-4454
12	• Fitting Screw extra long	5065-9967 (10/pk)

**Table 3** Delivery checklist for Agilent 1200 Series valves G1157A, G1158A, G1158B, G1159A (continued)

Quantity	Description	Part Number
1	• Hex Key 9/64" T-handle	8710-2394
1	• Hex Key 3/32"	
1	• wrench	8710-0510
1	• socket wrench (Rheotool) 1/4	8710-2391

**Table 4** Delivery checklist for Agilent 1200 Series valves G1160A

Quantity	Description	Part Number
1	Agilent 1200 Series Valve	
1	Declaration of conformity	
1	Rail assembly for Column Organizer	
<b>1</b>	<b>Accessory kit containing</b>	
1	• CAN Cable, 1m long	5181-1519
1	• DC-CAN cable	5181-1533
1	• PEEK RheFlex fittings (5/pk)	0100-1631
1	• wrench	8710-0510
1	• Hex Key 9/64"	

**Table 5** Delivery checklist for Agilent 1200 Series micro valves G1162A and G1163A

Quantity	Description	Part Number
1	Agilent 1200 Series Micro Valve	
1	Declaration of conformity	
1	Rail assembly for Column Organizer	5065-4450
6/10	M4 micro valve fittings	5065-4410*
1	M4 micro valve plug	5065-4410†

**Table 5** Delivery checklist for Agilent 1200 Series micro valves G1162A and G1163A

Quantity	Description	Part Number
<b>1</b>	<b>Accessory kit containing</b>	
1	• CAN Cable, 1m long	5181-1519
1	• DC-CAN cable	5181-1533
1	• Hex Key 9/64" T-handle	8710-2394
1	• Hex Key 3/32"	
1	• wrench	8710-0510
1	• socket wrench (Rheotool) 1/4	8710-2391

\* The consumable kit 5065-4410 contains six M4 micro valve fittings.

† The consumable kit 5065-4410 contains two M4 micro valve plugs.

The M4 micro valve fittings support the Agilent PEEK coated fused silica capillaries (O.D. 0.8mm or 1/32"). The M4 micro valve plug is supplied for pressure (leak) testing.

For a list of recommended Agilent PEEK coated fused silica capillaries can be found in the chapter "[Capillaries and Fittings for micro valves](#)" on page 64.

## Hardware Installation

The Agilent 1200 Series valves can be installed in two different ways. They can either be placed on free bench space near the Agilent 1200 Series LC system or they can be mounted on the G1383A Agilent 1200 Series column organizer. The column organizer should be located on the right side of the Agilent 1200 Series stack, which includes the autosampler.

In order to install a valve on the G1383A Column Organizer the Organizer Rail Assembly must be installed on the two mounting poles using the clips from the Organizer Rail Assembly. All External Valves have a bracket on the side which slides over the metal part of the Organizer Rail Assembly.

The G1158B 2 position / 6 port valve (600bar) can be used together with the Pump Configuration Kit G1312-68726 to allow automated switching between different pump configurations. For this application the valve is mounted on a rail at the pump cover, close to pump head in order to reduce delay volume. For more details refer to [Chapter 4](#), “Automated Configuration Switch for the G1312B RRLC pump,” starting on page 52 of this manual.

Two CAN connectors and one DC-CAN connector are located at the back panel of the valve assemblies as displayed in [Figure 1](#).

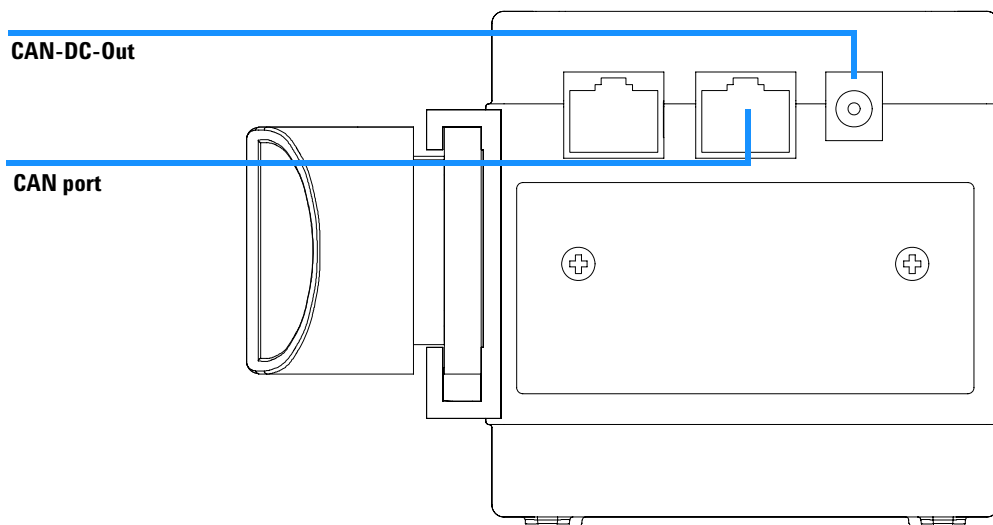

**Figure 1** Back Panel of the Agilent 1200 Series Valves

## Setting up the CAN connection

Connect the CAN-Cable (PN 5181-1519) to one of the CAN ports at back panel of the Agilent 1200 Series valve and to a free CAN-Port on another Agilent 1200 Series module. The second CAN-Port can be used to add additional valves or modules to the LC system.

## Setting up the power connection to other Agilent 1200 Series LC modules

The power for the Agilent 1200 Series valves can be supplied by one of the following Agilent 1200 Series modules:

- Agilent 1200 Series preparative pump (G1361A)
- Agilent 1200 Series fraction collectors (G1364A, G1364B, G1364C, G1364D)
- Agilent 1200 Series high performance autosamplers (G1367B, G1367C)
- Agilent 1200 Series micro well-plate autosampler (G1377A)
- Agilent 1200 Series dual-loop autosampler PS (G2258A)

Connect the DC-CAN Cable (PN 5181-1533) to the DC-CAN connector at the back panel of the valve and to the DC-CAN connector on one of the Agilent 1200 Series modules listed above.

### **Setting up the power connection to the external power supply**

If none of the Agilent 1200 Series modules from the list above is part of your LC system, you have to supply the power through an external power supply (P/N 0950-4422). Plug the DC-CAN adapter from the power supply into the DC-CAN connector on the back panel of your Agilent 1200 Series valve.

## Software Configuration

The Agilent 1200 Series valves can be controlled by the Agilent ChemStation Rev. A.09.03 or higher.

### CAUTION

The maximum number of all modules (including CAN-slave valves) in your Agilent 1200 Series LC system must not exceed 13.

Contact your local sales and service representative to verify, if your configuration is supported. This is especially important, if the number of module is close to 13.

To configure the Agilent 1200 Series valves

Step	Note
1 Start the Agilent ChemStation Software.	
2 Select <b>Configure 1200 Access</b> in the <b>Instrument</b> menu.	
3 In the upcoming <b>Configuration</b> dialog box select one or multiple valves and click <b>Add</b> .	The selected green valve icon now moves from the left <b>Available Modules</b> panel to the right <b>Configured Modules</b> panel as displayed in <a href="#">Figure 2</a> on page 16.
4 Click <b>OK</b> to leave the <b>Configuration</b> dialog box.	
5 After a <b>Restart</b> the Agilent ChemStation Software a new menu item <b>Setup Valve</b> now appears in the <b>Instrument</b> menu.	

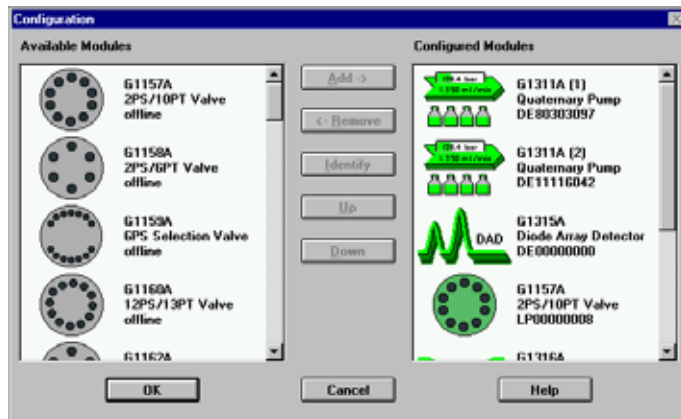
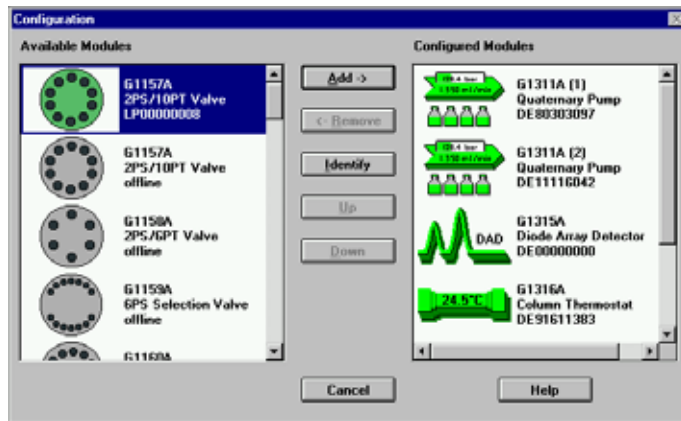
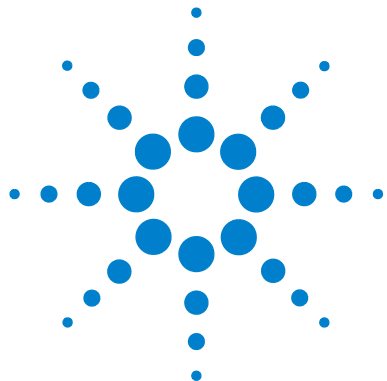

Figure 2 Valve configuration



## 2 Operation

Operating the Valve using Agilent ChemStation	18
Handheld Controller functions	22
Valve Control with the 1200 Series Instant Pilot	24



## Operating the Valve using Agilent ChemStation

After the Agilent 1200 Series Valves have been installed and configured, the valve parameters can be edited in the Agilent ChemStation. Choose **Setup Valve** from the **Instrument** menu to open the valve dialog box as displayed in [Figure 3](#).

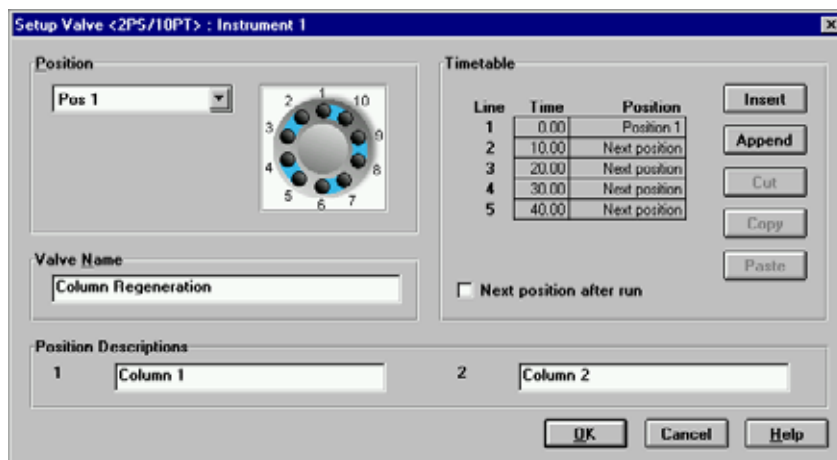

**Figure 3** Valve Setup dialog box

### NOTE

The example displays the valve setup for the 2 position/10 port valve (G1157A). The interface for the other valves are similar.

### Position

When loading a method the valve is switched to the position, that is displayed in the **Position** dropdown box. If you select **Use Current**, the valve remains in the current position, when a new method is loaded.

If you select a new position in the dropdown box and click **OK**, the Setup Valve dialog box will be closed and the valve switches to the new position.

## Operating the Valve using Agilent ChemStation

After the run is finished, the valve always switches to the starting position. If “Use current” is selected, the valve remains in the current position after the run. This behavior is exhibited in Figure 4 on page 19.

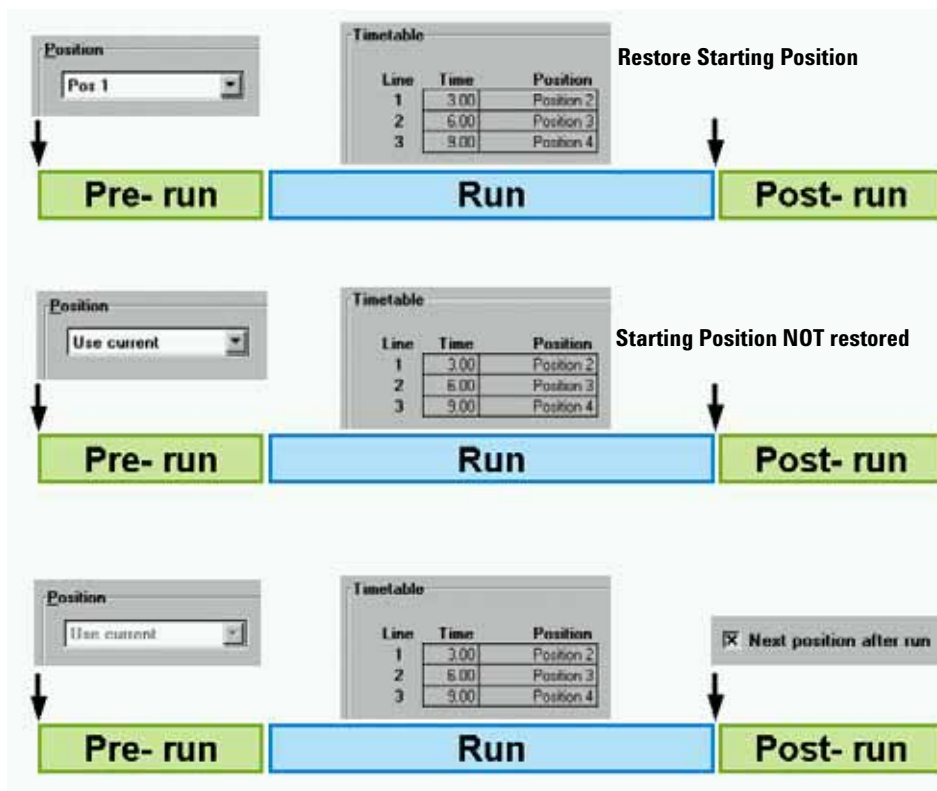

Figure 4 Valve Control

### Valve Name

Define the **Valve Name** that is used for the method report and the **Instrument actuals**. The **Valve Name** is limited to 20 characters.

## Position Descriptions

Define the **Position Description** that is used for the method report and the instrument actuals. The Position Description is limited to 19 characters.

**Table 6** Available valve positions

Valve Description	Product Number	# of Positions Descriptions
2 position / 10 port valve	G1157A / G1163A	2
2 position / 6 port valve	G1158A / G1158B / G1162A	2
6 position selection valve	G1159A	6
12 position / 13 port selection valve	G1160A	12

## Time Table

The **Time Table** can be used to edit and run a valve program during a sequence of sample runs. The Time Table contains 3 columns (**Line, Time and Position**). The Time Table is limited to 20 lines. The number of selection in the Position column depends on the valve that has been configured.

<b>Position X</b>	switches the valve to the selected position. The number of available positions for the Agilent 1200 Series valves is displayed in <a href="#">Table 6</a> .
<b>Next Position</b>	switches to the next available position. If the valve is on the highest position it will switch to position 1.
<b>Insert</b>	Inserts a line in the <b>Time Table</b> above the selected position.
<b>Append</b>	Appends a line at the end of the <b>Time Table</b> .
<b>Cut</b>	Cuts the selected line(s) out of the <b>Time Table</b> and saves it to the clipboard.
<b>Copy</b>	Copies the selected line(s) from the table to the clipboard.
<b>Paste</b>	Pastes line(s) from the Clipboard to the <b>Time Table</b> .

## Operating the Valve using Agilent ChemStation

**Next position after run**

If **Next position after run** is checked, the valve will switch to the next available position after the run is completed and remains there for the next run. For this selection the **Position** field is greyed out (see [Figure 4](#) on page 19).

**Display instrument actuals**

In order to display the current status of your Agilent 1200 Series valve choose **Instrument Actuals** from the **View** menu in the Agilent ChemStation to open the Valve Status dialog box ([Figure 5](#)).

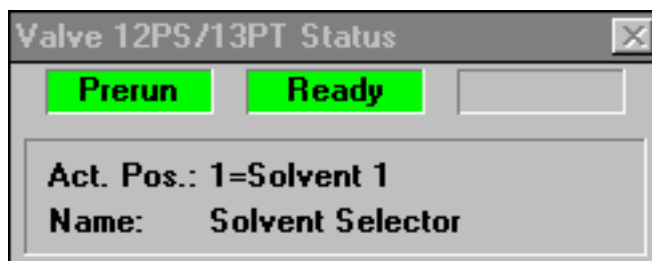

**Figure 5** Instrument Actuals

## Handheld Controller functions

With firmware revision B.03.11 or higher the following valve functions with the Agilent 1200 Series control module G1323B are available. Complete control of an Agilent 1200 Series valve during an LC analysis requires ChemStation Revision A.09.03 or higher.

### Switching the Valve

- 1 From the startup screen of the Agilent 1200 Series control module select **System (F5)**
- 2 Select **Control (F5)** and then **Valve** to open the screen that is displayed in [Figure 6](#). Use the arrow keys (up and down) to switch the valve to the next position.

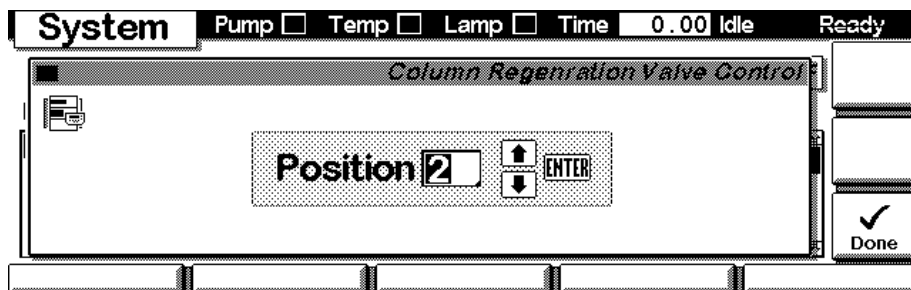

**Figure 6** Switching the Agilent 1200 Series valve

### Valve Synchronization

- 1 From the startup screen of the Agilent 1200 Series control module select **System (F5)**
- 2 Select **Tests (F3)** and **Valve** to open the Synchronization screen as displayed in [Figure 7](#).
- 3 Press **Synchronize (F7)** and select the position for the valve synchronization. Please also read the section "[Valve Synchronization](#)" on page 41.

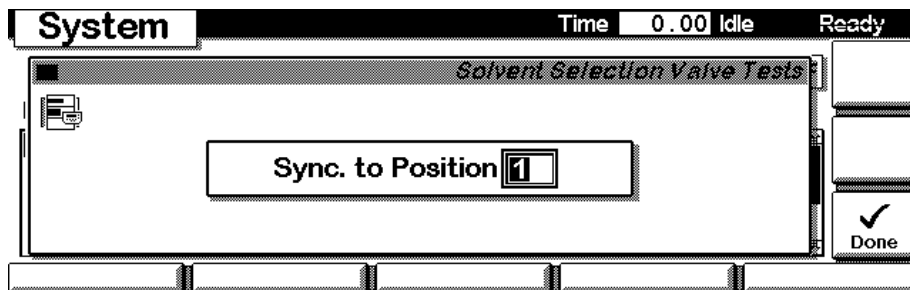

Figure 7 Valve Synchronization

### Setting the EMF limit and switch counter

- 1 From the startup screen of the Agilent 1200 Series control module select **System (F5)**
- 2 Select **Records (F4)** and scroll through the displayed module list and select the Agilent 1200 Series Valve.
- 3 Press **EMF (F1)** and then select **1 Setup Limits**.
- 4 In the upcoming dialog ([Figure 8](#)) edit the EMF limit. If this limiting number of switches has been reached, you will get an Early Maintenance Feedback signal on your Handheld controller and in the Graphical User Interface of the Agilent ChemStation Software. After you have done an maintenance action, press **Reset (F7)** to reset the switch counter. Also refer to the section "[Early Maintenance Feedback \(EMF\)](#)" on page 36.

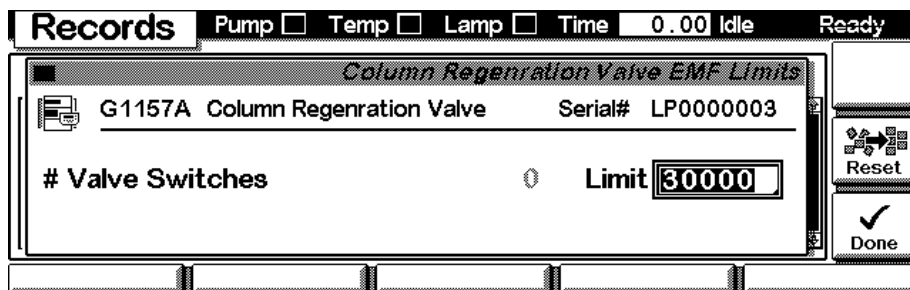

Figure 8 Early Maintenance Feedback (EMF) Screen

## Valve Control with the 1200 Series Instant Pilot

The 1200 Series Instant Pilot G4208A provides full control for all external switching valves. It allows to access valve maintenance and diagnostic functions, e.g. valve synchronization or Early Maintenance Feedback EMF. In addition the user can setup valve method parameters and a switching timetable.

### NOTE

The following instruction are based on the 12 position /13 port selection valve G1160A. Screens for other 1200 Series valve types are identical except for the valve name and the number of available positions.

### Setting up a Valve Method

Select **Method** on the Instant Pilot to set-up the following parameters (Figure 9):

<b>Position</b>	Default position for the selected method. The valve switches to this position after loading the method or after pressing Done.
<b>Analysis Start Position</b>	Defines the position of the valve at the start of the Analysis, i.e. before any pre-run task is executed. The following values can be selected: <ul style="list-style-type: none"> <li>• 1..n (absolute position)</li> <li>• +1..+n (relative position)</li> <li>• keep</li> </ul>
<b>Run Start Position</b>	Defines the position of the valve at the start of the Run (t=0, switch of the injection valve). The following values can be selected: <ul style="list-style-type: none"> <li>• 1..n (absolute position)</li> <li>• +1..+n (relative position)</li> <li>• keep</li> </ul>
<b>Run End Position</b>	Defines the position of the valve at the end of the Run (end of data acquisition). The following values can be selected: <ul style="list-style-type: none"> <li>• 1..n (absolute position)</li> <li>• +1..+n (relative position)</li> <li>• keep</li> </ul>

## Valve Control with the 1200 Series Instant Pilot

- Analysis End Position** Defines the position of the valve at the End of the Analysis, i.e. after all post-run activities have been completed. The following values can be selected:
- 1..n (absolute position)
  - +1..+n (relative position)
  - keep

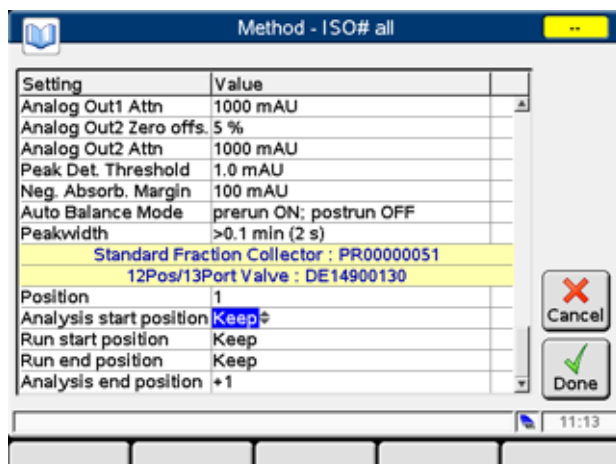

**Figure 9** Setting up method parameters for the 1200 Series valve

### Setting up a Valve timetable

Switching valve positions during the run allows advanced LC applications, e.g. sample enrichment to increase sensitivity of your method. If you select **Timetable** on the Instant Pilot, you can setup a sequence of timed valve events during the run (Figure 10):

- Time** Specifies the time for the valve switch during the run. 0.00 min. is the start of the run.
- Position** Switches the valve to the defined position. The following values can be selected:
- 1..n (absolute position)
  - keep

**Relative Position**

Switches the valve to a new position relative to the current one. The following values can be selected:

- Next
- Previous

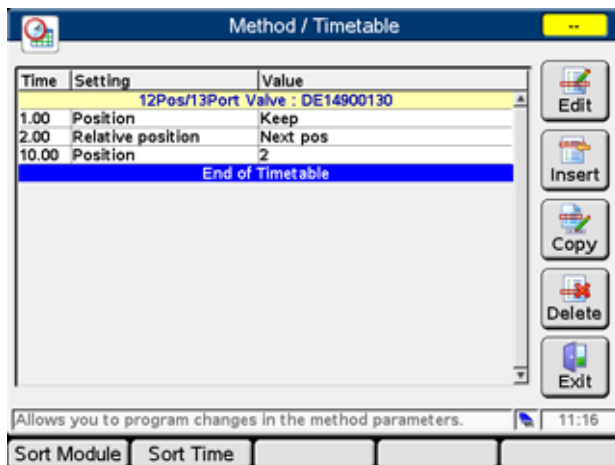

**Figure 10** Setting up a timetable for 1200 Series valves

**Maintenance functions**

Select **More > Maintenance**, then scroll to the valve to get access following the Maintenance functions.

**Set up Early Maintenance Feedback (EMF)** Specify the EMF limit and press **Done** in the Maintenance / EMF Setup screen (Figure 11). If this limiting number of switches has been reached, you will get an Early Maintenance Feedback signal on your Instant Pilot. Also refer to the section [Chapter 3](#), “Early Maintenance Feedback (EMF),” starting on page 36.

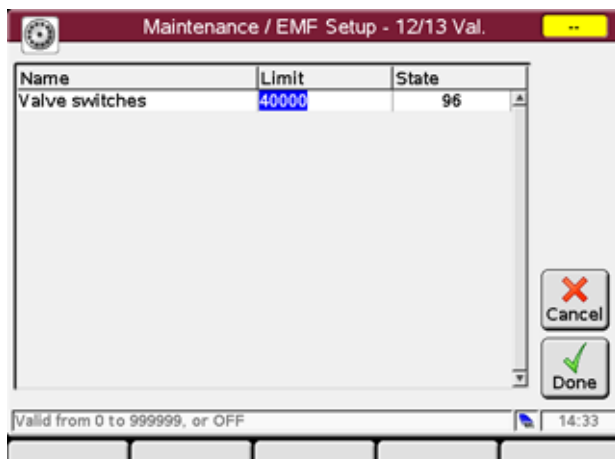

Figure 11 Setup EMF

**Valve Synchronization** If the valve failed to switch or if the current position of the valve is unknown, it might be necessary to synchronize the valve. Select the position for the valve synchronization, then press **Cont** (Figure 12).

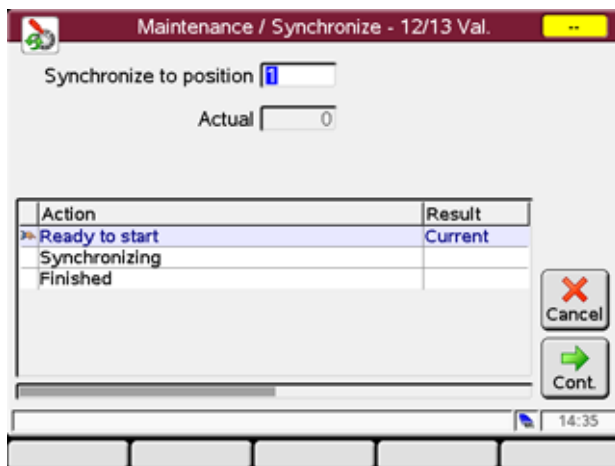
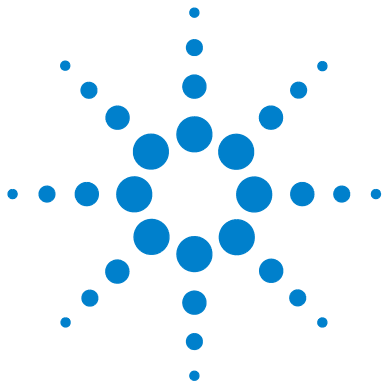

Figure 12 Valve Synchronization





### **3**

## **Maintenance, Repair, and Troubleshooting**

Status Indicators 30  
Maintenance and Repair 31  
System Errors and Troubleshooting 38



## Status Indicators

The instrument status indicator indicates one of four possible instrument conditions:

- When the status indicator is OFF, the instrument is in a prerun condition, and is ready to begin an analysis.
- A *green* status indicator indicates the instrument is performing an analysis (*run mode*).
- A *yellow* status indicator indicates a *not-ready* condition. The instrument is in a not-ready state when it is waiting for a specific condition to be reached or completed, or while a self-test procedure is running. The next programmed injection will be inhibited until the not-ready condition has been cleared.
- An *error* condition is indicated when the status indicator is *red*. An error condition indicates the instrument has detected an internal problem which affects correct operation of the instrument. Usually, an error condition requires attention (for example, leak, defective internal components). An error condition always interrupts the analysis and prevents the next run after the current run is finished.
- A *flashing red* status indicator indicates a severe error during the *startup* procedure of the module. Call your local service provider for assistance upon observing this error condition.

## Maintenance and Repair

The maintenance of the Agilent 1200 Series valves (G1157A, G1158A, G1159A, G1160A) includes the exchange of the stator face and the rotor seal. In addition it might be necessary to exchange the stator head, if the threads are worn out or if a fitting is broken and cannot be removed from the stator head.

In contrast to the valves for standard bore LC systems, the valve head assemblies of the Agilent 1200 Series micro valves (G1162A and G1163A) and the high pressure valve (G1158B) don't contain a stator face. Only the rotor seal needs to be exchanged during maintenance.

The valve head assemblies are displayed in [Figure 13](#) on page 32, [Figure 14](#) on page 33 and [Figure 15](#) on page 34. Part numbers of the rebuild kits, rotor seals and stator heads are listed in [Table 7](#) on page 35.

**CAUTION**

Always rinse the valve with water after using aqueous buffers or salt solutions to prevent crystal formation which may damage the valve.

---

## Replacing the stator face and the rotor seal for standard valves (G1157A, G1158A, G1159A, G1160A)

### Disassembling the valve head

- 1 Use the Hex Key to remove the Stator Screws (1) from the Stator Head (2).
- 2 Disassemble the Stator Head and Stator Face (5) from the Stator Ring (4). The Stator Face usually remains on the Stator Head.
- 3 Remove the three Stator Ring Screws (3) and take off the Stator Ring (4).
- 4 Remove the Rotor Seal(6) from the Valve Body(7). The Rotor Seal is mounted on three pins, and can be pulled off.

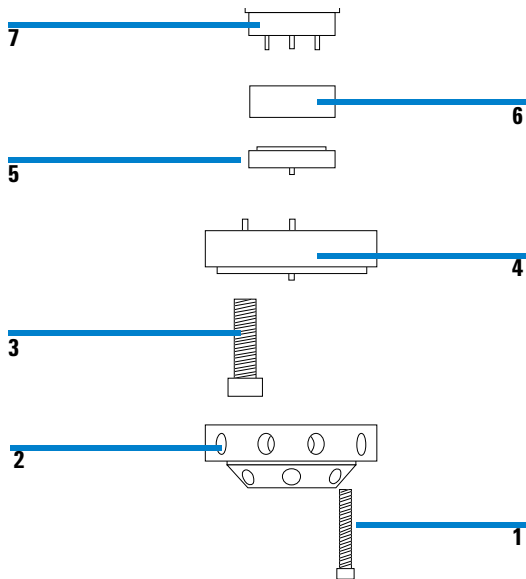

**Figure 13** Valve head assembly

### Reassembling the valve head

- 1 Mount the new Rotor Seal (6) with the slots facing the Stator Head (2). The three pins (8) on the Shaft Assembly fit into the matching holes(9) in the Rotor Seal only one way.

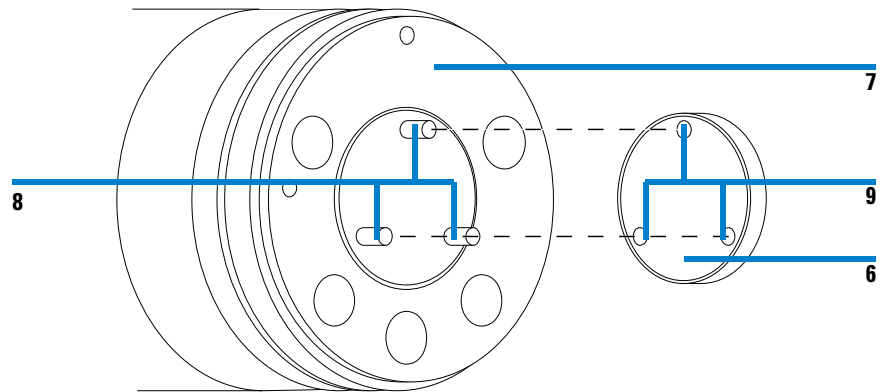

**Figure 14** Valve body (7) and Rotor seal (6)

- 2 Align the Stator Ring (4) that the two short pins on the ring enter the matching holes in the body (7).
- 3 Insert the three Stator Ring Screws (3). Turn each of the screws an equal amount until the they are finger-tight, then tighten them another half turn.
- 4 Mount the new Stator Face (5) onto the Stator Head (2). The pins on the Stator face must fit into the matching holes of the Stator Head.
- 5 Assemble the Stator Head (2) and Stator Face(5) that the pin in the Stator Ring enters the matching hole in the Stator Head.
- 6 Insert the Stator Screws (1). Turn each of the screws an equal amount until the they are finger-tight, then tighten them another half turn.

## Replacing the rotor seal for micro valves (G1162A and G1163A) and the high pressure valve (G1158B)

### Disassembling the valve head

- 1 Use the Hex Key to remove the Stator Screws (1) from the Stator Head (2).
- 2 Disassemble the Stator Head (2)
- 3 Remove the three Stator Ring Screws (3) and take off the Stator Ring (4).
- 4 Remove the Rotor Seal (5) from the Valve Body (6). The Rotor Seal is mounted on three pins.

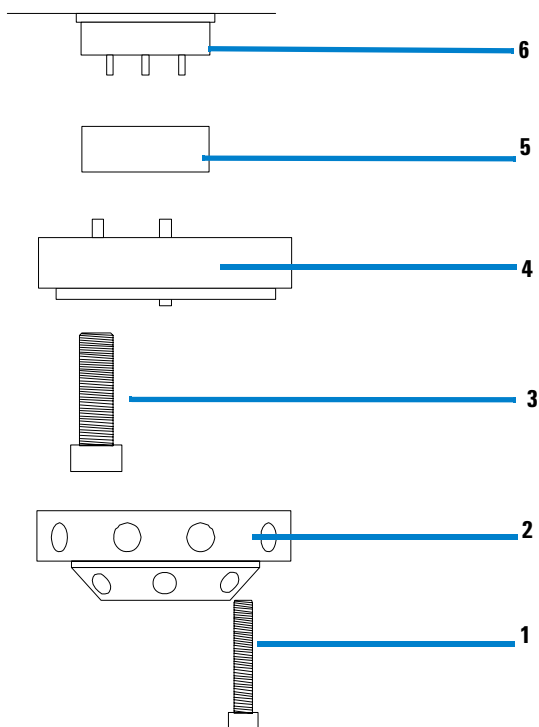

**Figure 15** micro valve head assembly

### Reassembling the valve head

- 1 Mount the new Rotor Seal (5) with the grooves facing the Stator Head (2). The three pins on the Shaft Assembly fit into the matching holes in the Rotor Seal only one way.
- 2 Mount the Stator Ring on the Shaft Assembly that the two pins fit to the matching holes on the Valve body.
- 3 Assemble the Stator Head (2) that the pin in the Stator Ring fits to the matching hole in the Stator Head.
- 4 Insert the Stator Screws (1). Turn each of the screws an equal amount until they are finger-tight, then tighten them another half turn.

**Table 7** Maintenance and repair parts for 1200 Series valves

Valve Type	Description	Rhebuild Kit*	Rotor Seal	Stator
G1157A	2 position/10 port valve	0101-1359	N/A	0101-1362
G1158A	2 position/6 port valve	0101-1358	0100-1855 (Vespel) 0100-1854 (Tefzel) 0100-2233 (PEEK)	0100-1850
G1158B	2 position/6 port valve (600 bar)	N/A	0101-1409 (PEEK blend)	0101-1417
G1159A	6 position selection valve	0101-1290	N/A	0101-1364
G1160A	12 position/13 port selection valve	0101-1288	N/A	0101-1365
G1162A	2 position/6 port micro valve	NA	0100-2087	0100-2089 (coated) 5023-0241 (uncoated)
G1163A	2 position/10 port micro valve	NA	0101-1361	0101-1363 (coated) 5023-0241 (uncoated)

\* Rhebuild Kit includes Rotor Seal, Stator Face, and tools.

## Early Maintenance Feedback (EMF)

Depending on the application the valve will perform many thousands of actuations without any visible signs of wear. In order to minimize downtime the Agilent ChemStation offers *Early Maintenance Feedback (EMF)* for the Agilent 1200 Series valves. EMF monitors the number of switches of the Agilent 1200 Series valves, and provides feedback when a user-settable limit is exceeded. The visual feedback in the graphical user interface provides an indication, that the exchange of the stator face and/or the rotor seal should be scheduled.

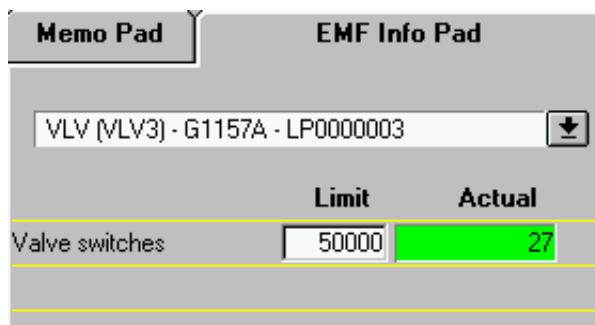

**Figure 16** Early Maintenance Feedback (EMF)

In the **Diagnostics** view you can define, after how many valve switches the stator face and/or the rotor seal should be replaced. The setting for the EMF limit depends on analytical conditions, e.g. use of buffer solutions. Hence the setting should be optimized over one or two maintenance cycles.

### Setting the EMF limit

- 1 Switch to the **Diagnostics** View of the ChemStation.
- 2 Click on the **EMF** icon. The **EMF Info Pad** (Figure 16) will appear on the right panel of the user interface.
- 3 Select a valve on the dropdown list of the **EMF Info Pad**.
- 4 Enter the EMF limit and click on **Send Changes**.

**Resetting the EMF counter**

- 1 Switch to the **Diagnostics** View of the ChemStation.
- 2 Select **Valve** from the **Maintenance** menu.
- 3 In the upcoming dialog box click on **Reset Counter** (see also [Figure 21](#) on page 41).

The procedure to reset the EMF counter with the Agilent 1200 Series control module is described on [page 23](#).

## System Errors and Troubleshooting

### System Errors

#### No line power

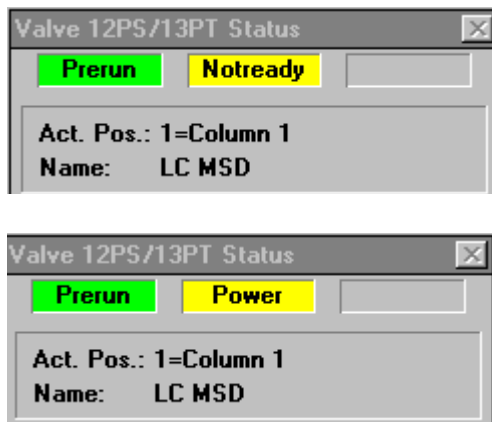

**Figure 17** Display of instrument actuals at a no line power state

**Error Cause** If the 24 volt DC line power is not available, the yellow **Notready** status is displayed in the instrument actuals. If you try to switch the valve, this status changes to **Power**.

#### Actions

- 1 Check power cable to external power supply or to another Agilent 1200 Series module
- 2 If the valve power is supplied by another Agilent 1200 Series module, check if this particular module is switched on.
- 3 Restart the ChemStation

### CAN failure

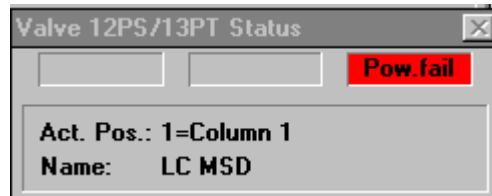

**Figure 18** CAN failure

**Error Cause** If the red **Pow. fail** status is visible the CAN communication is interrupted.

#### Actions

- 1 Check the CAN connection at the valve and at all other modules.
- 2 Check that the maximum number of 13 Agilent 1200 Series modules (including CAN slaves) is not exceeded.
- 3 Restart the ChemStation.

### Switch failure

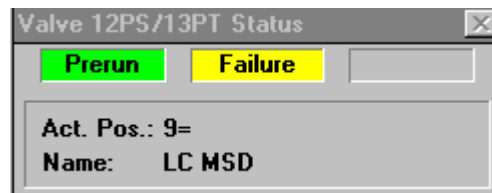

**Figure 19** Switch failure

**Error Cause** The yellow failure status indicates, that the valve didn't switch correctly

#### Actions

- 1 Synchronize the valve as described on [page 41](#)
- 2 Restart the ChemStation
- 3 Disconnect and replug the CAN cable

### Unknown Position

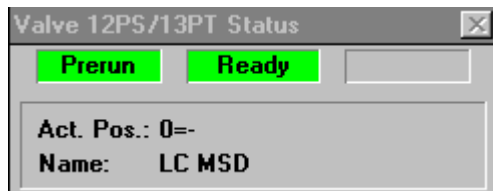

**Figure 20** Unknown Position

**Error Cause** An unknown position is indicated **Act. Pos.: 0=-**

#### Actions

- 1 Synchronize the valve as described on [page 41](#).
- 2 Restart the ChemStation.
- 3 Disconnect and replug the CAN cable.

## Valve Synchronization

If the valve failed to switch or if the current position of the valve is unknown, it might be necessary to synchronize the valve.

To synchronize the valve

Step	Note
1 Switch to the <b>Diagnostics</b> view.	
2 Select <b>Valve</b> from the <b>Maintenance</b> menu.	The valve should now display the <b>Current Position</b> as displayed in <a href="#">Figure 21</a> . If the current position is 0, it is unknown
3 To synchronize the valve, choose any position from the <b>Synchronize to position</b> dropdown list and click <b>OK</b> .	

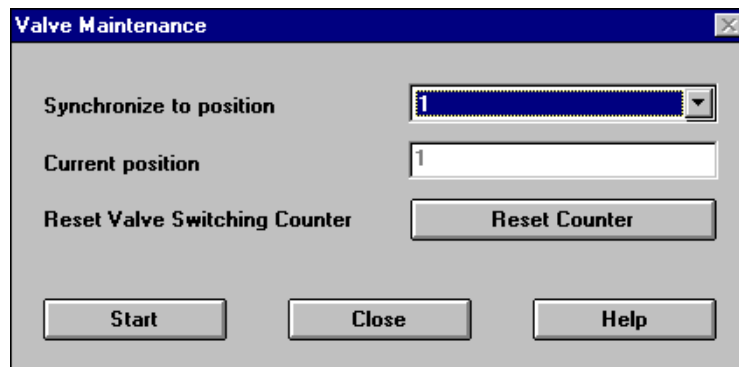

**Figure 21** Valve Synchronization



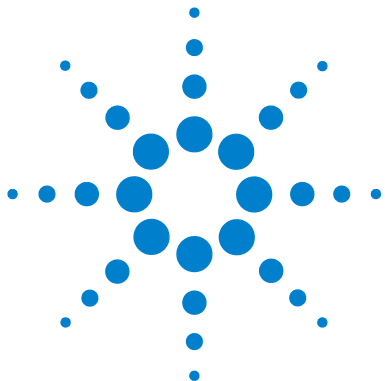

## 4 Valve Applications

Alternating Column Regeneration	44
Sample enrichment and Sample stripping	48
Automated Configuration Switch for the G1312B RRLC pump	52
Column Selection	54
Solvent Selection	56

In this chapter selected applications for the Agilent 1200 Series Valves will be described. This description will contain:

- short description
- flow diagrams
- part numbers of capillaries, fittings and capillary kits



## Alternating Column Regeneration

Alternating column regeneration is a convenient way to increase the sample throughput. The Agilent 1200 Series 2 position/ 10 port valve (G1157A) can be used in combination with the Agilent LC and LC/MS modules to increase the efficiency in laboratories running large amounts of samples.

Gradient elution is a common technique for separation of complex samples in liquid chromatography, which requires column regeneration before the subsequent run is started. Using alternating column regeneration valuable time for the analysis is saved. Core of the alternating column regeneration is the Agilent 1200 Series 2 position / 10 port valve, which allows simultaneous analysis on one column while a second identical column is flushed and equilibrated. The schematic setup is displayed in [Figure 22](#).

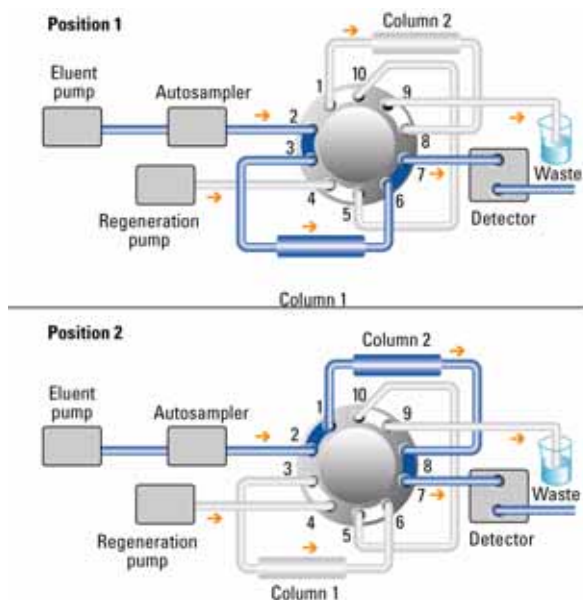

**Figure 22** Alternating Column Regeneration (schematic setup)

## Alternating Column Regeneration

If the valve is switched to position 1 the eluent pump delivers the mobile phase through the injection loop of the autosampler into port 2 of the Agilent 1200 Series Valve. The sample is separated on column 1 and analyzed by the detector. Simultaneously a second regeneration pump flushes and equilibrates column 2.

After the analysis of the sample is finished on column 1, column 2 is prepared for an immediate injection. The 2 position/ 10 port valve is switched and the sample can be injected and analyzed. While the analysis is running on column 2, column 1 is now regenerated and will be ready to use immediately after the sample run on column 2 is finished.

The advantage of this technique is visualized in [Figure 23](#), where the time of analysis with sequential column regeneration is compared to time of analysis using alternating column.

A detailed description how to setup alternating column regeneration with an Agilent 1200 Series LC system is provided in the application notes with the publication numbers 5988-7831EN and 5988-7895EN.

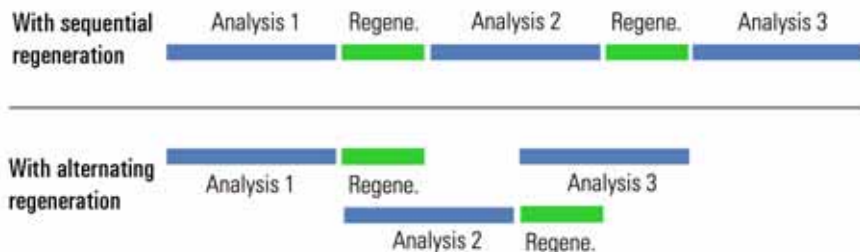

**Figure 23** Alternating column regeneration (time scheme)

We recommend to use the Agilent Technologies Capillary kits for Alternating Column Regeneration. These kits contain all capillaries, fittings and ferrules that are required for the setup displayed in [Figure 22](#) on page 44. Agilent Technologies offers one kit for analytical scale applications (flow rates < 10 ml/min), that contain the capillaries listed in [Table 8](#) on page 46 and fittings listed in [Table 9](#) on page 46. Another kit is suited for preparative scale applications (flow rates < 100 ml/min). Its capillaries are listed in [Table 10](#) on page 47 and its fitting are listed in [Table 11](#) on page 47.

### Capillary Kit (G1156-68711) for alternating column regeneration with G1157A (analytical scale)

**Table 8** Capillaries

From	To	ID/mm	Length/mm	part number
Injector/Autosampler	Valve (port 2)	0.17	500	G1328-87600
Valve (port 3)	Column 1	0.17	600	5021-1819
Column 1	Valve (port 6)	0.17	400	5065-9933
Valve (port 7)	Detector	0.17	600	5065-9933
Valve (port 8)	Column 2	0.17	400	5021-1819
Column 2	Valve (port 1)	0.17	600	5065-9933
Valve (port 5)	Valve (port 10)	0.17	105	5021-1816
Regeneration Pump	Valve (port 4)	0.25	800	5065-9930
Valve (port 9)	Waste	0.6 (PTFE)	2000	0890-1713

**Table 9** Fittings, screws, and ferrules

Description	Qty	part number
1/16" fittings and ferrules 10/pk	1	5062-2418
fingertight fitting (long)	1	5062-8541 (10/pk)
fitting screw (long)	10	5065-4454 (10/pk)
fitting screw (extra long)	4	5065-9967 (10/pk)
front ferrule 10/pk	1	5180-4108
back ferrule 10/pk	1	5180-4114
ZDV fitting	1	0100-0900
0.18 ID PEEK tubing (1.5 m)	1	0890-1763
Plastic tubing cutter	1	8710-1930

### Capillary Kit (G1156-68713) for alternating column regeneration with G1157A (preparative scale)

**Table 10** Capillaries

From	To	ID/mm	Length/mm	part number
Injector/Autosampler	Valve (port 2)	0.5	600	G2260-87300
Valve (port 3)	Column 1	0.5	600	G2260-87301
Column 1	Valve (port 6)	0.5	400	G2260-87300
Valve (port 7)	Detector	0.5	600	G2260-87300
Valve (port 8)	Column 2	0.5	400	G2260-87301
Column 2	Valve (port 1)	0.5	600	G2260-87300
Valve (port 5)	Valve (port 10)	0.5	105	5065-9927
Regeneration Pump	Valve (port 4)	0.5	800	5065-9926
Valve (port 9)	Waste	0.6 (PTFE)	2000	0890-1713

**Table 11** Fittings, screws, and ferrules

Description	Qty	part number
1/16" fittings and ferrules 10/pk	1	5062-2418
fingertight fitting (long)	1	5062-8541 (10/pk)
fitting screw (long)	10	5065-4454 (10/pk)
fitting screw (extra long)	4	5065-9967 (10/pk)
front ferrule 10/pk	1	5180-4108
back ferrule 10/pk	1	5180-4114
Union Prep	1	5022-2133
0.5 ID PEEK tubing (1.5 m)	1	0890-1761
Plastic tubing cutter	1	8710-1930

## Sample enrichment and Sample stripping

Sample enrichment and sample stripping methods can be used to separate samples from complex matrices, such as biological fluids, food extracts or wastewater. This might be necessary to avoid interference of the matrix during separation and detection or even damage of the column. You can use the Agilent 1200 Series 2 position/ 6 port valve (G1158A) to automate these techniques for LC and LC/MS analysis.

### Sample enrichment

Sample enrichment is used to increase the sensitivity and to remove the sample matrix. The technique is displayed in [Figure 24](#) on page 48. This technique allows the injection of large volumes onto the precolumn, where the sample matrix is separated from the analytes in order to increase sensitivity.

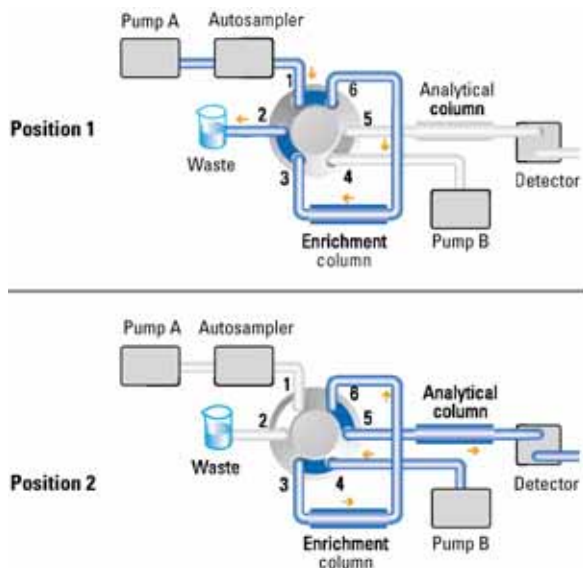

**Figure 24** Sample enrichment (schematic setup)

## Sample enrichment and Sample stripping

For the sample enrichment phase the valve is switched to position 1. The eluent Pump A transfers the injected sample onto the enrichment column. The sample is retained and enriched on this column, whereas the sample matrix is flushed into the waste. At the same time the second eluent pump B is equilibrating the analytical column.

After the valve is switched to position 2 pump B is backflushing the sample on the analytical column for separation and subsequent detection by LC/MS or optical detectors.

Agilent Technologies offers capillary kit for sample enrichment and sample stripping. The content is listed in [Table 12](#) on page 50 and [Table 13](#) on page 51.

## Sample stripping

Sample stripping is another method to remove complex sample matrices. In difference to sample enrichment the matrix is trapped on the pre-column while the analytes pass through onto the analytical column.

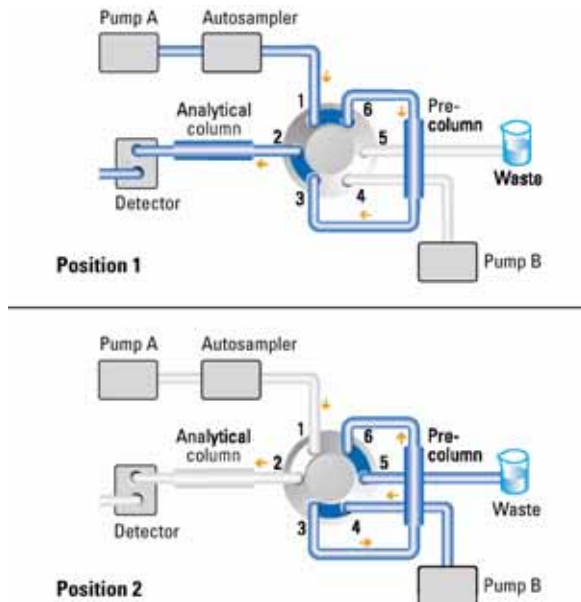

**Figure 25** Sample stripping (schematic setup)

Figure 25 on page 49 illustrates how the Agilent 1200 Series 2 position/ 6 port valve can be used for sample stripping. In valve position 1 Pump A transfers the complete sample matrix onto the pre-column 1, where the matrix is trapped while the analytes are eluted and flushed to column 2 for analysis. Then the valve switches to position 2. Now pump B backflushes the matrix to the waste, while pump A continues to deliver solvent to the analytical column, where the analytes are separated and analyzed.

Agilent Technologies offers a capillary kit for sample enrichment and stripping as displayed in Table 12 on page 50 and Table 13 on page 51.

### Capillary kit for sample enrichment/stripping (G1156-68714) with G1158A (analytical scale)

**Table 12** Capillaries

From	To	ID/mm	Length/mm	part number
<b>Sample Enrichment</b>				
Injector/Autosampler	Valve (port 1)	0.17	500	G1328-87600
Valve (port 2)	Waste	0.6 (PTFE)	2000	0890-1713
Valve (port 3)	Enrichment Column	0.17	400	5021-1819
Enrichment Column	Valve (port 6)	0.17	600	5065-9933
Pump B	Valve (port 4)	0.25	800	5065-9930
Valve (port 5)	Analytical Column	0.17	400	5021-1819
Analytical Column	Detector	0.17	600	5065-9933
<b>Stripping</b>				
Injector/Autosampler	Valve (port 1)	0.17	500	G1328-87600
Valve (port 2)	Analytical Column	0.17	400	5021-1819
Analytical Column	Detector	0.17	600	5065-9933
Valve (port 3)	Pre-Column	0.17	400	5021-1819
Pre-Column	Valve (port 6)	0.17	600	5065-9933
Pump B	Valve (port 4)	0.25	800	5065-9930
Valve (port 5)	Waste	0.6 (PTFE)	2000	0890-1713

## Sample enrichment and Sample stripping

**Table 13** Fittings, screws, and ferrules

<b>Description</b>	<b>Qty</b>	<b>part number</b>
1/16" fittings and ferrules 10/pk	1	5062-2418
fingertight fitting (long)	1	5062-8541 (10/pk)
fitting screw (long)	5	5065-4454 (10/pk)
front ferrule 10/pk	1	5180-4108
back ferrule 10/pk	1	5180-4114
ZDV fitting	1	0100-0900
0.18 ID PEEK tubing (1.5 m)	1	0890-1763
Plastic tubing cutter	1	8710-1930

## Automated Configuration Switch for the G1312B RRLC pump

The Agilent 1200 Series binary pump SL G1312B for Rapid Resolution Liquid Chromatography can be operated in several configurations depending on the selected column and detection method. The 2 position / 6 port valve (600 bar) G1158B provides a convenient way to switch automatically between these pump configurations. The required accessories are included in the Pump Configuration Kit G1312-68712. The capillary connections are described in [Table 14](#) and [Table 15](#). For selecting the right configuration please refer to the technical documentation of the binary pump SL or the 1200 Series RRLC system.

### CAUTION

The Pump Configuration Kit (G1312-68726) includes a new plastic cover for the 1200 Series binary pump SL. Ensure that the rail assembly is on the left side facing the pump's front panel.

### Pump Configuration Kit for RRLC (G1312-68726)

**Table 14** Capillary connections for automated configuration switch with one mixer.

From	To	ID/mm	Length/mm	part number
Pump Pressure Sensor (2)	Valve (port 6)	0.17	230	5067-1570
Pump Damper (remove B)	Valve (port 1)	0.17	320	5067-1571
Valve (port 5)	Pump Purge Valve (A)	0.17	150	5067-1572
Pump Std. Mixer (400 µl)	Valve (Port 4)	0.17	280	5021-1818
Plastic Cover with mounting rail for G1158B				5067-1567
Plug Fittings for Port 2 and 3.				0100-1259

## Automated Configuration Switch for the G1312B RRLC pump

**Table 15** Capillary connections for automated configuration switch with standard mixer and short mixer .

<b>From</b>	<b>To</b>	<b>ID/mm</b>	<b>Length/mm</b>	<b>part number</b>
Pump Pressure Sensor (2)	Valve (port 6)	0.17	230	5067-1570
Pump Damper (remove B)	Valve (port 1)	0.17	320	5067-1571
Valve (port 3)	Pump Purge Valve (A)	0.17	150	5067-1572
Pump Std. Mixer (400µl)	Valve (Port 2)	0.17	280	5021-1818
Pump Short Mixer (200 µl)	Valve (Port 5)	0.17	90	G1316-87300
Pump Short Mixer (200 µl)	Valve (Port 4)	0.17	90	G1316-87300
Plastic Cover with mounting rail for G1158B				5067-1567

## Column Selection

With the Agilent 1200 Series 6 position selection valve (G1159A) and the capillary kit for Column Selection (Table 16 and Table 17 on page 55) you can set up your Agilent 1200 Series LC or LC/MS system for use with up to 6 columns as displayed in Figure 26. Or you can use the system with 5 columns and one flow path for flow injection analysis or for flushing the system. This setup allows you to switch between these columns for faster method development or method validation. The multi-column setup might also be used, if several operators are sharing the LC or LC/MS system.

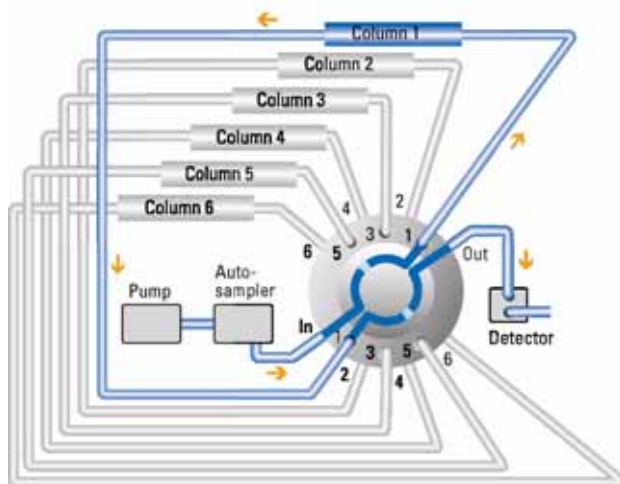

**Figure 26** Column selection (schematic setup)

**Capillary Kit (G1156-68712) for column selection with G1159A (analytical scale)****Table 16** Capillaries

<b>From</b>	<b>To</b>	<b>Qty.</b>	<b>ID/mm</b>	<b>Length/mm</b>	<b>part number</b>
Injector/Autosampler	Valve (IN)	1	0.17	500	G1328-87600
Valve (X)	Column X	6	0.17	400	5021-1819
Column X	Valve (X')	6	0.17	400	5021-1819
Valve (OUT)	Detector	1	0.17	600	G1328-87600

**Table 17** Fittings, screws, and ferrules

<b>Description</b>	<b>Qty</b>	<b>part number</b>
1/16" fittings and ferrules 10/pk	2	5062-2418
fitting screw (long)	15	5065-4454 (10/pk)
front ferrule 10/pk	1	5180-4108
back ferrule 10/pk	1	5180-4114
ZDV fitting	1	0100-0900
0.18 ID PEEK tubing (1.5 m)	1	0890-1763
Plastic tubing cutter	1	8710-1930

## Solvent Selection

The Agilent 1200 Series 12 position / 13 port valve can be used for solvent selection (flow rate < 10 ml/min) as illustrated in [Figure 27](#). It offers automated access to 12 different eluents.

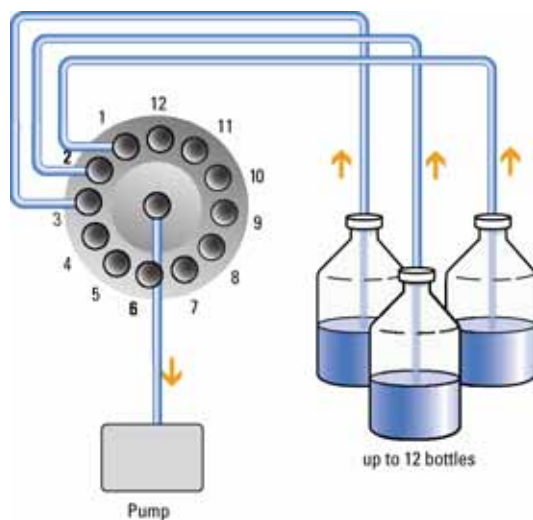

**Figure 27** Solvent selection (schematic setup)

**Tubing Kit (G1160-68706) for solvent selection (4 solvents) with G1160A, degasser and isocratic pump (flow rate < 10 ml/min)**

**Table 18 Tubing**

From	To	Qty.	ID/mm	Length/mm	part number
Solvent Bottle	Degasser	4	1.5	1000	G1311-60003
Degasser	Valve (pos.1-12)	4	1.5	600	G1160-67300
Valve (OUT)	Pump Inlet	1	1.5	600	G1160-67300

**Table 19 Finger-tight fittings**

Description	Qty	part number
Adapter, PEEK int. 1/4-28 to ext.10-32	5	0100-2298



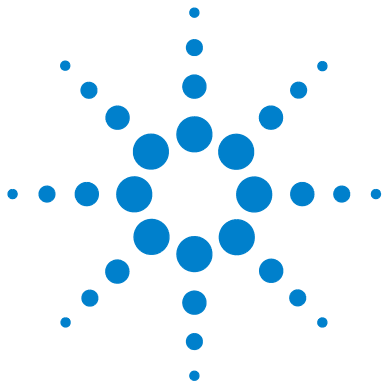

## 5 Parts

General Parts [60](#)

Capillaries and Fittings for analytical and preparative flow rates [62](#)

Capillaries and Fittings for micro valves [64](#)

In this chapter you will find part numbers and part descriptions for maintenance and repair.



## General Parts

**Table 20** General parts

<b>Description</b>	<b>part number</b>
• CAN cable, 1m long	5181-1519
• DC-Can cable	5181-1533
• External Power Supply	0950-4422
• Rail assembly for Column Organizer	5065-4450

**Table 21** Replacement valve assemblies

<b>Description</b>	<b>part number</b>
• 2 position/10 port valve	G1157-60011
• 2 position/6 port valve	G1158-60011
• 2 position/6 port valve (600 bar)	G1158-60021
• 6 position selection valve	G1159-60011
• 12 position/13 port selection valve	G1160-60011
• 2 position/6 port micro valve	G1162-60011
• 2 position/10 port micro valve	G1163-60011

**Table 22** Maintenance and repair parts for 1200 Series valves

Valve Type	Description	Rhebuild Kit*	Rotor Seal	Stator
G1157A	2 position/10 port valve	0101-1359	N/A	0101-1362
G1158A	2 position/6 port valve	0101-1358	0100-1855 (Vespel) 0100-1854 (Tefzel) 0100-2233 (PEEK)	0100-1850
G1158B	2 position/6 port valve (600 bar)	N/A	0101-1409 (PEEK blend)	0101-1417
G1159A	6 position selection valve	0101-1290	N/A	0101-1364
G1160A	12 position/13 port selection valve	0101-1288	N/A	0101-1365
G1162A	2 position/6 port micro valve	NA	0100-2087	0100-2089 (coated) 5023-0241 (uncoated)
G1163A	2 position/10 port micro valve	NA	0101-1361	0101-1363 (coated) 5023-0241 (uncoated)

\* Rhebuild Kit includes Rotor Seal, Stator Face, and tools.

## Capillaries and Fittings for analytical and preparative flow rates

**Table 23** Capillary and tubing kits

Description	part number
• Capillary kit: alternating column regeneration (analytical) for valve G1157A (for details see <a href="#">Table 8</a> and <a href="#">Table 9</a> on page 46)	G1156-68711
• Capillary kit alternating column regeneration (preparative) for valve G1157A (for details see <a href="#">Table 10</a> and <a href="#">Table 11</a> on page 47)	G1156-68713
• Capillary kit: alternating Sample enrichment/stripping (analytical) for valve G1158A (for details see <a href="#">Table 12</a> and <a href="#">Table 13</a> on page 51)	G1156-68714
• Capillary kit: column selection (analytical) for 6 columns with valve G1159A (for details see <a href="#">Table 16</a> and <a href="#">Table 17</a> on page 55)	G1156-68712
• Tubing kit: solvent selection for 4 solvents (< 10 ml/min) for valve G1160A (for details see <a href="#">Table 18</a> and <a href="#">Table 19</a> on page 57)	G1156-68706
• Pump Configuration Kit for binary pump SL with G1158B (for details see <a href="#">Table 14</a> and <a href="#">Table 15</a> on page 53)	G1312-68726

**Table 24** Part Numbers for flexible SST capillaries without fittings (volume in parentheses)

length in mm	0.12 mm ID	0.17 mm ID	0.25 mm ID	0.50 mm ID
105	5021-1820 (1.2µl)	5021-1816 (2.4µl)		5065-9927 (20.6µl)
150	5021-1821 (1.7µl)	5021-1817 (3.4µl)		5022-6509 (29.5µl)
200		5065-9931 (4.6µl)		
280	5021-1822 (3.2µl)	5021-1818 (6.4µl)	5062-6508 (13.8µl)	5022-6510 (55.0µl)
400	5021-1823 (4.5µl)	5021-1819 (9.1µl)		G2260-87301 (78.5µl)
500		G1328-87600 (11.4µl)		
600		5065-9933 (13.6µl)		G2260-87300 (117.8µl)
700		5065-9932 (15.9µl)		

**Table 24** Part Numbers for flexible SST capillaries without fittings (volume in parentheses)

length in mm	0.12 mm ID	0.17 mm ID	0.25 mm ID	0.50 mm ID
800			5065-9930 (39.3 $\mu$ l)	5065-9926 (157 $\mu$ l)





## Capillaries and Fittings for micro valves

For the operation of the Agilent 1200 Series micro valves we recommend the following fittings and PEEK coated fused silica capillaries as listed in [Table 25](#), [Table 26](#) and [Table 27](#).

**Table 25** Fittings and Ferrules for micro valves

Fitting Type	Description	Units of measure	Part number
A	1/16" SST fitting, front and back ferrule	10/pk	5062-2418
B	1/16" SST fitting male, wrench size 4	10/pk	5063-6593
B	1/32" SST ferrule and lock ring	10/pk	5065-4423
C	M4 PEEK fitting	6 fittings/2 plug	5065-4410
D	Double winged nuts and 1/32" ferrules	10/pk	5065-4422

**Table 26** Fitting Types

Fittings and ferrules	Fitting type
	A
	B
	C
	D

**Table 27** PEEK coated fused silica capillaries for micro valves

i.D./ $\mu\text{m}$	Length/mm	Volume/ $\mu\text{l}$	Fitting type*	Part number
100	150	1.178	B/C	G1375-87317
100	200	1.570	B/C	G1375-87312
100	220	1.728	B/B	G1375-87305
100	550	4.320	B/C	G1375-87306
100	1100	8.639	B/D	G1375-87315
100	1100	8.639	B/B	G1375-87303
75	400	1.767	D/E	G1375-87308
75	500	3.209	C/D	G1375-87311
50	150	0.295	B/C	G1375-87300
50	200	0.392	B/C	G1375-87302
50	220	0.432	B/B	G1375-87301
50	280	0.550	C/D	G1375-87309
50	500	0.982	C/D	G1375-87304
50	550	1.080	B/C	G1375-87310
25	100	0.049	C/D	G1375-87320
25	220	0.108	D/D	G1375-87321
25	350	0.172	C/D	G1375-87322
25	550	0.270	C/D	G1375-87323
25	700	0.344	C/D	G1375-87324

\* see [Table 26](#) on page 64



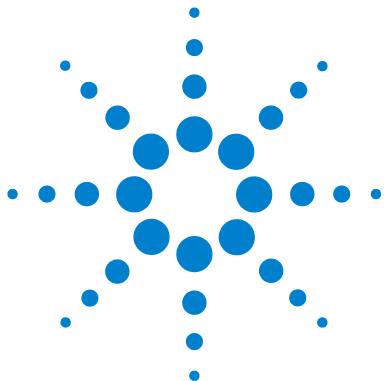

## 6 Specifications

G1157A Agilent 1200 Series 2 position / 10 port valve	68
G1158A Agilent 1200 Series 2 position / 6 port valve	68
G1159A Agilent 1200 Series 6 position selection valve	69
G1158B Agilent 1200 Series 2 position / 6 port valve (600 bar)	68
G1160A Agilent 1200 Series 12 position/ 13 port selection valve	69
G1162A Agilent 1200 Series 2 position/ 6 port micro valve	69
G1163A Agilent 1200 Series 2 position/ 10 port micro valve	70

In this chapter you will find the specifications of the Agilent 1200 Series valves.



**Table 28** G1157A Agilent 1200 Series 2 position / 10 port valve

Liquid contacts:	Stainless Steel and PEEK
Port size:	Accepts 10-32 male threaded fittings
Flow passage diameters:	Stator and stator face assembly 0.6 mm (0.024"), rotor seal 0.6 mm (0.024")
Volume in flow passage:	Stator (includes stator face seal) 2.1 µl/hole, rotor seal 0.7 µl/groove
Maximum pressure:	41 MPa (408 bar, 6000 psi)
Recommended flow range:	0.2 - 100 ml/min

**Table 29** G1158A Agilent 1200 Series 2 position / 6 port valve

Liquid contacts:	Stainless steel, PEEK, and alumina ceramic
Port size:	Accepts 10-32 male threaded fittings
Flow passage diameters:	Stator and stator face assembly 0.4 mm (0.015"), rotor seal 0.5 mm (0.018")
Volume in flow passage:	Stator (includes stator face seal) 0.7 µl/hole, rotor seal 0.3 µl/groove
Maximum pressure:	41 MPa (408 bar, 6000 psi)
Recommended flow range:	0.2 - 100 ml/min

**Table 30** G1158B Agilent 1200 Series 2 position / 6 port valve (600 bar)

Liquid contacts:	UltraLife coated stainless steel (stator) and UltraLife PEEK-Blend (rotor)
Port size:	Accepts 10-32 male threaded fittings
Flow passage diameters:	Stator 0.4 mm (0.015"), rotor seal 0.3 mm (0.012")
Volume in flow passage:	Stator 0.2 µl/hole in stator, rotor seal 0.1 µl/groove (0.5 µl port to port)
Maximum pressure:	60 Mpa (600 bar, 9000 psi)
Recommended flow range:	0.1 - 5 ml/min

**Table 31** G1159A Agilent 1200 Series 6 position selection valve

Liquid contacts:	Stainless steel and PEEK
Port size:	Accepts 10-32 male threaded fittings
Flow passage diameters:	Stator 0.6 mm (0.024"), stator face assembly and rotor seal 0.4 mm (0.015")
Volume in flow passage	Angled ports 1, 2, 5 (15.6 µl) Radial ports 2, 4, 6 (18,8 µl)
Maximum pressure:	35 MPa (345 bar, 5000 psi)
Recommended flow range:	0.3 - 40 ml/min*

\* The G1159A Agilent 1200 Series 6 positions selection valve can be used at flow rates up to 100 ml/min, but without valve switching. In most cases e.g. column selection the valve switches during the postrun or prerun, when the flow can be reduced.

**Table 32** G1160A Agilent 1200 Series 12 position/ 13 port selection valve

Liquid contacts:	Stainless steel and PEEK
Port size:	Accepts 10-32 male threaded fittings
Flow passage diameters:	1.0 mm (0.040")
Volume in flow passage:	Stator (includes stator face seal) 6.4 µl/hole, rotor seal 4.0 µl/groove
Maximum pressure:	21 MPa (207 bar, 3000 psi)
Recommended flow range:	0.2 - 100 ml/min (at high pressures, behind the pump) 0.2 - 10 ml/min (at low pressures, in front of the pump)

**Table 33** G1162A Agilent 1200 Series 2 position/ 6 port micro valve

Liquid contacts:	DuraLife processed stainless steel (stator) and vespel (rotor seal)
Port size:	Accepts M4 male threaded fittings
Flow passage diameters:	0.20 mm (0.008")

**Table 33** G1162A Agilent 1200 Series 2 position/ 6 port micro valve (continued)

Volume in flow passages:	70 nl port to port
Maximum pressure:	41 MPa (408 bar, 6000 psi)
Recommended flow range:	0.1 - 100 $\mu$ l/min

**Table 34** G1163A Agilent 1200 Series 2 position/ 10 port micro valve

Liquid contacts:	DuraLife processed stainless steel (stator) and vespel (rotor seal)
Port size:	Accepts M4 male threaded fittings
Flow passage diameters:	0.20 mm (0.008")
Volume in flow passages:	Stator (20° ports) 27.2 nl, (45° ports) 30.5 nl, rotor seal 25.0 nl/groove
Maximum pressure:	41 MPa (408 bar, 6000 psi)
Recommended flow range:	0.1 - 100 $\mu$ l/min

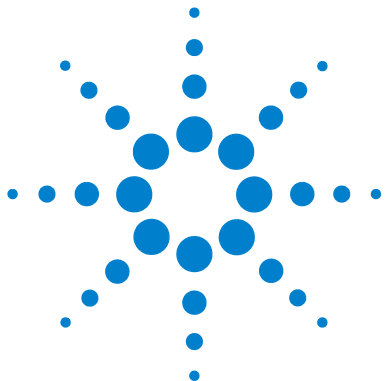

## 7 Safety Information

General Safety Information	72
Lithium Batteries Information	75
Radio Interference	76
Sound Emission	77
Solvent Information	78
Agilent Technologies on Internet	79S



## General Safety Information

The following general safety precautions must be observed during all phases of operation, service, and repair of this instrument. Failure to comply with these precautions or with specific warnings elsewhere in this manual violates safety standards of design, manufacture, and intended use of the instrument. Agilent Technologies assumes no liability for the customer's failure to comply with these requirements.

### General

This is a Safety Class I instrument (provided with terminal for protective earthing) and has been manufactured and tested according to international safety standards.

### Operation

Before applying power, comply with the installation section. Additionally the following must be observed.

Do not remove instrument covers when operating. Before the instrument is switched on, all protective earth terminals, extension cords, auto-transformers, and devices connected to it must be connected to a protective earth via a ground socket. Any interruption of the protective earth grounding will cause a potential shock hazard that could result in serious personal injury. Whenever it is likely that the protection has been impaired, the instrument must be made inoperative and be secured against any intended operation.

Make sure that only fuses with the required rated current and of the specified type (normal blow, time delay, and so on) are used for replacement. The use of repaired fuses and the short-circuiting of fuseholders must be avoided.

Some adjustments described in the manual, are made with power supplied to the instrument, and protective covers removed. Energy available at many points may, if contacted, result in personal injury.

Any adjustment, maintenance, and repair of the opened instrument under voltage should be avoided as much as possible. When inevitable, this should be carried out by a skilled person who is aware of the hazard involved. Do not

attempt internal service or adjustment unless another person, capable of rendering first aid and resuscitation, is present. Do not replace components with power cable connected.

Do not operate the instrument in the presence of flammable gases or fumes. Operation of any electrical instrument in such an environment constitutes a definite safety hazard.



Do not install substitute parts or make any unauthorized modification to the instrument.

Capacitors inside the instrument may still be charged, even though the instrument has been disconnected from its source of supply. Dangerous voltages, capable of causing serious personal injury, are present in this instrument. Use extreme caution when handling, testing and adjusting.

## Safety Symbols

Table 35 shows safety symbols used on the instrument and in the manuals.

**Table 35** Safety Symbols

Symbol	Description
	The apparatus is marked with this symbol when the user should refer to the instruction manual in order to protect the apparatus against damage.
	Indicates dangerous voltages.
	Indicates a protected ground terminal.

### **WARNING**

**A warning alerts you to situations that could cause physical injury or damage to the equipment. Do not proceed beyond a warning until you have fully understood and met the indicated conditions.**

### **CAUTION**

**A caution alerts you to situations that could cause a possible loss of data. Do not proceed beyond a caution until you have fully understood and met the indicated conditions.**

## Lithium Batteries Information

### WARNING

Danger of explosion if battery is incorrectly replaced. Replace only with the same or equivalent type recommended by the equipment manufacturer. Lithium batteries may not be disposed-off into the domestic waste.

Transportation of discharged Lithium batteries through carriers regulated by IATA/ICAO, ADR, RID, IMDG is not allowed. Discharged Lithium batteries shall be disposed off locally according to national waste disposal regulations for batteries.

---

### WARNING

Lithiumbatteri - Eksplosionsfare ved fejlagtig håndtering. Udskiftning må kun ske med batteri af samme fabrikat og type. Lever det brugte batteri tilbage til leverandoren.

---

### WARNING

Lithiumbatteri - Eksplosionsfare. Ved udskiftning benyttes kun batteri som anbefalt av apparatfabrikanten. Brukt batteri returneres apparatleverandoren.

---

### NOTE

Bij dit apparaat zijn batterijen geleverd. Wanneer deze leeg zijn, moet u ze niet weggooien maar inleveren als KCA.



## Radio Interference

Never use cables other than the ones supplied by Agilent Technologies to ensure proper functionality and compliance with safety or EMC regulations.

### **Test and Measurement**

If test and measurement equipment is operated with equipment unshielded cables and/or used for measurements on open set-ups, the user has to assure that under operating conditions the radio interference limits are still met within the premises.

## Sound Emission

### Manufacturer's Declaration

This statement is provided to comply with the requirements of the German Sound Emission Directive of 18 January 1991.

This product has a sound pressure emission (at the operator position) < 70 dB.

- Sound Pressure  $L_p < 70$  dB (A)
- At Operator Position
- Normal Operation
- According to ISO 7779:1988/EN 27779/1991 (Type Test)

## Solvent Information

Observe the following recommendations on the use of solvents.

### Solvents

Brown glass ware can avoid growth of algae.

Always filter solvents, small particles can permanently block the capillaries. Avoid the use of the following steel-corrosive solvents:

- Solutions of alkali halides and their respective acids (for example, lithium iodide, potassium chloride, and so on).
- High concentrations of inorganic acids like nitric acid, sulfuric acid especially at higher temperatures (replace, if your chromatography method allows, by phosphoric acid or phosphate buffer which are less corrosive against stainless steel).
- Halogenated solvents or mixtures which form radicals and/or acids, for example:

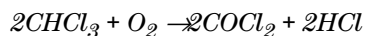

This reaction, in which stainless steel probably acts as a catalyst, occurs quickly with dried chloroform if the drying process removes the stabilizing alcohol.

- Chromatographic grade ethers, which can contain peroxides (for example, THF, dioxane, di-isopropylether) such ethers should be filtered through dry aluminium oxide which adsorbs the peroxides.
- Solutions of organic acids (acetic acid, formic acid, and so on) in organic solvents. For example, a 1-% solution of acetic acid in methanol will attack steel.
- Solutions containing strong complexing agents (for example, EDTA, ethylene diamine tetra-acetic acid).
- Mixtures of carbon tetrachloride with 2-propanol or THF.

## Agilent Technologies on Internet

For the latest information on products and services visit our worldwide web site on the Internet at:

<http://www.agilent.com>

Select **“Products”** - **“Chemical Analysis”**

It will provide also the latest firmware of the Agilent 1200 Series modules for download.

**7 Safety Information**  
Agilent Technologies on Internet

# Index

## A

accessory kit, 9, 10  
Agilent ChemStation, 15, 18  
Agilent on internet, 79  
alternating column regeneration, 44  
    analytical scale, 46  
    preparative scale, 47  
analytical scale  
    alternating column regeneration, 46  
    column selection, 55  
    sample enrichment, 50

## B

battery  
    safety information, 75

## C

CAN connection, 13  
CAN failure, 39  
capillaries, 65  
capillary kits, 62  
column organizer, 12  
column selection, 54  
    analytical scale, 55  
configuration, software, 15  
crystal formation, 31

## D

DC-CAN Cable, 14  
delivery checklist, 9  
diagnostics, 36

## E

early maintenance feedback (EMF), 23, 26, 36  
EMF counter, 37  
EMF info pad, 36  
EMF limit, 23, 36

## F

ferrules, 64  
finger-tight fittings, 57  
fittings, 57, 64  
flow injection analysis, 54  
flow range, 68, 69, 70  
flushing, 54

## G

gradient elution, 44

## H

handheld controller, 22

## I

information  
    on uv-radiation, 78  
Instant Pilot, 24  
instrument actuals, 21  
internet, 79

## L

large volumes, 48

## M

method, 24

method development, 54  
method validation, 54  
micro valves, 31  
multi-column setup, 54

## N

notready, 38

## P

position, 18, 20  
position, unknown, 40  
pow. fail status, 39  
power supply, external, 14  
preparative scale  
    alternating column regeneration, 47  
Pump Configuration Kit, 52

## R

rebuild kit, 31  
rotor seal, 32, 34  
RRLC, 52

## S

safety information  
    on lithium batteries, 75  
sample enrichment, 48  
    analytical scale, 50  
sample matrix  
    removal, 48  
sample stripping, 49  
sample throughput, 44  
selection valve, 54  
sensitivity, 48  
setup valve, 18  
site requirements, 8

## Index

- solvent selection, 56
  - tubing kit, 57
- specifications, 67
- stator face, 32
- stator head, 32, 34
- stator ring, 32, 34
- Status Indicators, 30
- switch failure, 39
- switching the valve, 22
- synchronization, 22, 27, 41
- system errors, 38

## T

- time table, 20
- timetable, 25
- troubleshooting, 38
- tubing kit, 57, 62

## U

- unknown position, 40
- use current, 18
- uv-radiation, 78

## V

- valve assemblies, 60
- valve configuration, 16
- valve head, 32, 34
- valve name, 19
- valve parameters, 18
- valve synchronization, 41



## In This Book

This User's Guide describes common applications as well as installation, operation and maintenance of the following Agilent 1200 series valves:

- G1157A Agilent 1200 Series  
2 Position/10 Port Valve
- G1158A Agilent 1200 Series  
2 Position/ 6 Port Valve
- G1158B Agilent 1200 Series  
2 Position/ 6 Port Valve (600 bar)
- G1159A Agilent 1200 Series  
6 Position Selection Valve
- G1160A Agilent 1200 Series  
12 Position/13 Port Selection Valve
- G1162A Agilent 1200 Series  
2 Position/ 6 Port Micro Valve
- G1163A Agilent 1200 Series  
2 Position/10 Port Micro Valve

In addition parts and specifications of these valves are listed.

© Agilent Technologies 2006, 2007

Printed in Germany  
11/07



G1156-90011



**Agilent Technologies**