

How to Keep and Good Thing Going: Preventative and Routine Maintenance for Your GC System

Alexander Ucci
Online Application Engineer
December 5, 2023



The Million Dollar Question – How Long Will My Consumables Last?

- One of the most common questions in technical support
- Highly dependent on many factors
 - How often do you use your instrument?
 - How contaminated is your sample?
 - Leaks present?
 - Using proper supplies to begin with?
- With experience you will observe the signs and symptoms of when it is time to replace a consumable
- It's important to have something to compare to
 - Instrument blank
 - Clean standard injection

Know What your Baseline Should Look Like – the Instrument Blank

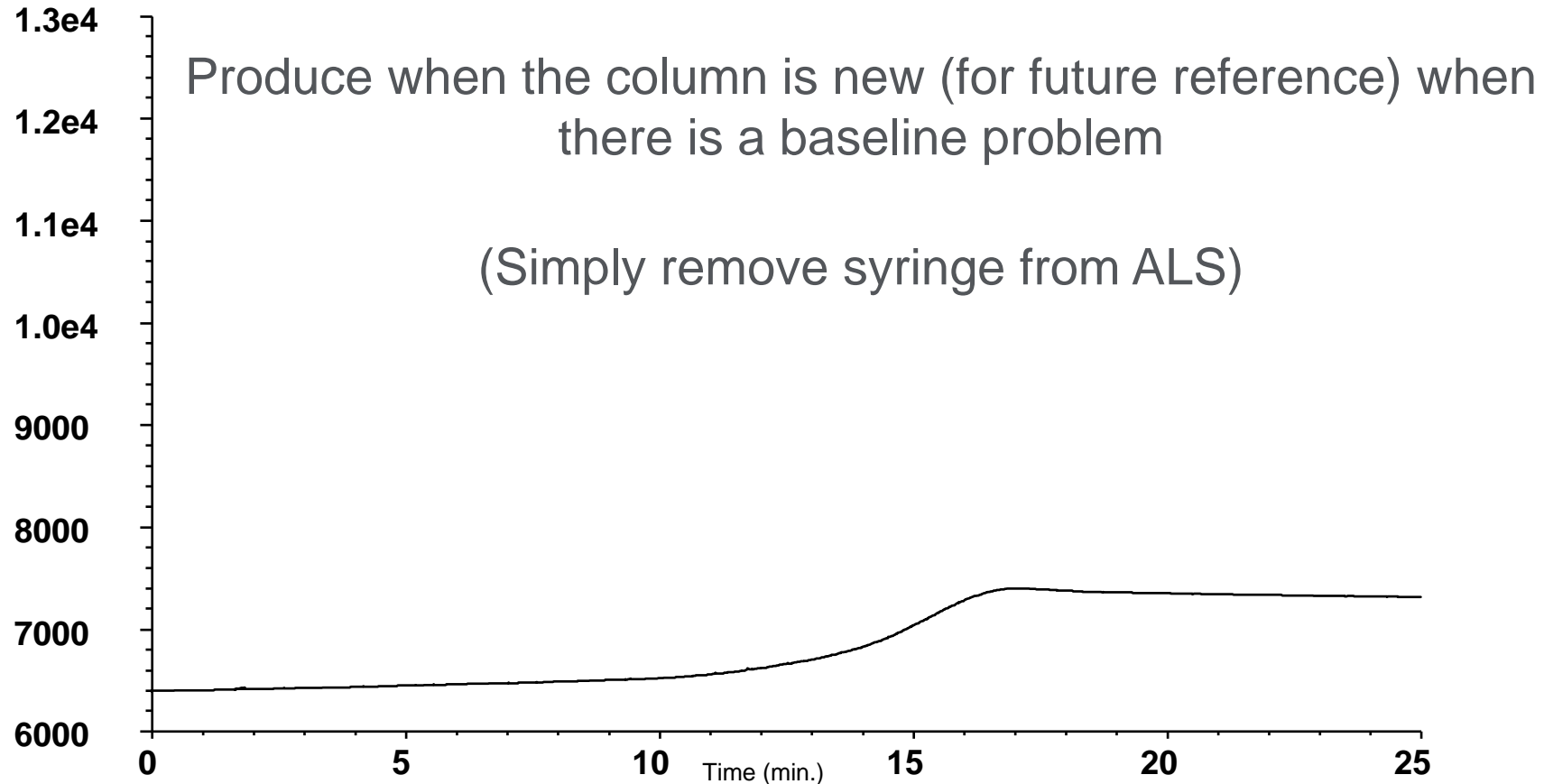

Agilent J&W DB-1, 30 m x 0.32 mm id, 0.25 μ m
Temperature program: 40 °C, hold 1 min // 20 °C/min to 320 °C,
hold 10 min.

Inject a Clean Test Mix

A test mix is used to determine how “good” the column is, or whether the problem is related to the chemical properties of the analytes.

It is simplest to use your own standard.

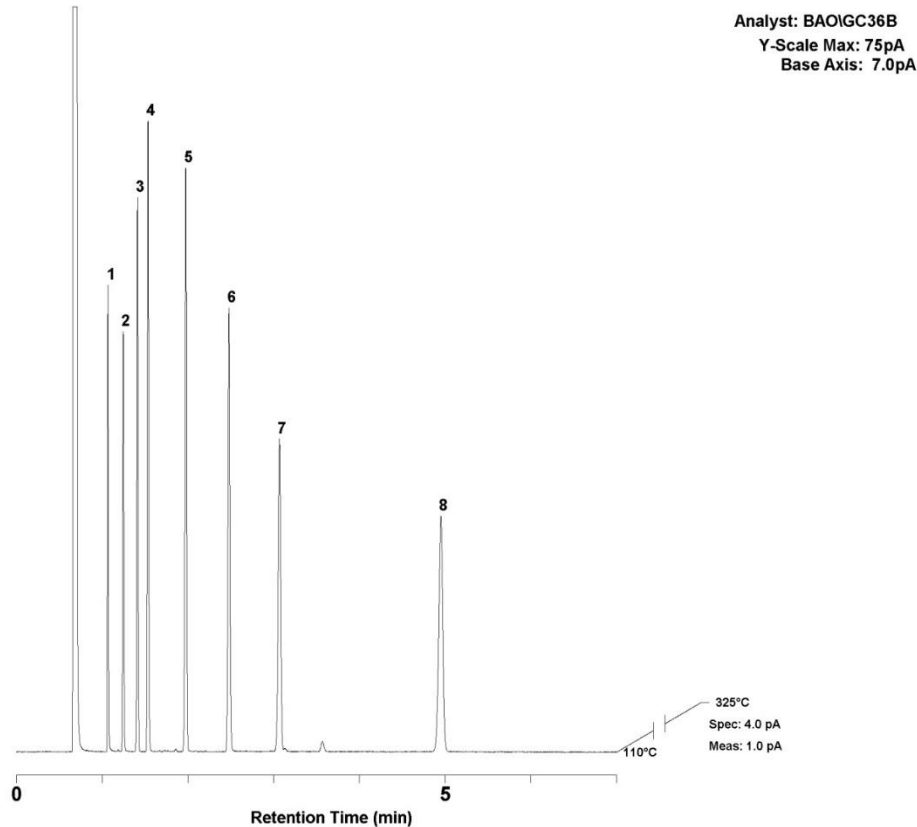

Compound	Purpose
Hydrocarbons	Efficiency retention
Alcohols	Activity
FAMEs, PAHs	Retention
Acids	Acidic character activity
Bases	Basic character activity

Test Conditions	
Inlet:	Split (250 °C)
Detector:	FID (320 °C)
Flow:	37.3 cm/s (1.8 mL/min)
Carrier gas:	Hydrogen
Holdup compound:	Methane (0.671 min)
Temperature program:	Isothermal (110 °C)

Standards Selection

Agilent ULTRA Chemical Standards have:

- Excellent online search, compare, and ordering capabilities
- Rapid shipping: 99.9% of orders are dispatched within 24 to 48 hours (continental U.S. only, as of now)
- Custom standard solutions, including our online custom quoting tool, enabling customers to upload recipe formulations and to modify the recipe before submitting it
 - The tool allows customers to see the quote pricing instantly and lets them check the pricing based on quantity range
 - Discover more at www.agilent.com/en/product/chemical-standards
- Rigorously tested and manufactured under ISO 9001, ISO 17025, and ISO 17034 accreditation
- Sample preparation materials, columns, supplies, instrumentation, and reference materials from a single source



When to Change your Standards?

All standards come with an expiration date and storage conditions

- **Information** is listed on the Certificate of Analysis (CofA)
- **Expiration** date depends on the stability of the analytes in the solvent
- Standards are guaranteed to this date for unopened ampoules or bottles

Standards made with volatile solvents and analytes should only be used once

- **It is too risky and the concentrations of the analytes may not match the certificate once opened**

If not highly volatile, stability of the standard and any stock solutions, calibration standards, or verification standards must be monitored by the end user

Agency methods will often have guidelines for usage, storage, and stability of standards and stock solutions.

ISO 17034



Trusted Answers

Reference Material Certificate

Product Name: PAH Analyzer Calibration Sample #2 **Lot Number:** 0006646719
Product Number: G3440-85009-2 **Lot Issue Date:** 28-Oct-2021
Storage Conditions: Store at Room Temperature (15° to 30°C). **Expiration Date:** 31-Oct-2023

Component Name	CERTIFIED VALUES		CAS#	Analyte Lot
	Concentration	Expanded Uncertainty		
naphthalene-d8	50.0 ± 0.3 µg/mL	001146-65-2	RM12698	
acenaphthene-d10	50.2 ± 0.3 µg/mL	015067-26-2	RM13902	
phenanthrene-d10	50.0 ± 0.3 µg/mL	001517-22-2	RM06967	
chrysene-d12	50.0 ± 0.3 µg/mL	001719-03-5	RM15976	
perylene-d12	50.1 ± 0.3 µg/mL	001520-96-3	RM12612	

Matrix: acetone

Description:
This document is prepared in accordance with ISO 17034 and Guide 31. This analytical reference material standard was manufactured and verified in accordance with an ISO 9001 registered quality system and analyte concentrations were verified by an ISO 17025 accredited laboratory. The concentration and uncertainty value at the 95% confidence level for each analyte, determined gravimetrically, is listed above.

Traceability:
The balances used for these measurements are calibrated with weights traceable to NIST in compliance with ANSI/NCSL Z540.3, ISO 9001, ISO 17025, and ISO 17034. Calibrated Class A glassware is used for volumetric measurements. Thermometers are calibrated against a NIST traceable thermometer in accordance with NIST Special Publication 1088.

Homogeneity:
This analytical reference standard was unitized according to an in-house procedure and is guaranteed to be homogeneous. There is no minimum sub-sample size required.

Instructions for Use:
Sample aliquots for analysis should be withdrawn at 20°C to 25°C immediately after opening the container and should be processed without delay for the certified values to be valid within the stated uncertainties.

Safety:
Refer to the Safety Data Sheet on www.agilent.com for information regarding this analytical reference material.

Intended Use:
This analytical reference standard is intended for the preparation of working reference samples for use in routine laboratory analyses, calibration of instruments, validation of analytical methods, assessments of measurement methods, and continuing calibration verification.

Expiration of Certification:

Page: 1 of 2
CSD-QA-015.1

An Overview of the Commonly Changed GC Supplies

Gas traps
Standards

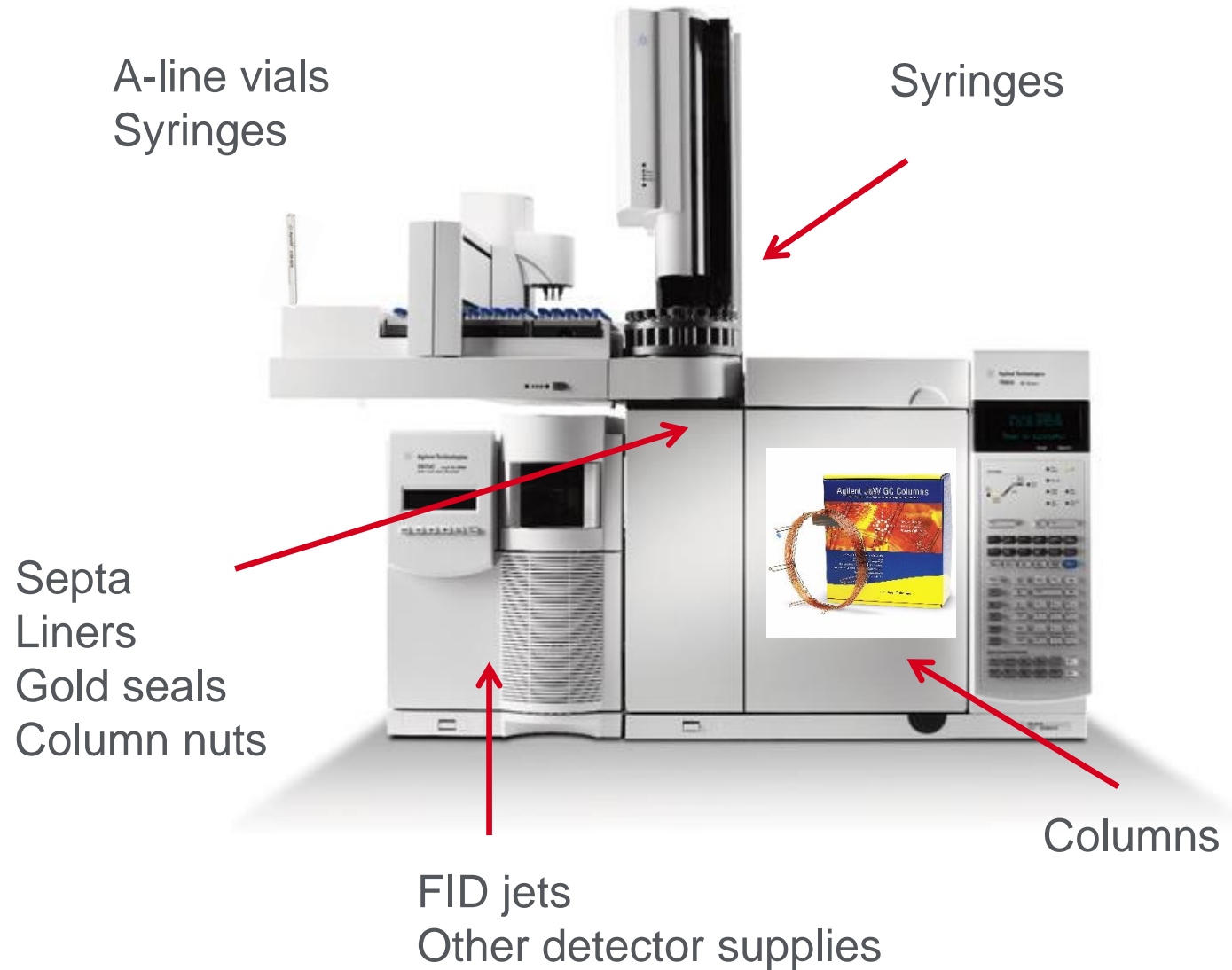

Let's Talk About Gas Quality and Filters

- Oxygen in carrier gas is detrimental to GC/MS
 - Reduced response
 - Elevated background
 - Irreversible column damage
 - Impaired electron multiplier function
 - Premature filament, liner lifetime
- Use UHP carrier gases
 - 99.9995% or greater
- Use Gas Clean carrier gas filters

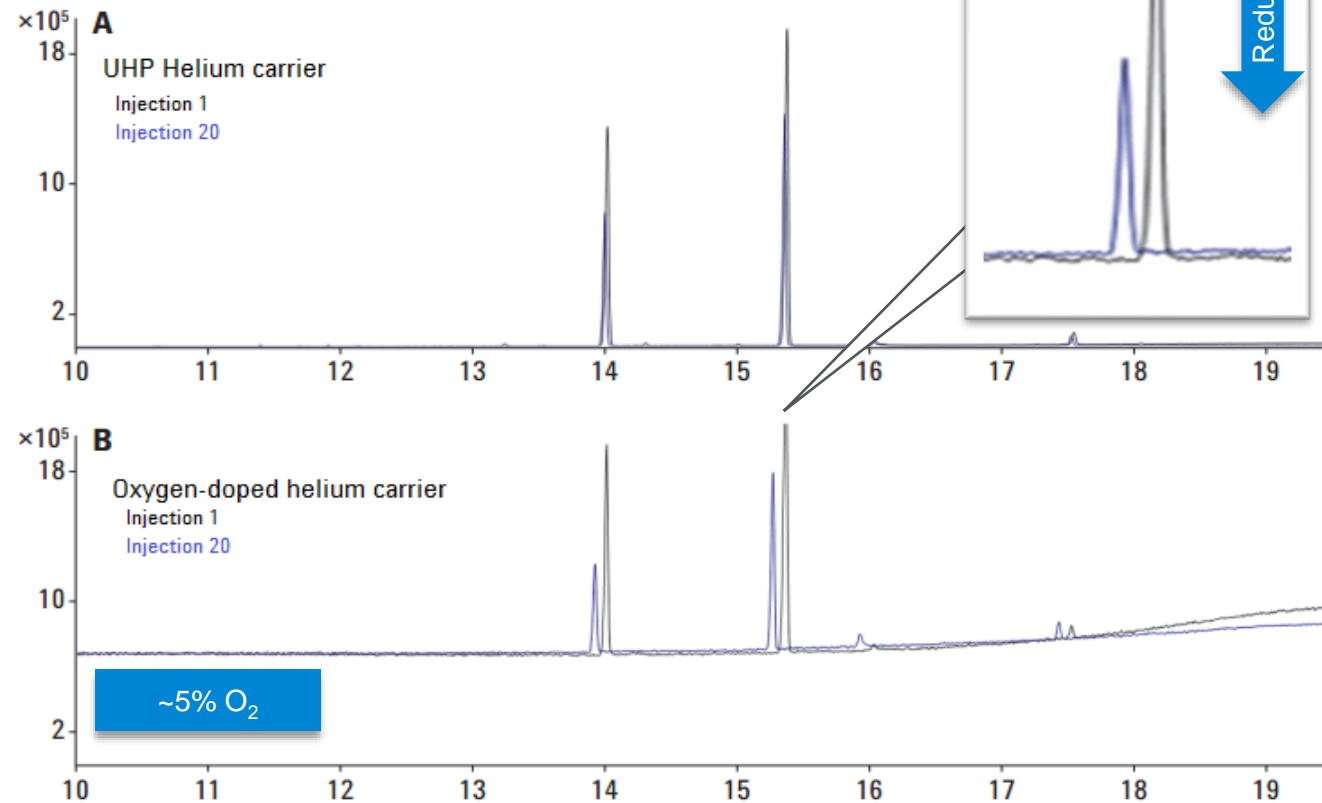

GC/MS filter
Agilent p/n
CP17973

Let's Talk About Gas Quality and Filters

If you used lower quality gases, how much O₂ could the filter clean up?

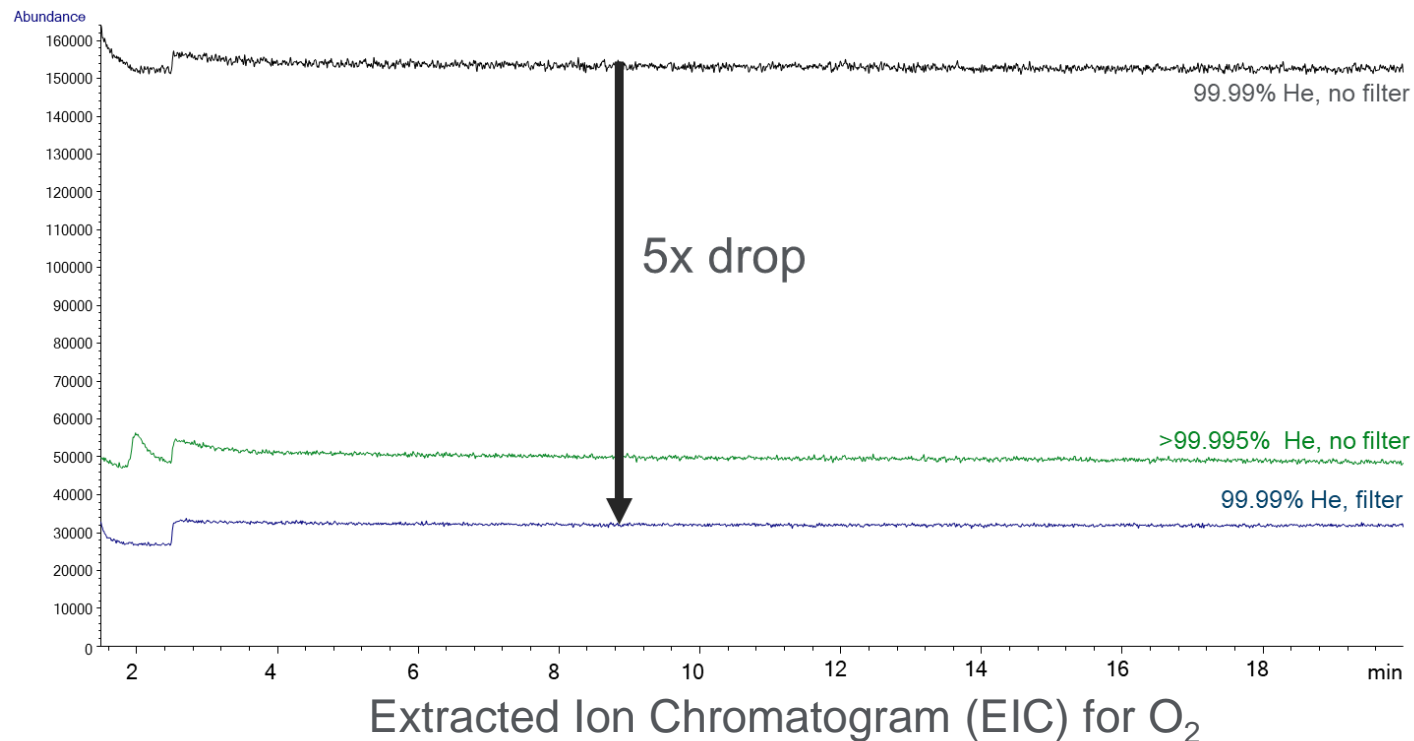

Installing (and properly purging) the Gas Clean carrier gas filter lowers the O₂ signal by a **factor of 5**.



Let's Talk About Gas Quality and Filters

If you used lower quality gases, how much H₂O could the filter clean up?

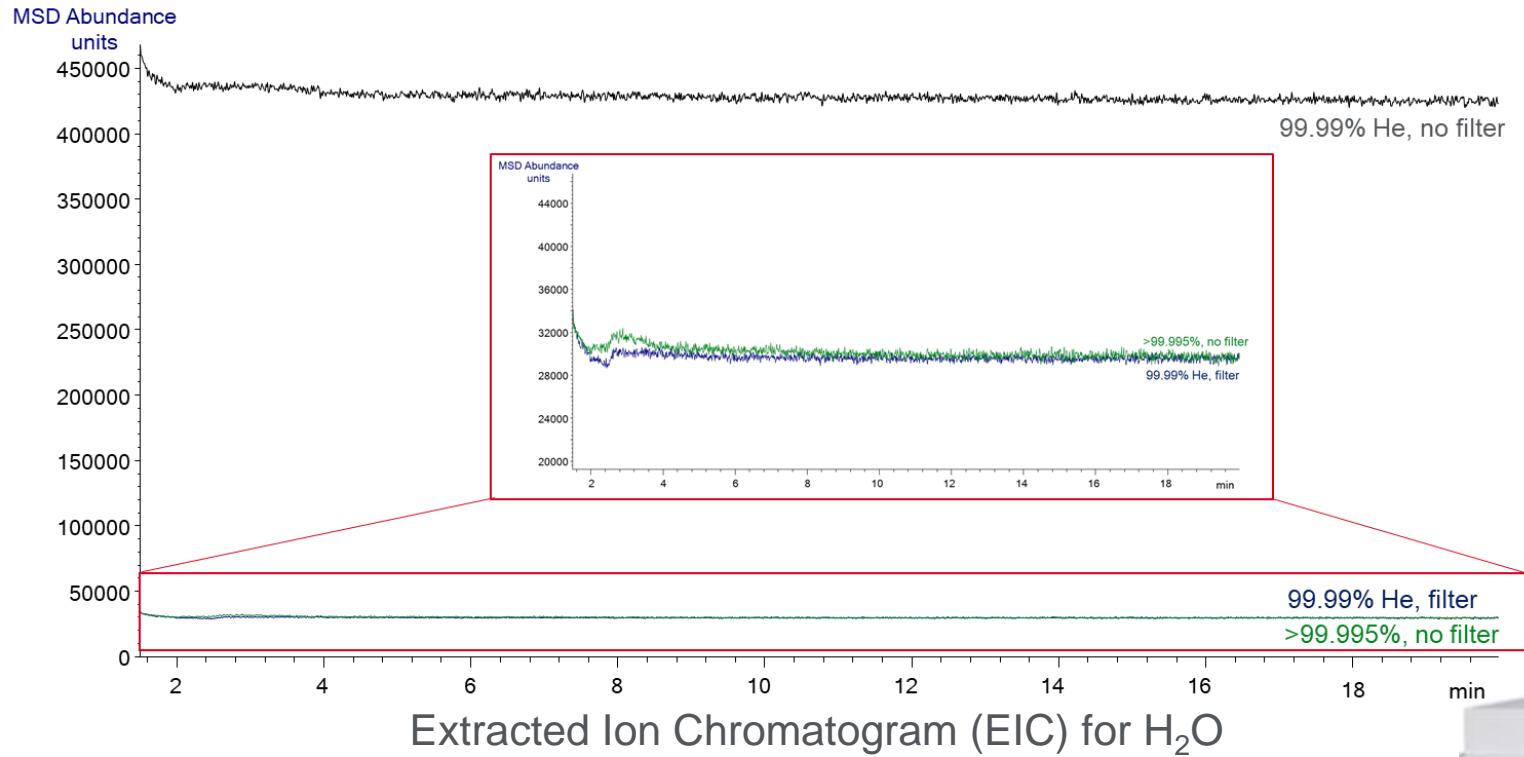

Gas Clean filter lowered the H₂O signal by a **factor >10**

You can further increase Gas Clean and column lifetime by installing the universal filter before the Gas Clean filter.



Let's Talk About Gas Quality and Filters

If lower quality gases were used, how much background could the filter clean up?

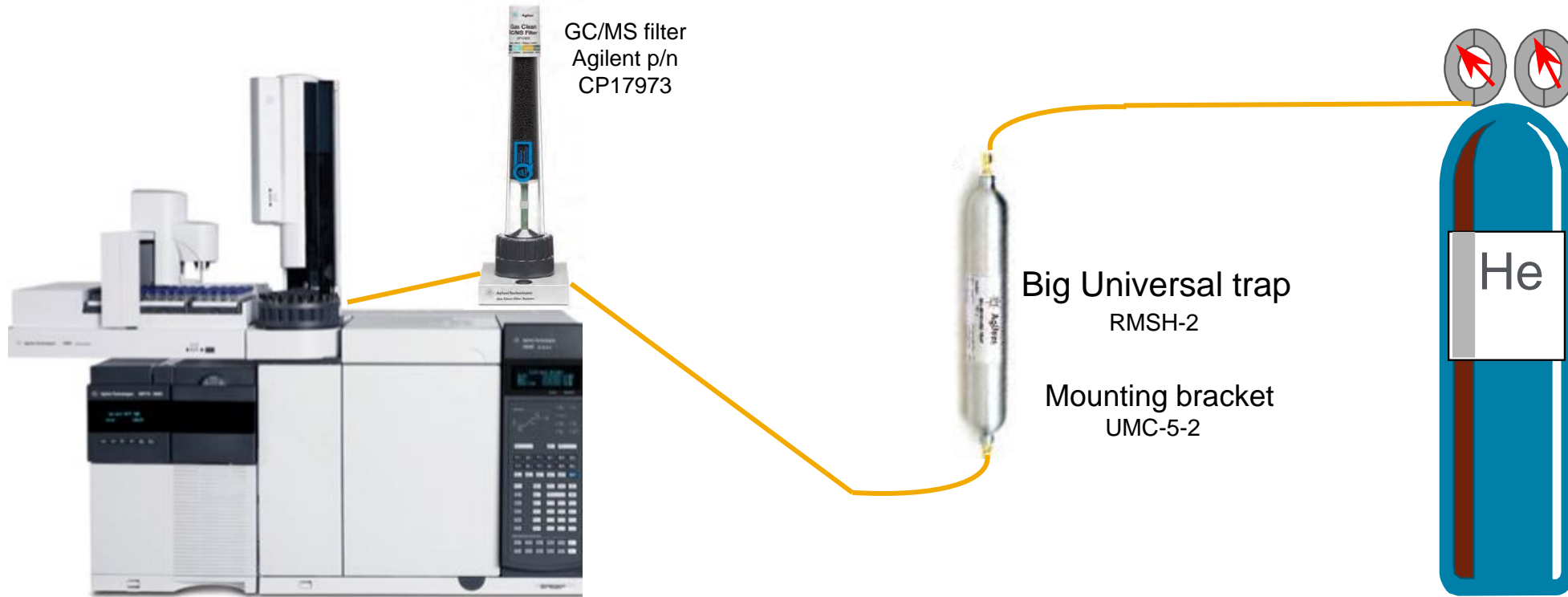

- Install the Universal trap vertically – use the mounting bracket(s)
- Extend the lifetime of your Gas Clean (indicating) filter **and** your column

Gas Trap Indicators Help Tell You When it's Time to Change Them

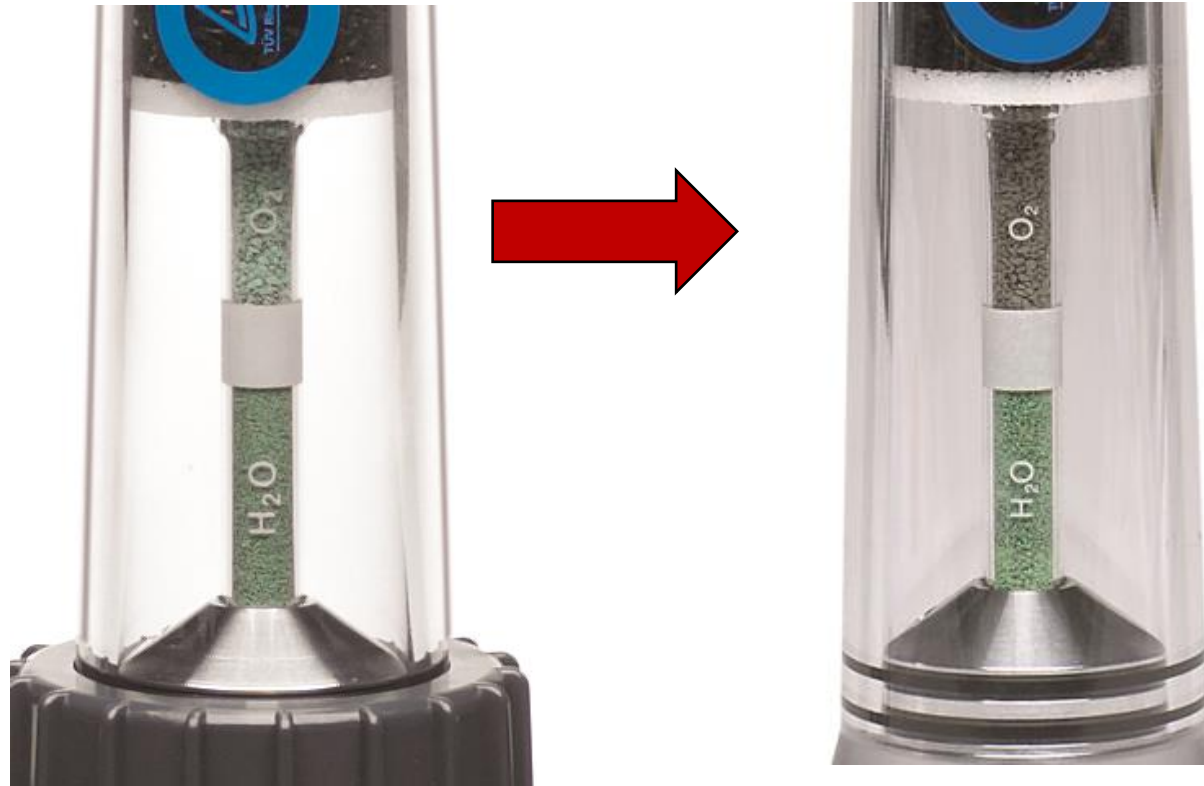

If there are no indicators, then change them periodically or according to your SOP.

Vials – Only Use Once

- Choose high-quality vials and caps
 - Poorly constructed vial septa → siloxanes → bleed peaks
 - Low-quality vial → **contaminants can leach into sample**
 - Choose the right cap/septa for your solvent

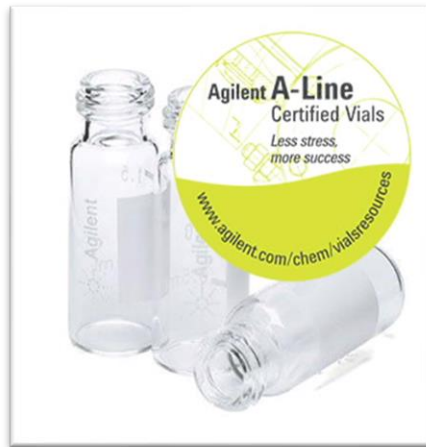

	High performance septa	Thin PTFE	PTFE/Silicone*	PTFE/Silicone/PTFE*	PTFE/Red rubber	Flouroelastomer	Butyl
Temperature range	40 °C to 300 °C**	Up to 260 °C	–40 °C to 200 °C	–40 °C to 200 °C	–40 °C to 90 °C	–40 °C to 260 °C	–50 °C to 150 °C
Use for multiple injections	No	No	Yes	Yes	No	No	No
Price	More expensive	Very economical	Economical	Most expensive	Very economical	Economical	Economical
Resistance to coring	Excellent	None	Excellent	Excellent	None	None	None
Recommended for storage	No	No	Yes	Yes	No	No	No
Best for	High temperature headspace applications	Superior chemical inertness, short cycle times, and single injections	Most common HPLC and GC analyses, not as resistant to coring as P/S/P	Superior performance for ultra trace analysis, repeat injections, and internal standards	Chlorosilanes, more economical option for single injections	Chlorinated solvents, higher temperatures	Organic solvents, acetic acids, impermeable to gases

* Agilent silicone is platinum cured (versus peroxide cured), making it more inert and less likely to interact with samples.

** For up to 1 hour.

Syringes – Use Until it Breaks or is too Dirty

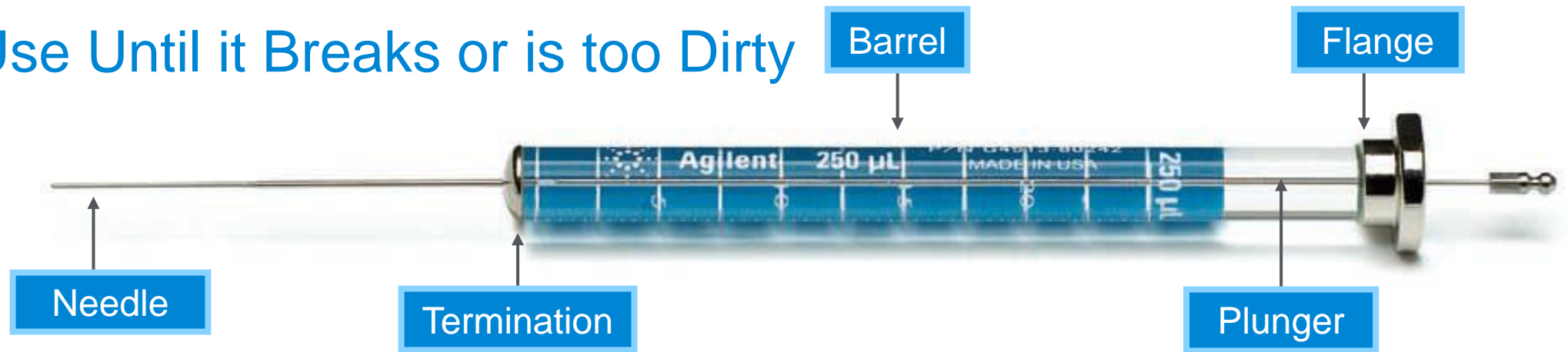

Standard plungers

- Fit tightly within syringe barrel
- Limit loss of volatile sample
- Individually fitted to the syringe
- Not replaceable or interchangeable
- Recommended for analysis of liquid samples

PTFE-tipped (shown)

- Limit sample deposit adsorption
- **Forms gas-tight seal**
- Replaceable
- Requires maintenance to maintain PTFE seal
- Recommended for:
 - “Dirty” samples
 - Highly volatile samples
 - Gas injections
 - Chlorinated solvents

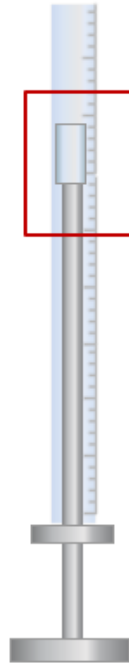

Troubleshooting

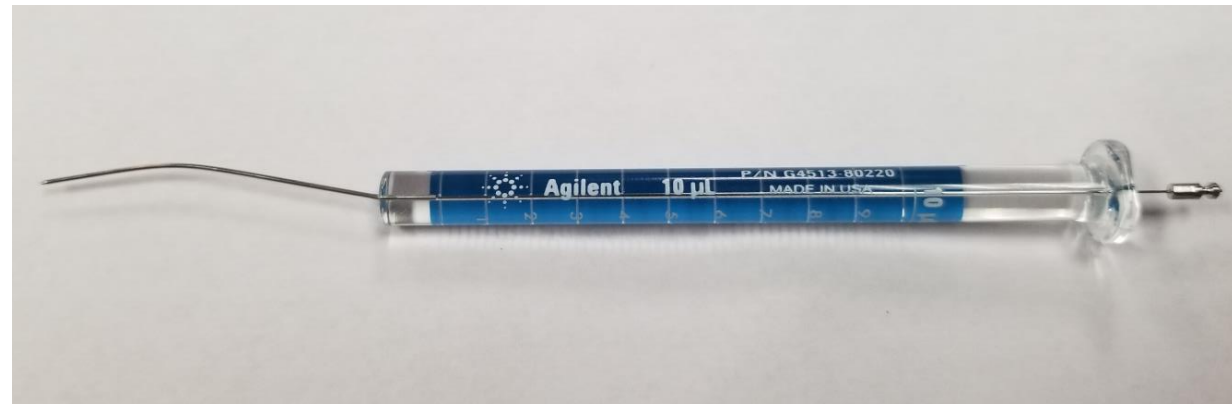

Troubleshooting

Problem: Bent Plunger or stuck syringe

Possible causes:

- Particles such as dust, salts, metal, leftover sample, or glass can fill the narrow gap between the plunger shaft and the inside wall of the barrel.
- Overtightened septum nut compresses septa, causing excessive resistance during injection

Suggested actions:

- Switch to a syringe with PTFE-tipped plunger
- Avoid using 5 μ L syringes where possible
- If plunger movement feels “gritty”, carefully remove plunger from barrel, flush with solvent, and wipe dry with lint-free cloth. Carefully reinsert plunger into barrel. Finally, submerge needle tip into container of solvent and cycle plunger to pull solvent into and out of the barrel.
- Never cycle the plunger in a dry syringe
- Do not “mix-and-match” plungers and barrels
- Immediately clean syringes after use
- Loosen septum nut



Troubleshooting

Problem: Bent needle

Possible causes:

- Improper needle alignment
- Narrow gauge needles (26 g) bend more easily than larger gauge (23 g) needles
- Needles tend to bend when inserted into sample vial, not the inlet. This can be caused by septa that are too “rough”.
- Needles bent during installation into the autosampler are more likely to bend when pushed through the sample vial cap septum.
- Oncolumn inlets – wrong needle gauge
 - Use correct needle support

Suggested actions:

- Use syringes with 23 to 26 gauge tapered needles
- Realign autosampler
- Check septum nut is not over-tight



Washes and Pumps: Solvents

Frequently clean or replace wash vials

- Traces of previous samples will accumulate over time
- Do not refill or “top-off” the vial, instead empty, rinse, and replace solvent
- Use a cotton swab to remove particulates from the glass surface

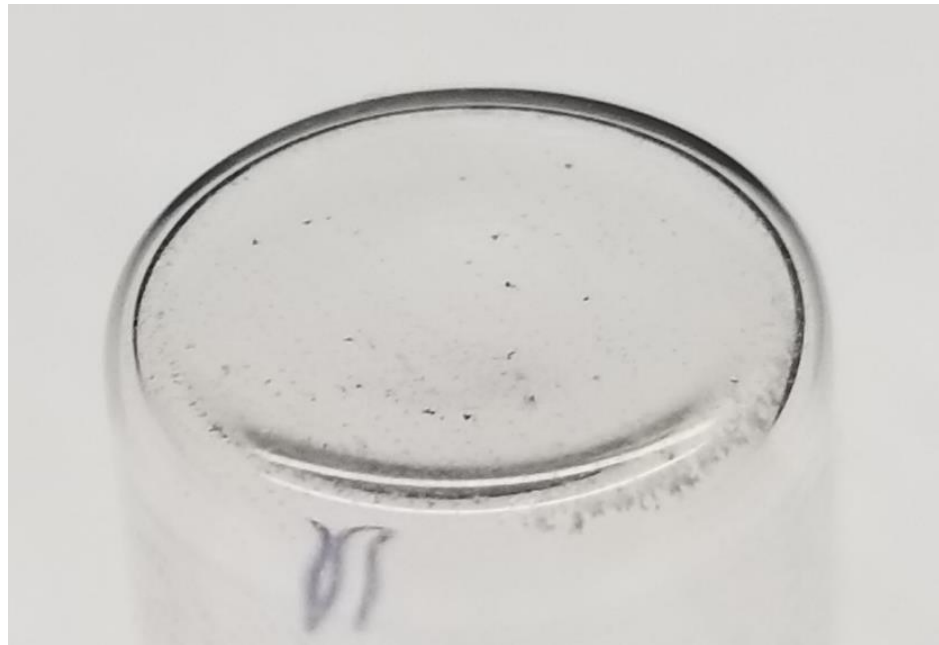

Contaminated wash vial bottom

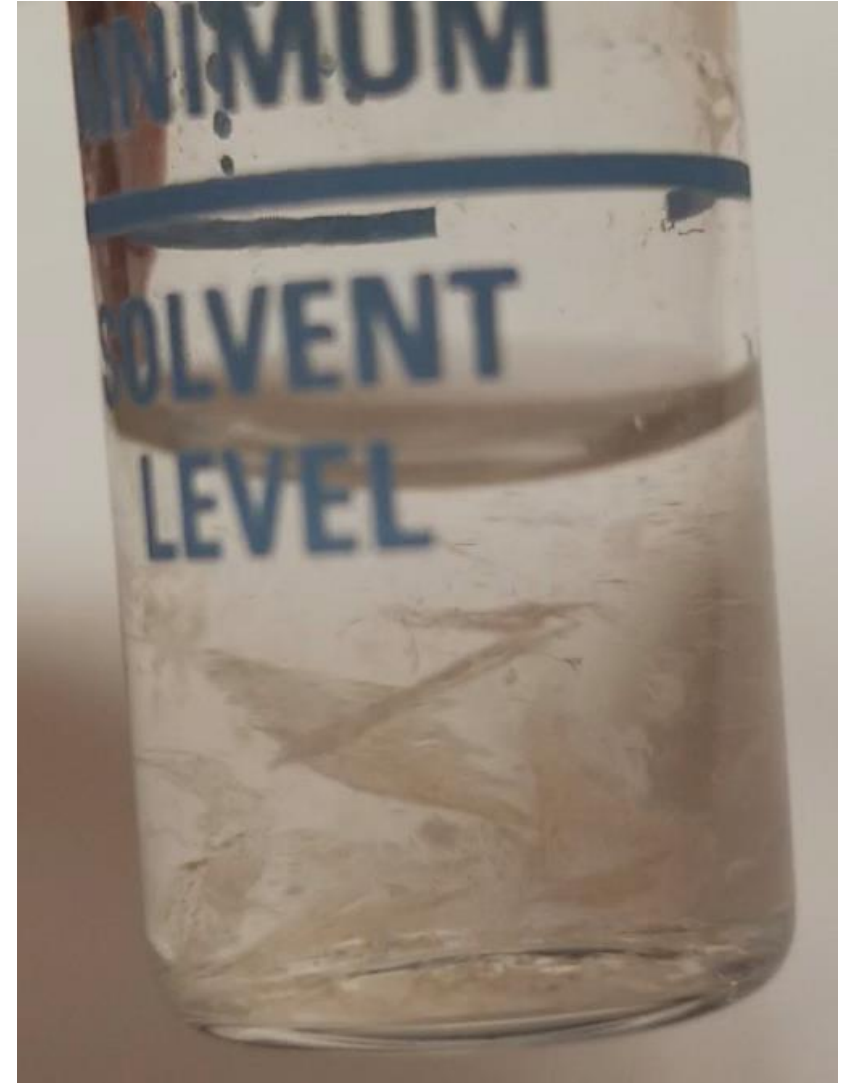

Contaminated wash solvent

Washes and Pumps: Solvents

Choose a wash solvent or a series of solvents that make sense for the analysis

- Is the analyte soluble in the solvent?
- Wash solvent = sample solvent when possible
- If wash solvent \neq sample solvent, are they miscible?
- If using a binary wash system, make sure solvents are miscible and rinse with the sample solvent last just before the sample
- Do not use acidic or alkaline solvents with syringes
- What other solvents are used/analytes determined in methods on the same GC?



Use both A and B wash vials
Second wash vial will be cleaner than first
Second wash vial should never be water (rust)



Avoid viscous solvents and solvents with high vapor expansion volumes. Use the vapor volume calculator to make sure it will not overload the inlet liner.

Wash Vials

- 4 mL wash vials: 5182-0551
- Diffusion inserts: 07673-40180



Split Vent Trap: The Forgotten Consumable

Change every 6- 12 months

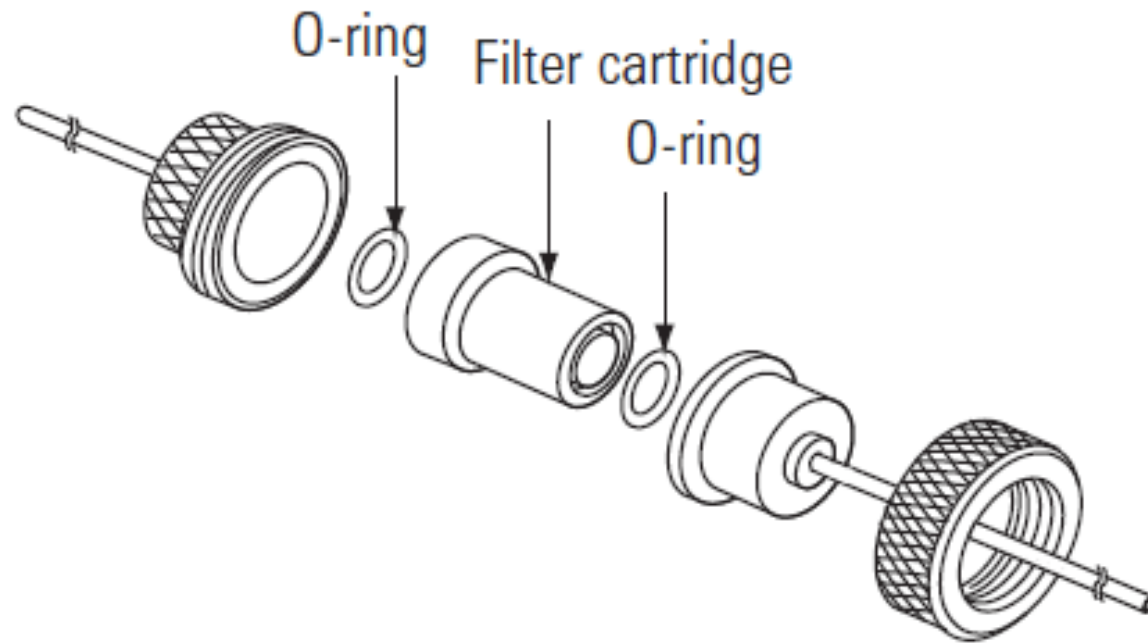

Split vent trap, 5188-6495

Inlet

- Injection efficiency:
 - Main function of the inlet is to produce a narrow sample band at the head of the column
 - One of the most important aspects of any high-resolution GC method
- Must be reproducible
- The liner volume must be large enough to accommodate the solvent's phase transformation into a vapor (backflash)
- Most chromatography problems are “front-end” related
- **There are** many consumables to replace: septa, liner, gold seal
- Inlet body must be cleaned/solvent rinsed periodically (**no steel brushes, please**)

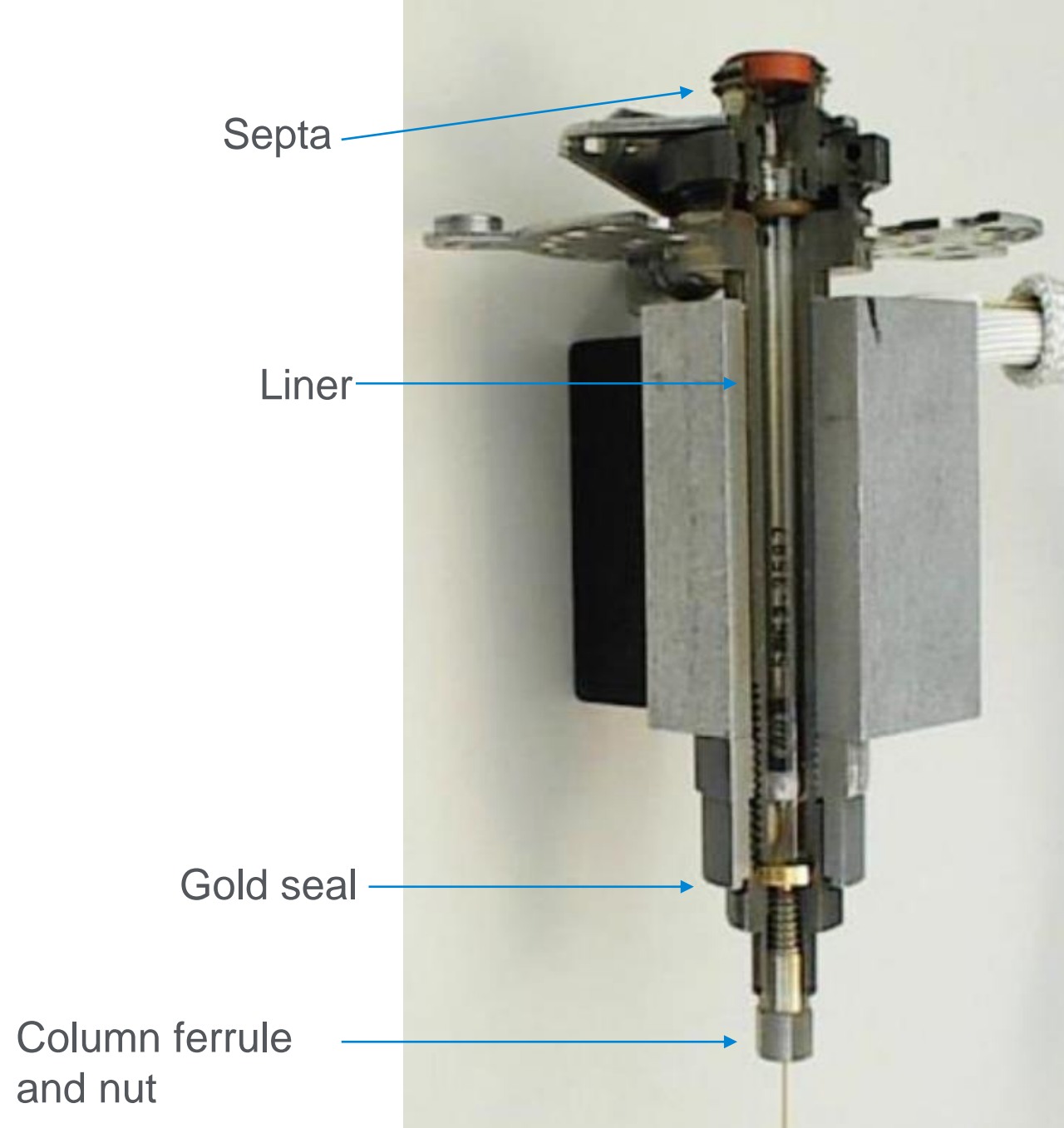

Septa

- Typical cost of one premium septum (list), \$1.25
- Typical cost of one GC column, 30 m x 0.25 mm id, \$600
- Proactively change inlet septa
- Agilent packing eliminates contamination of septa
- “CenterGuide septa” puts less strain on syringe compared to solid septa
- Do not overtighten septum nut; septum can begin to “bulge” out
- Should tighten nut until c-clamp on top stops turning, then $\frac{1}{2}$ to $\frac{3}{4}$ turn more



Septum nut

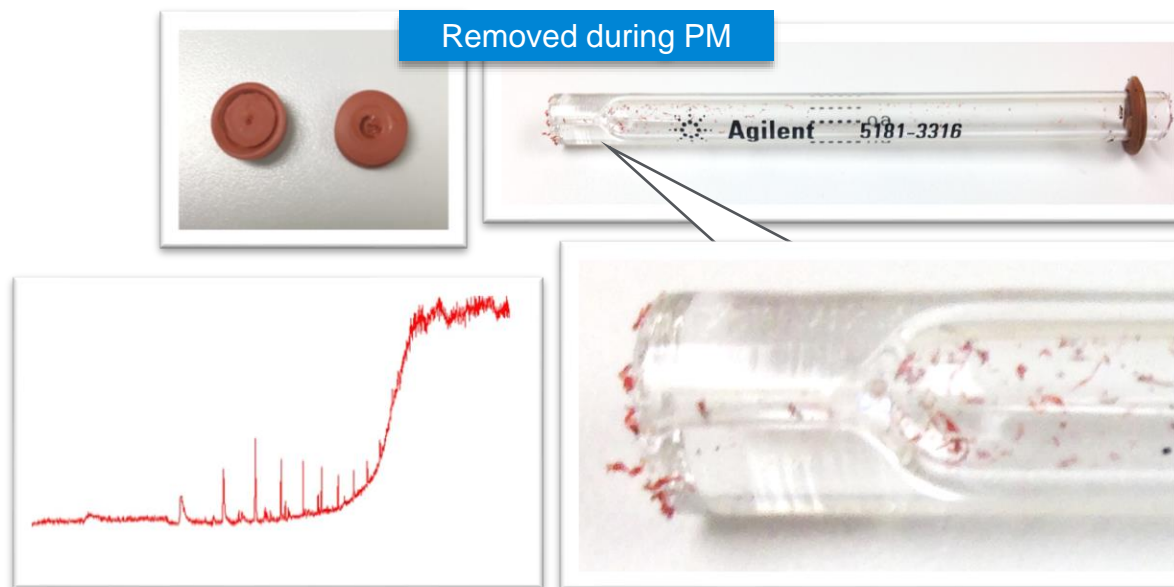

Septum maintenance: Septum coring

After many injections, pieces of rubber from the septum may break off and fall into the inlet liner.

- This is called septa coring
- Replace the inlet septa and liner frequently to prevent septa contamination
- Use a cone-tipped syringe to reduce the chance of tearing the septum
- This is also very common when making multiple injections from the same vial
- (it is not column bleed even though it looks like it spectrally)







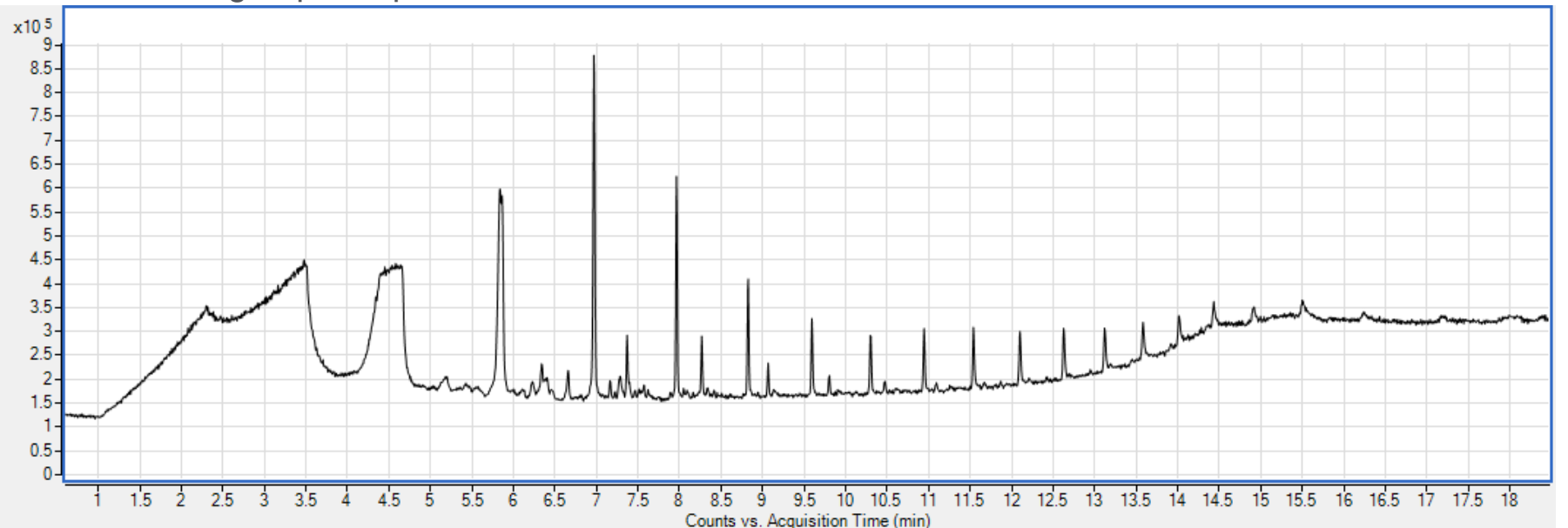



Septum core placed in a clean liner, and a blank injection is performed.

- Inlet: 320 °C, split mode, 10:1 split ratio
- Oven: 35 °C to 300 °C at 20 °C per minute
- Detector: Single quadrupole EI Scan, 35 to 500 amu



Liners – Change as Needed

Agilent Ultra Inert Liners

Description	Volume (µL)	ID (mm)	1/pk	5/pk	25/pk	100/pk*
Split Inlet Liners						
 Low pressure drop, Ultra Inert Liner with glass wool	870	4	5190-2295	5190-3165	5190-3169	5190-3173
 Straight, Ultra Inert Liner with glass wool	990	4	5190-2294	5190-3164	5190-3168	5190-3172
Splitless Inlet Liners						
 Single taper, Ultra Inert Liner	900	4	5190-2292	5190-3162	5190-3166	5190-3170
 Single taper, Ultra Inert Liner with glass wool	900	4	5190-2293	5190-3163	5190-3167	5190-3171
 Splitless, double taper Ultra Inert Liner, no wool	800	4	5190-3983	5190-4007		
 Dimpled, splitless, Ultra Inert Liner	200	2	5190-2297	5190-4006		
 Splitless, straight, Ultra Inert Liner	250	2	5190-6168			
 Straight, Ultra Inert Liner	60	1	5190-4047			
 Straight Ultra Inert Liner for SPME	35	0.75	5190-4048			

*The 100/pk is not in the Touchless packaging. O-rings must be purchased separately, p/n 5190-2269.

Liner Contamination

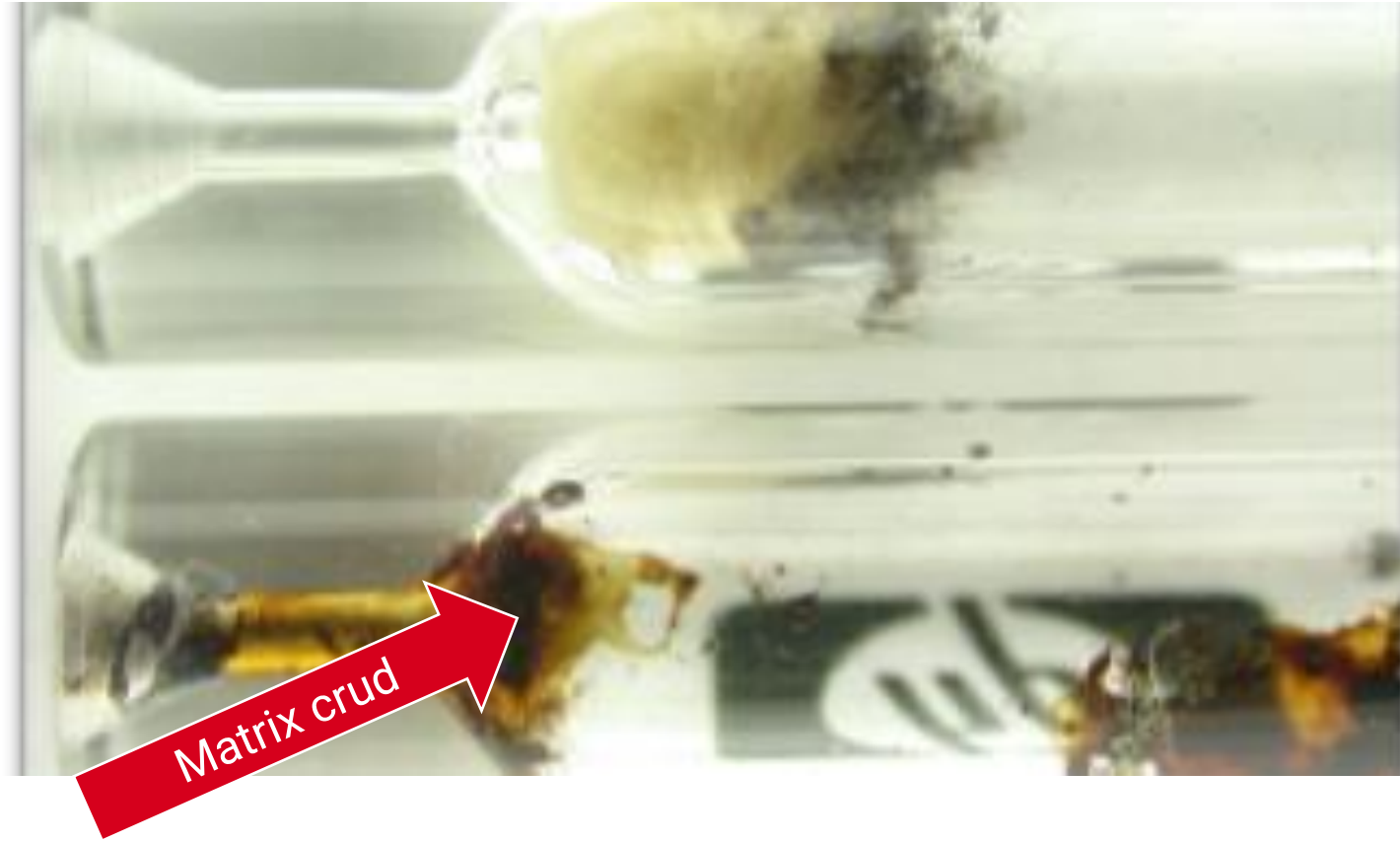

What's New? Glass Wool Alternative Liners

Ultra Inert liners with sintered glass frits

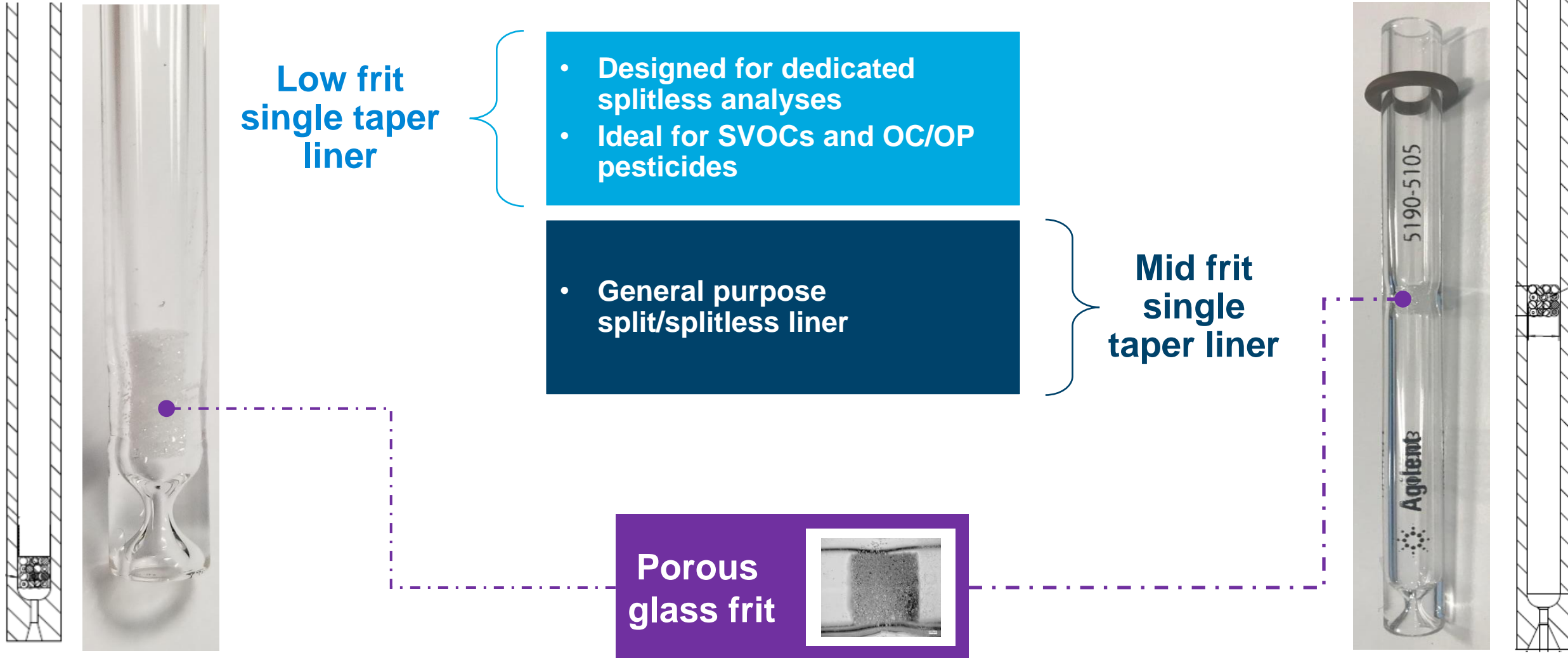

Packaging, Ease, and Productivity



Individual liner



Convenient 5/pk in
Touchless packaging



25/pk in Touchless
dispenser
High throughput



100/pk, bulk, blister
(no O-ring)
High throughput

Peak Broadening: Omethoate in Avocado in Run 1 versus Run 65

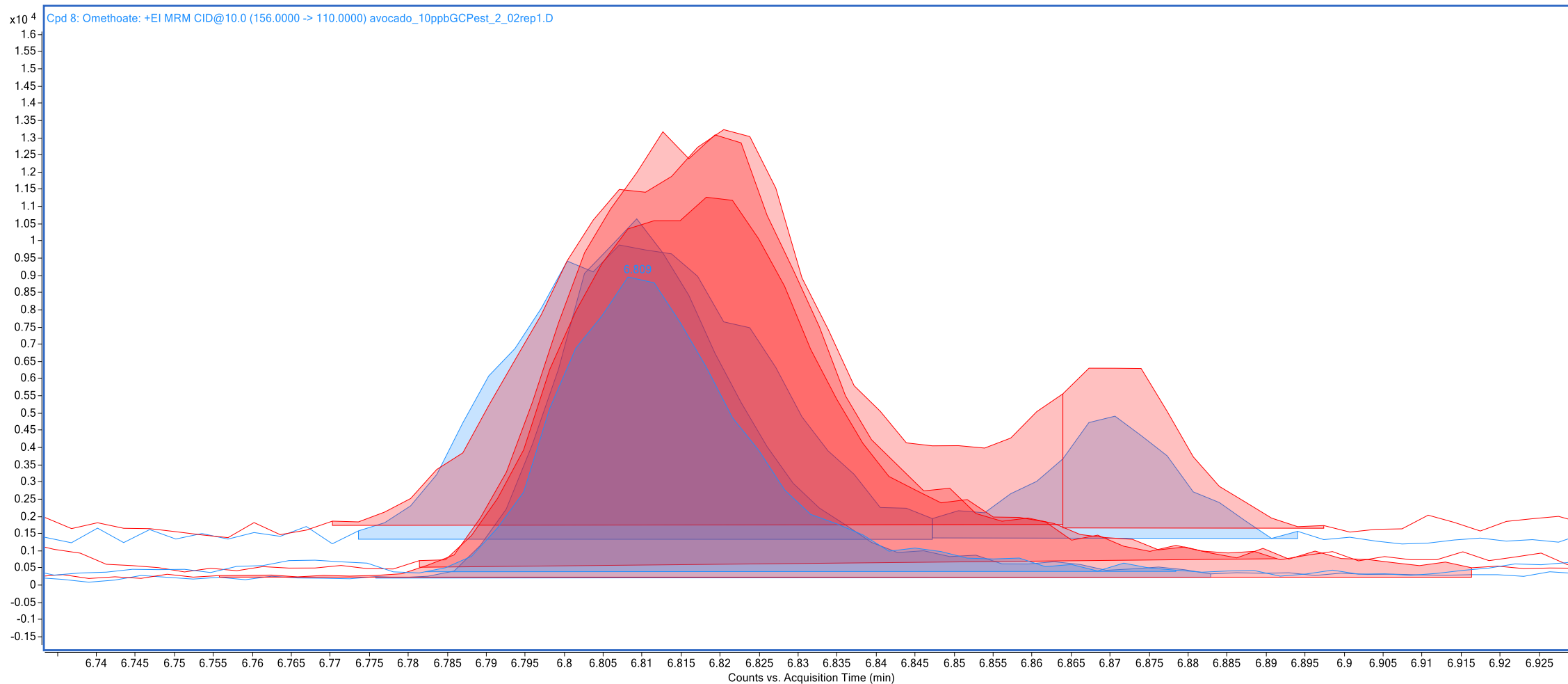

Peak Broadening: Recover Peak Shape with New Liner

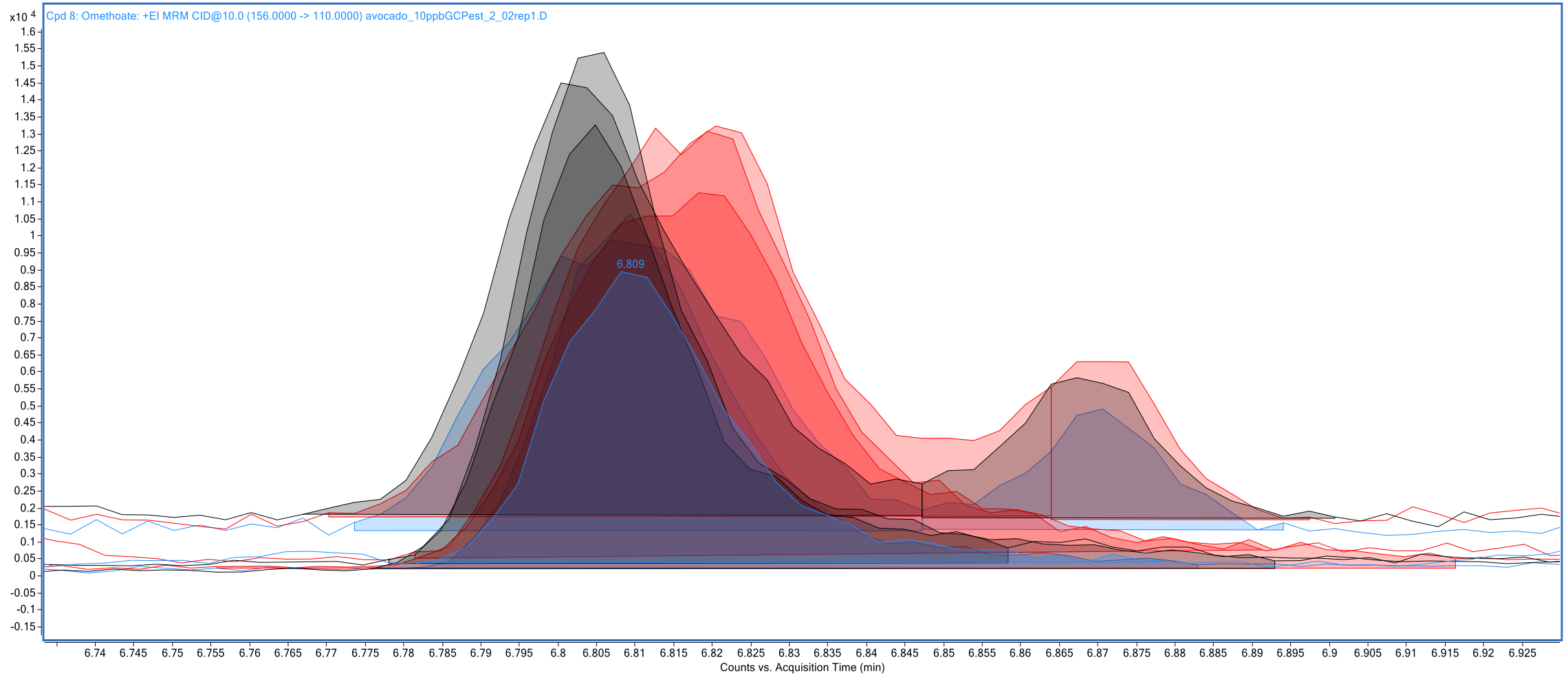

Agilent UI Gold Seal: Deactivated Gold Surface

- Soft gold plating is essential for proper sealing
- Ultra Inert chemistry blocks active sites (gold is **not** inert)
- Smooth surface doesn't leak (injection molded)
- Part numbers 5190-6144 (ea) 5190-6145 (10/pk), 5190-6149 (50/pk)

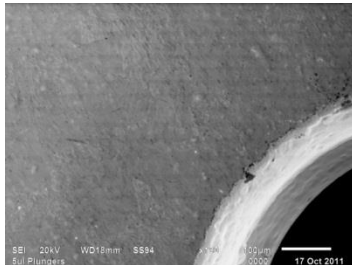

Agilent MIM seal

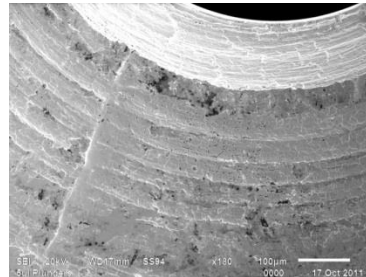

Competitor's
machined seal

Reliable ppb and ppt
measurements require
attention to the little things

Peak Tailing from Contaminated Consumables

	Peak
0	Methane
1	2-Nonanone
2	Decanal
3	2,3-Butanediol
4	Ethylene Glycol
5	Dicyclohexylamine
6	Heptadecane
7	Aniline
8	Methyl Dodecanoate
9	2-Chlorophenol
10	1-Undecanol
11	Nonadecane

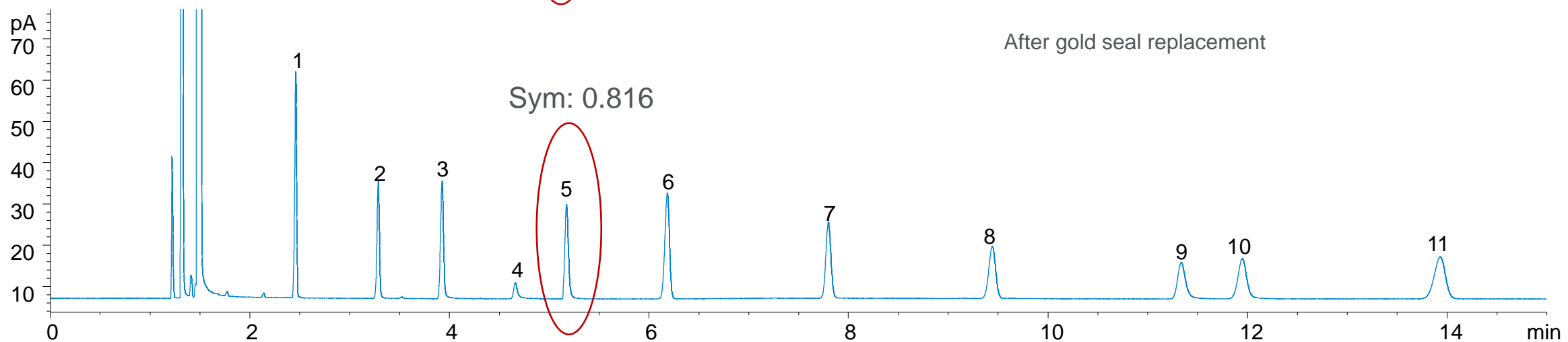
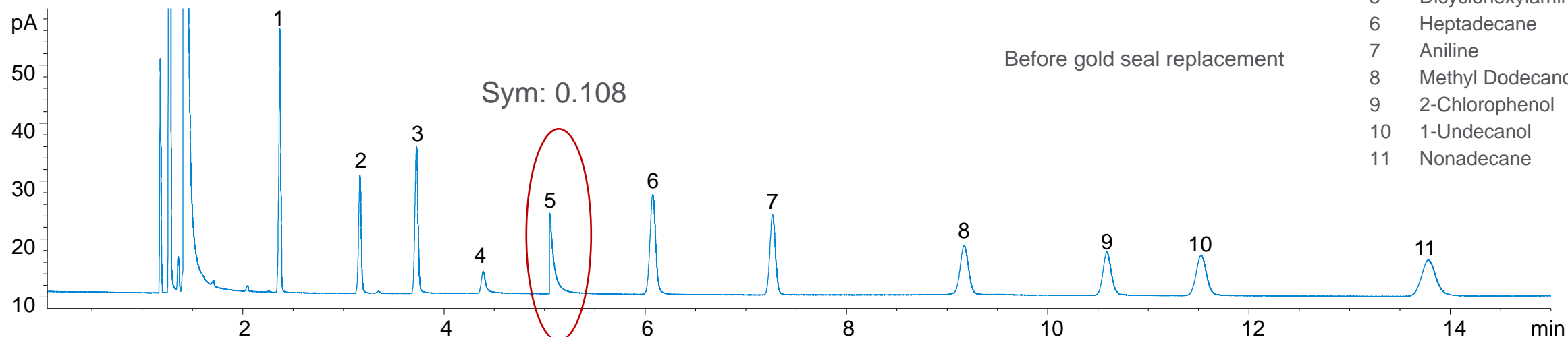

Column Installation

What type of ferrule should I use?



Polyimide



Graphite



Polyimide/
graphite



Flexible
Metal

Composition	Re-use	Max Temperature (°C)	Use	Limitation
Polyimide (Vespel)	Yes	280	Easy seal	Can shrink after heating, causing leaks after thermal cycle; isothermal only
Graphite	Yes	450	FID, NPD, inlets	Contamination, permeable to air – not for oxygen-sensitive detectors
Polyimide/graphite (85% / 15%)	Limited	350	MS, ECD, inlets	Can still shrink after thermal cycles, creating leaks; need to retighten regularly
Flexible Metal	No	450	Capillary flow technology (backflush, splitters)	May not seal well with damaged fittings or rough surfaces



“Short” ferrules for inlet and detector configurations on Agilent GCs



“Long” ferrules for MS transfer lines and MS interface nut

General Ferrules – Use Only Once

Capillary Column Ferrules – for use with most brands of column, including DB, HP, CP, VF and Select columns

Column ID (mm)	Ferrule Nom ID	UltiMetal Plus Flexible Metal Ferrule Part No.	Graphite Short Ferrule Part No.	Polyimide Short Ferrule Part No.	85% Polyimide/ 15% Graphite Short Ferrule Part No.	Pre-Conditioned Long Ferrule 85% Polyimide/ 15% Graphite for MSD connection Part No.
0.025-0.05	0.4		500-2114	5062-3515	5062-3516	5062-3507
0.075	0.4		500-2114	5062-3515	5062-3516	5062-3507
0.1-0.25	0.4	G3188-27501	500-2114	5181-3322	5181-3323	5062-3508
0.1-0.25*	0.5		5080-8853	5062-3513	5062-3514	5062-3508
0.32	0.5	G3188-27502	5080-8853	5062-3513	5062-3514	5062-3506
0.45	0.8	G3188-27503	500-2118	5062-3511	5062-3512	5062-3538
0.53	0.8	G3188-27503	500-2118	5062-3511	5062-3512	5062-3538

Column Installation: Self-Tightening Column Nut

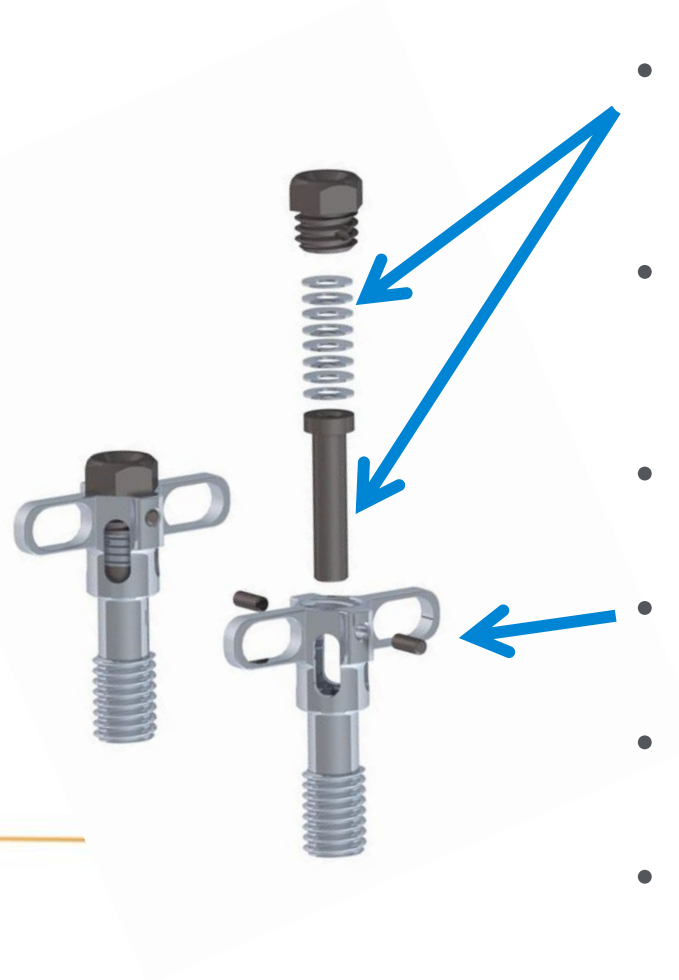
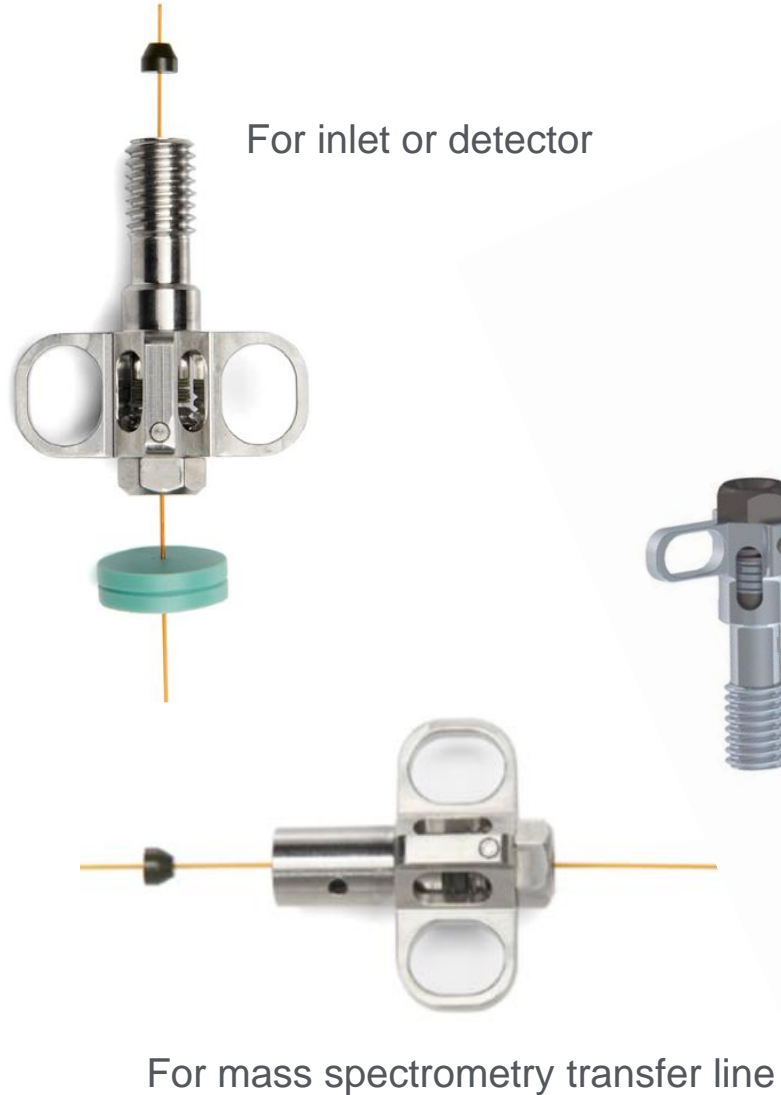

- Spring driven piston continuously presses against the ferrule
- Automatically retightens when ferrule shrinks
- No leaks, no downtime, no frustration
- Wing design for finger tightening
- No tools needed
- No polymer materials for durability
- Compatible with **only** short graphite/vespel ferrules

Increasing Ease-of-Use Through Continued Innovation: Self-Tightening Nuts



For GC inlet or detector

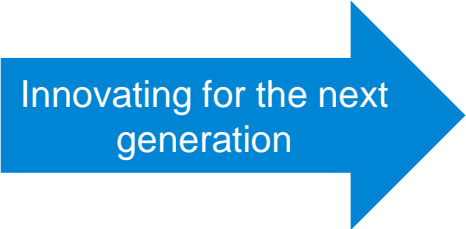

For mass spectrometry transfer line

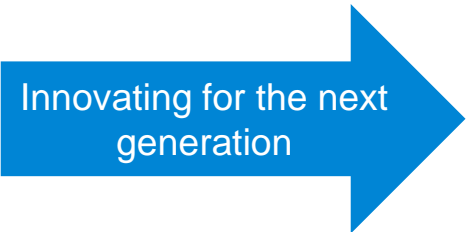

- Easier and faster to install
- Collar holds column in place
- Single-hand installation into inlet
- No tools needed



Self Tightening Nuts: No Leaks, No Downtime, No Frustration



- Spring-driven piston continuously presses against the ferrule
- Automatically retightens when ferrule shrinks
- Wing design for finger tightening
- No tools needed
- Works only with graphite/vespel ferrules

Part Number	Description
G3440-81013	Column Nut, Collared Self-Tightening MSD
G3440-81011	Column nut, Collared Self Tightening Inlet/Detect
G3440-81012	Collar for Self Tightening Nut

<https://www.agilent.com/en/video/gc-supplies-innovation>

<https://www.agilent.com/en/video/stcn-inlet-detector>

<https://www.agilent.com/en/video/stcn-mass-spec>

Standard column nuts new fitting

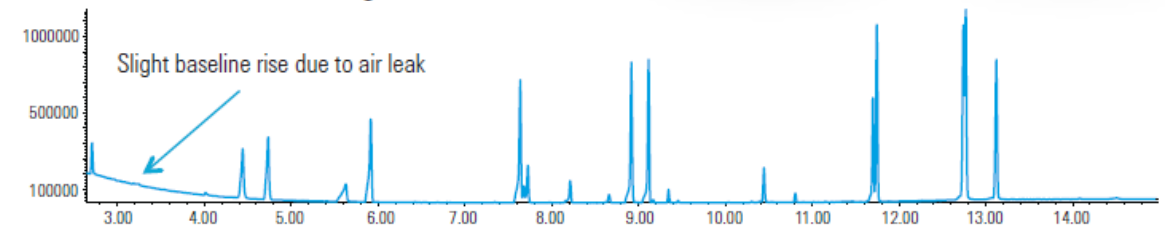

Standard column nuts after 25 injections

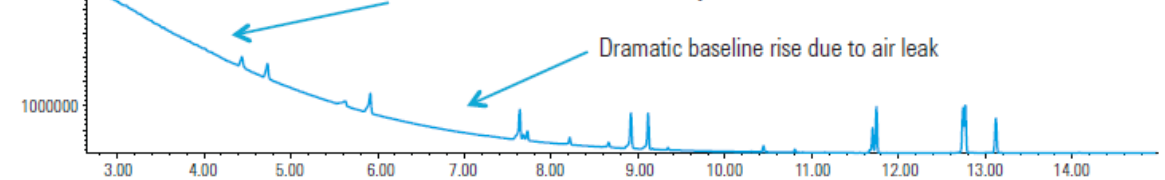

Agilent Self Tightening Column Nuts after 400 injections

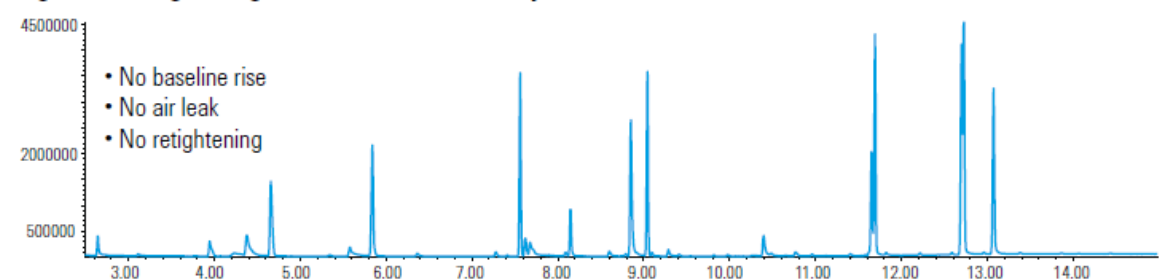

400 injections

New Agilent Standard Winged Nut and Depth Guide

- Compatible with Agilent/HP style compact ferrules, including graphite ferrules
- Winged fastener design for easy engagement and tool-free install
- Hollow-body design with low thermal mass mitigates thermal lag during temperature cycling within the GC oven
- Removable locking-collar with soft-PTFE insert to secure column placement during install, without damaging the analytical column

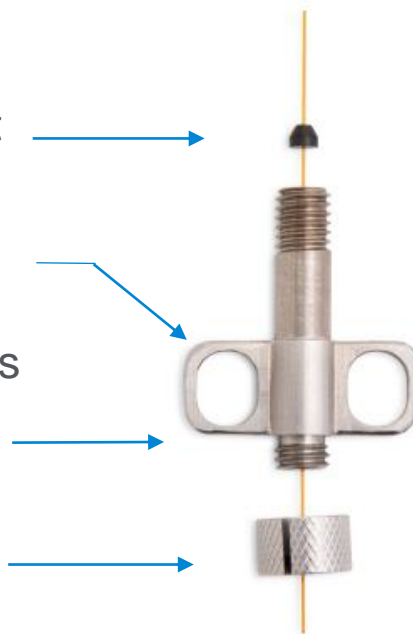

Don't confuse them with the Self-tightening nuts



Inlet/detector
G3440-81018









MSD
G3440-81019





- Easy-to-use template provides critical capillary column installation for the most popular Agilent GC configurations
 - SSL, MMI, purge-packed inlets
 - FID, TCD, NPD detectors
 - EI MSD source
- Compatible with the Agilent Self Tightening and winged column nuts



Matching the Correct Nut with the Correct Ferrule

<u>Nuts/ferrules for inlets and non-MS detectors (male)</u>			
Photo	Nut	Photo	Ferrule
	Traditional/ legacy nut		Short
	Wing nut		Short
	Self Tightening column nut		Short – G/V only

<u>Nuts/ferrules MSD (female – G/V only)</u>			
Photo	Nut	Photo	Ferrule (G/V Only!)
	Traditional/ legacy nut		Long
	Wing nut		Long
	Self Tightening column nut		Short – G/V only

How Long Will My Column Last?

- If you never use a column, it will last forever
- Lifetime is dependent on:
 - How dirty your sample is
 - Thermal damage?
 - Oxygen damage?
 - Physical damage?
 - How often you use **the column**
- Run **an** instrument blank and an injection of a clean standard to evaluate column performance
- Cut column to remove any nonvolatile contamination
- Bake out column to remove **semivolatile** contamination

Agilent J&W Column Portfolio – DB, HP, CP, VF

Low Polarity			Mid Polarity			High Polarity		
CP-Sil 2	DB and HP-1MS UI	DB and HP-5MS UI	DB-XLB	DB-225MS	DB-ALC1	HP-88	DB-WAX	DB-WAX UI
DB-MTBE	DB and HP1-MS	DB and HP5-MS	VF-XMS	DB-225	DB-Dioxin	CP-Sil 88	DB-WAX ETR	DB-HeavyWAX
CP-Select CB MTBE	VF-1MS	VF-5MS	DB-35MS UI	CP-Sil 43 CB	DB-200	DB-23	HP-INNOWax	DB-FATWAX UI
	DB and HP-1	DB and HP-5	DB and VF-35MS	VF-1701 MS	VF-200MS	VF-23 MS	VF-WAX MS	
	CP-Sil 5 CB	CP-Sil 8 CB	DB and HP-35	DB-1701	DB-210		CP-WAX 57 CB	
	Ultra 1	Ultra 2	DB and VF-17MS	CP-Sil 19 CB	DX-4		DB and HP-FFAP	
	DB-1HT	VF-DA	DB-17	HP-Blood Alcohol			DB-WAX FF	
	DB-2887	DB-5.625	HP-50+	DB-ALC2			CP-FFAP CB	
	DB-Petro/PONA	DB and VF-5HT	DB-17HT	DX-1			CP-WAX 58 FFAP CB	
	CP-Sil PONA CB	CP-Sil PAH CB	DB-608				CP-WAX 52 CB	
	DB-HT SimDis	Select Biodiesel	DB-TPH				CP-WAX 51	
	CP-SimDis	SE-54	DB-502.2				CP-Carbowax 400	
	CP-Volamine		HP-VOC				Carbowax 20M	
	Select Mineral Oil		DB-VRX				HP-20M	
	HP-101		DB-624				CAM	
	SE-30		VF-624MS				CP-TCEP	
			CP-Select 624 CB					
			DB-1301					
			VF-1301MS					
			CP-Sil 13 CB					

Agilent J&W columns have over 50 different stationary phase offerings

Example of Column Contamination and Broad Peaks

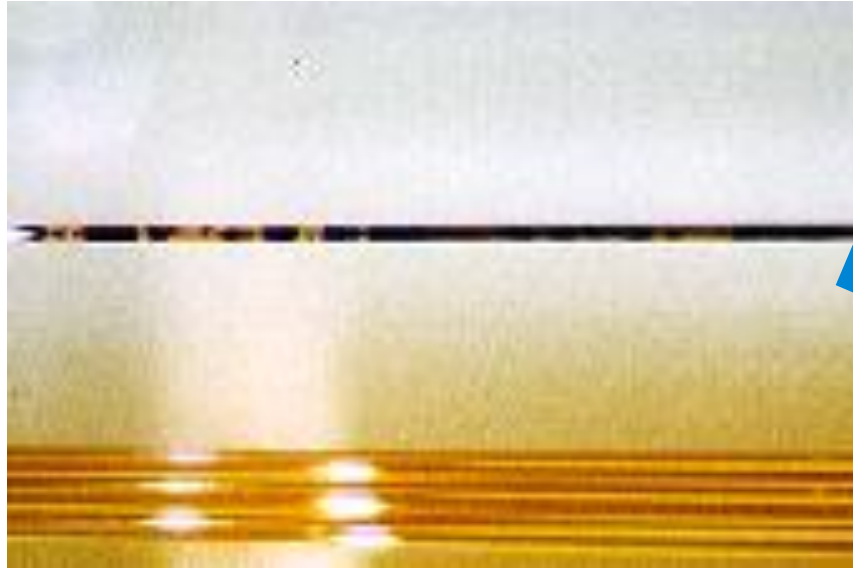
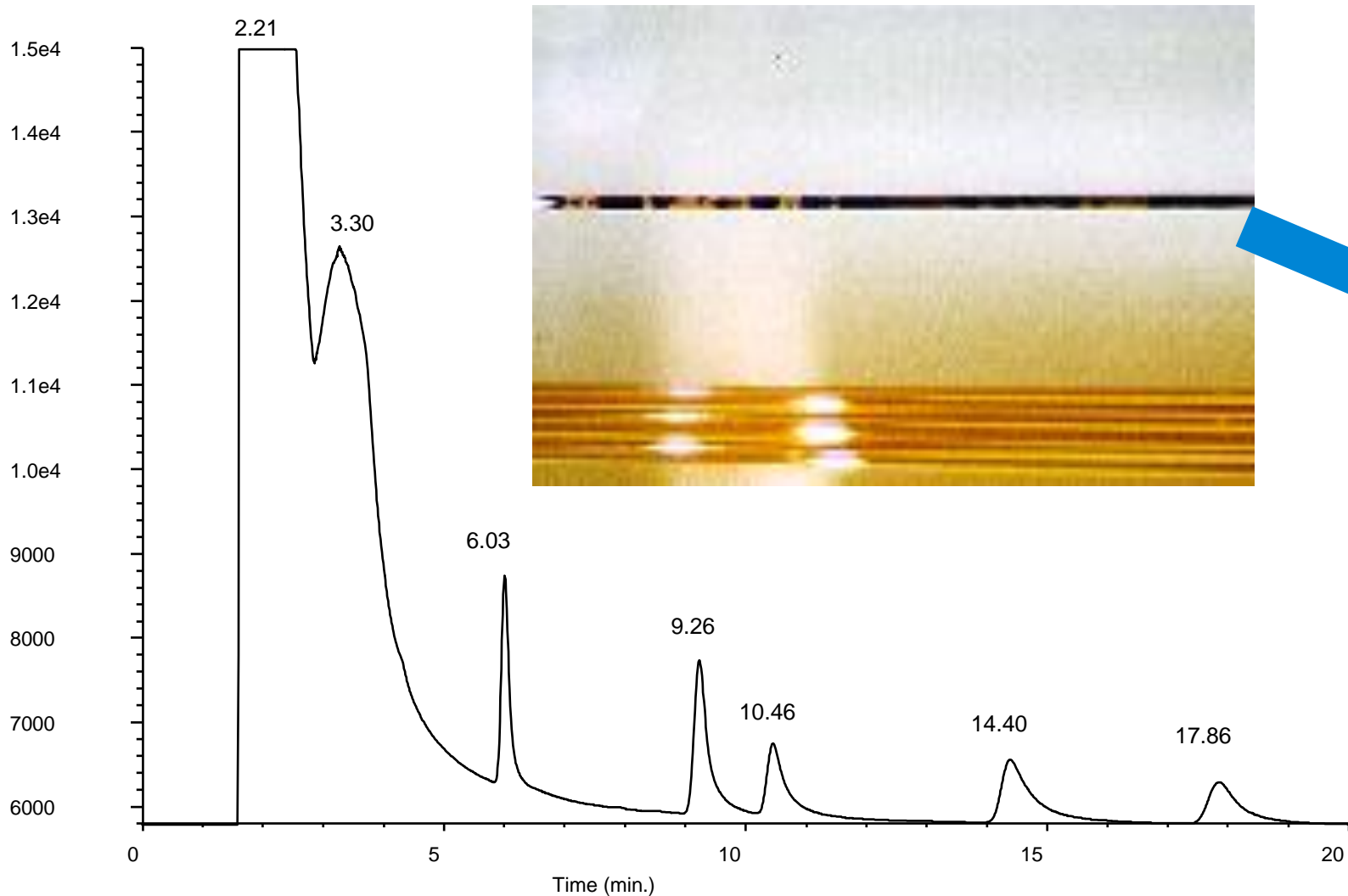

Agilent J&W DB-624 QC test mix
After 75 injections of oily sample

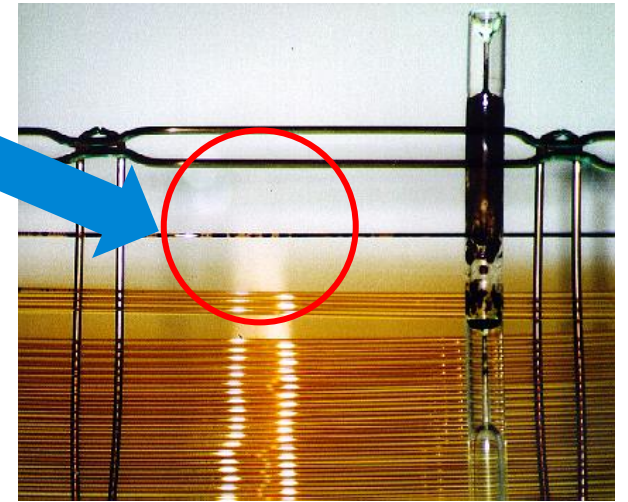

*Temperature program: 35 °C hold 1.5 min // 30 °C/min to 65 °C, hold 10 min

Cutting the Column

Gently scribe through the polyimide coating

- Do not attempt to cut the glass

Recommended tools

- Diamond or carbide-tipped pencil, or sapphire cleaving tool
- Ceramic wafer
- Ocular

Do not use

- Scissors, file, and so on

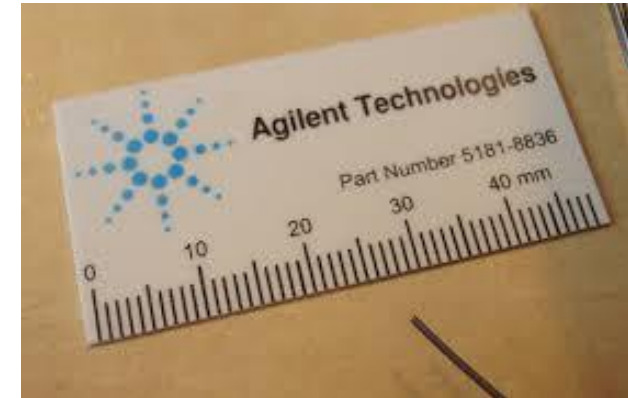

Physical Damage to the Polyimide Coating

- The smaller the tubing diameter, the more flexible it is
- Avoid scratches and abrasions
- Immediate breakage does not always occur upon physical damage

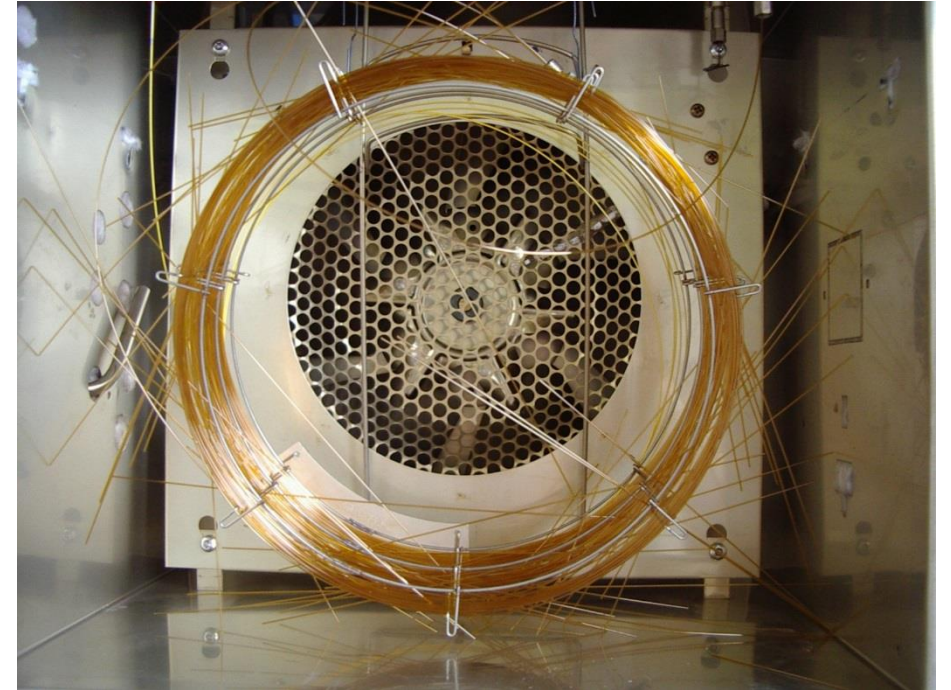

Thermal Damage

Degradation of the stationary phase is increased at higher temperatures

- Rapid degradation of the stationary phase (breakage along the polymer backbone) **can be** caused by excessively high temperatures

Isothermal limit = indefinite time

Programmed limit = 5 **to** 10 minutes

- Temporary "column failure" below lower temperature limit
- If this happens:
 - Disconnect column from detector
 - "Bake out" overnight at isothermal limit
 - Remove 10 **to** 15 cm from **the** column end

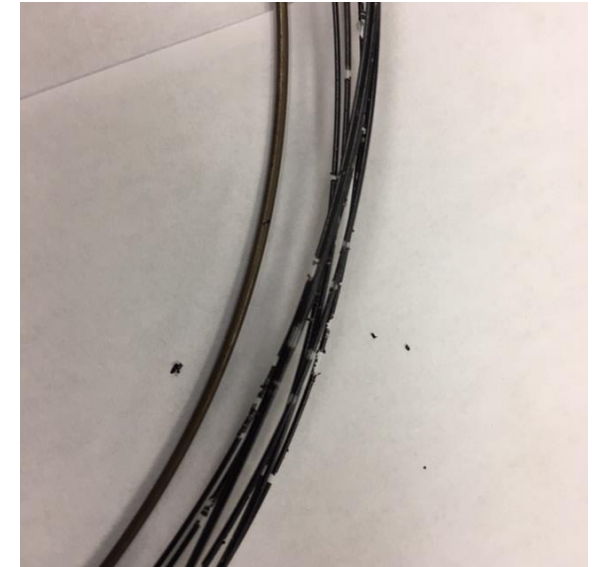

Column continuously exposed to temperatures above its temperature limit

Oxidation (O₂ Damage)

Oxygen in the carrier gas rapidly degrades the stationary phase. The damage is accelerated at higher temperatures. Damage along the polymer backbone is irreversible. (Premature filament failure/excessive source maintenance.)

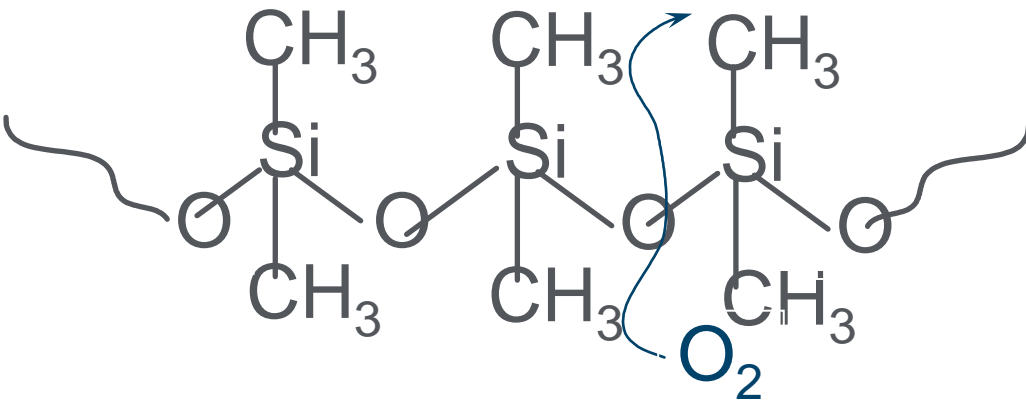

Dimethylpolysiloxane

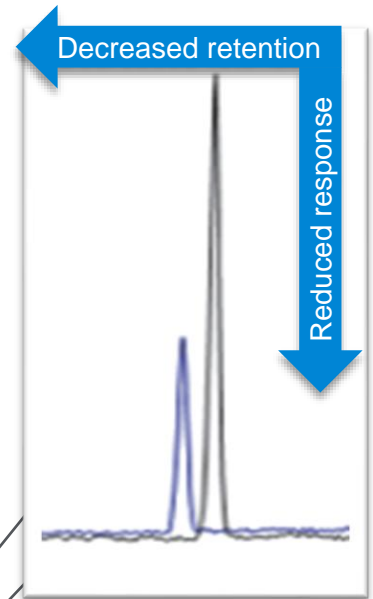
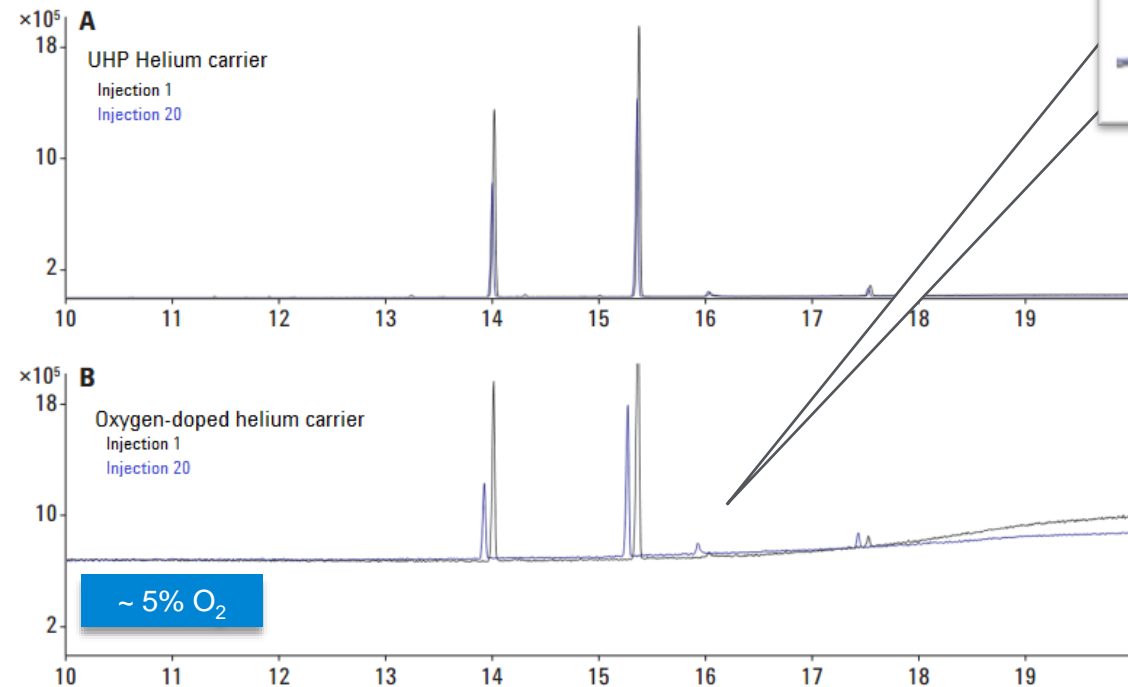

Guard Column or Retention Gap

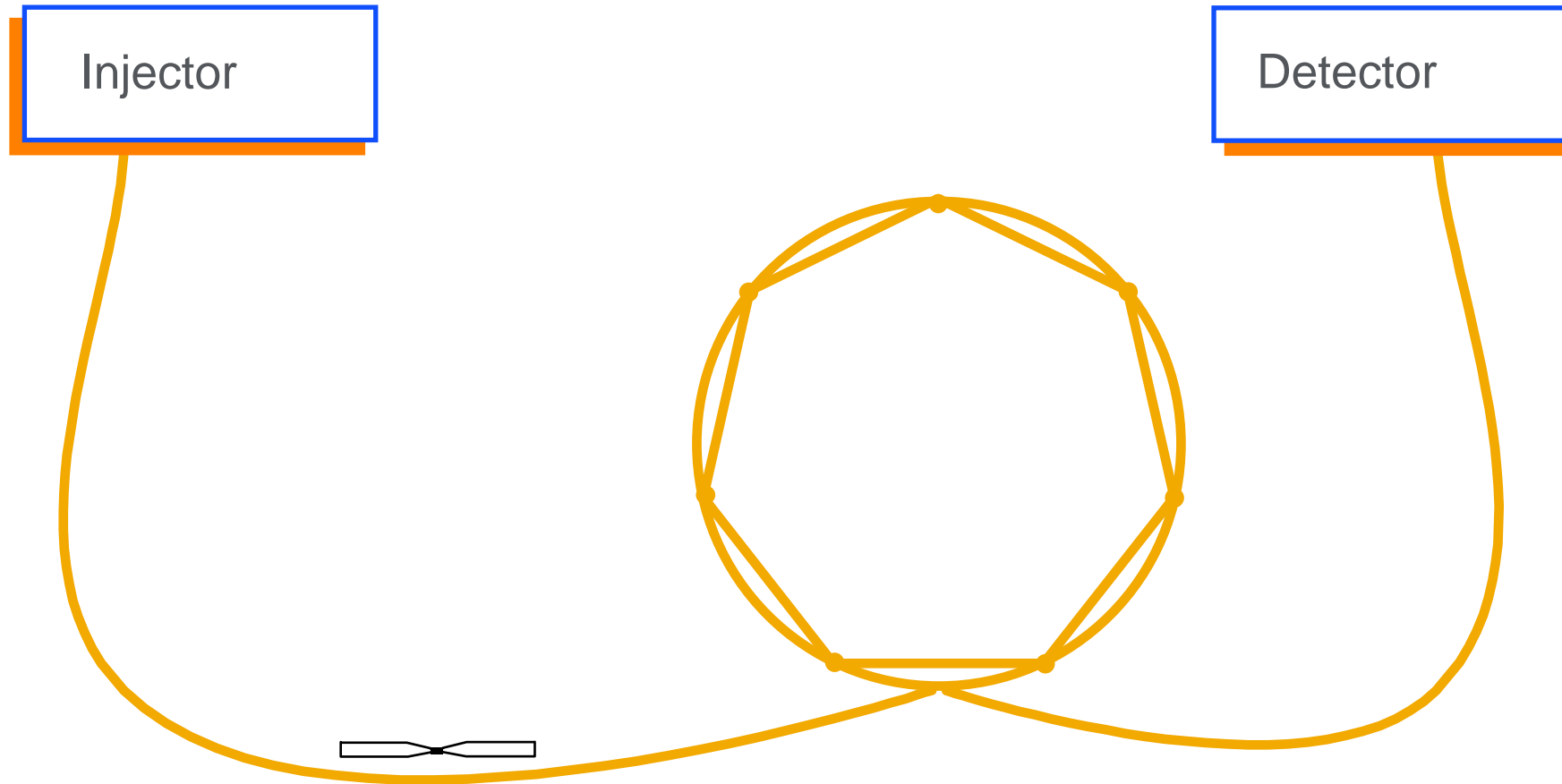

The guard column is 3 to 5 m of deactivated fused silica tubing with the same diameter as the analytical column. It is connected with a zero dead volume union.

Agilent CrossLab CS (Cartridge System)

No peaks from leaks

Features:

- Exchangeable cartridge with an ADM Flow Meter
- Automatic notification of probe filter replacement
- Ergonomic and robust design
- Universal 3AA or USB power
- USB connects to web interface for added functionality and firmware updates
- Easy-to-view OLED screen
- Kickstand

Leak detector
cartridge

Handheld



ADM Flow Meter
cartridge

The Cost of Leaks

Cost of gases

Contamination from exposure

Reduced consumable lifetime

Reduced productivity from downtime

Detector noise and elevated baselines

Time in troubleshooting



It is critical that every customer checks for leaks. They should have the best tool for the job. Check valves, fittings, and traps for leaks after every maintenance, and after thermal cycling, as these can loosen some types of fittings.

Ordering Guide

G6693A – CrossLab CS Electronic Leak Detector

G6694A – Electronic Leak Detector cartridge

G6699A - CrossLab CS bundle: ADM Flow Meter and Electronic Leak Detector

- The bundle will include one handheld, two cartridges, and a free carrying case.

G6694-60005 – Replacement probe filter

G6691-40500– Carrying case



Existing products:

G6691A – CrossLab CS ADM Flow Meter

G6692A – ADM Flow Meter cartridge*

- Note that the ADM Flow Meter cartridge is ordered annually for calibration. The Electronic Leak Detector does not need to be recalibrated.

Better Connections: Ultra Inert Press Fits or Ultimate Union

Ultra-inert press fits:

- Join retention gap or guard column to analytical column
- Dependable inertness performance at a lower cost
- Batch certified inertness
- Improved packaging and installation instructions
- Easier to use – transparent deactivation gives visibility of the column connection

Ultimate union

- More robust
- Reusable
- Recommended for users with MS



Integrated Guards – DuraGuard

- No union
- Possible for any DB column 0.18 mm and larger
- Limited offering “off-the-shelf”

DuraGuard

Phase	ID (mm)	Length (m)	Film (µm)	Guard Length (m)	Part No.	
DB-1	0.25	30	0.25	10	122-1032G	
DB-XLB	0.25	30	0.25	10	122-1232G	
DB-5ms	0.25	30	0.25	10	122-5532G	
			0.50	10	122-5536G	
			1.00	10	122-5533G	
		60	0.25	10	122-5562G	
		0.32	30	1.00	10	123-5533G
		0.53	30	0.50	10	125-5537G
DB-5.625	0.18	20	0.36	5	121-5622G5	
	0.25	30	0.25	5	122-5631G5	
DB-1701	0.53	30	1.00	10	125-0732G	
DB-624	0.53	30	3.00	5	125-1334G5	

Introducing the Agilent 8890 GC System

Flexible and expandable to meet your needs today and tomorrow



Future-proof: Ready for anything

- Powerful, next-generation electronic architecture
- Expanded smart-connected functionality
- Full suite of inlets, detectors, and accessories, CFT, Deans switch, backflush, GC x GC, dual simultaneous injection
- Six valves, eight heated zones, plus LVO
- Generation 6 precision EPC
- Smart keys
- 7-inch color touch display



Agilent 8890 GC System

Smart-connected GC

Modern intuitive interface

7-inch color touch screen

- Configuration
- Status
- Methods
- Sequence info
- Troubleshooting, diagnostics, and help

Real-time chromatographic evaluation

- Blank evaluation
- Detector evaluation

GC Columns with Smart Key (for the Agilent 8890 GC only)

For immediate identification and usage monitoring of your GC column

- Available with the Agilent 8890 GC only
- Can track the use of a GC column
- Smart key contains GC column information, including:
 - Part and serial numbers
 - Number of injections/runs
 - Time at/above temperature limits
 - Date installed
 - Temperature limits – GC columns
 - If more than one column is installed, the temperature is determined by lowest column smart key installed (DB-WAX vs DB-5)
 - Column length/trimming is done in “column maintenance mode” in the software and rewritten to the smart key
 - S/N ratio of last instrument installed if it was in an 8890 GC



GC Columns with Smart Key

Feature, advantages, and benefits

Feature	Advantage	Benefit	Economic Benefit
<p>Smart key included with the GC column (p/n must include "KEY")</p> <p>Designation example *122-5532UI-KEY*</p>	<ol style="list-style-type: none"> Reduce possible errors from manual input of method parameters Optimize maintenance schedules with usage tracking 	<ol style="list-style-type: none"> Better data quality as the system is aware of the configuration Ease-of use Ability to better plan preventive maintenance before issues occur 	<ol style="list-style-type: none"> Ease-of-use, no risk of faulty information in the GC, fewer reruns Limited downtime as preventive maintenance is easier to plan

	Literature	Web Page
1	Agilent 8890 GC brochure	https://www.agilent.com/cs/library/brochures/brochure-gc-8890-5994-0476en-agilent.pdf
2	Smart key product page (not for ordering smart keys)	www.Agilent.com/chem/smartkey8890
3	Instruction sheet	https://www.agilent.com/cs/library/instructionsheet/public/insert-smart%20key-8890-5994-0700en-agilent.pdf

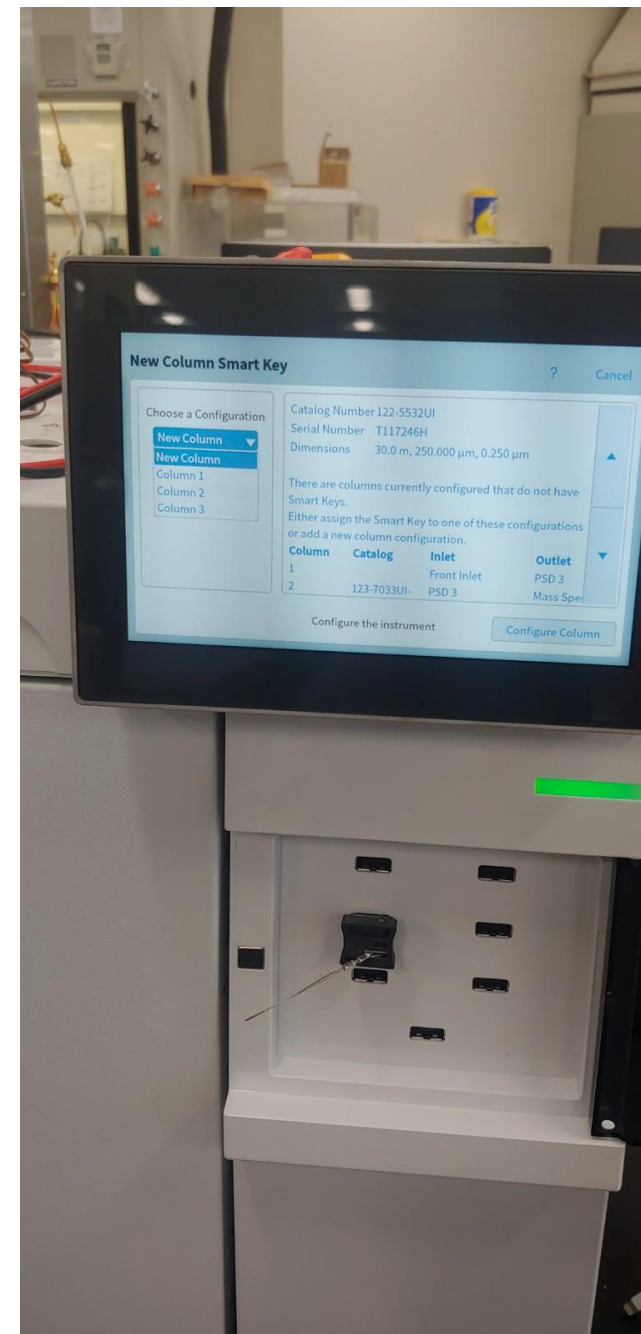

GC Columns with Smart Key

Smart key clarifications

- It is not a USB flash drive. It comes preprogrammed from the factory with specific information about the GC column it belongs to.
- It is not tethered to the GC column, neither is it connected through Wi-Fi or Bluetooth.

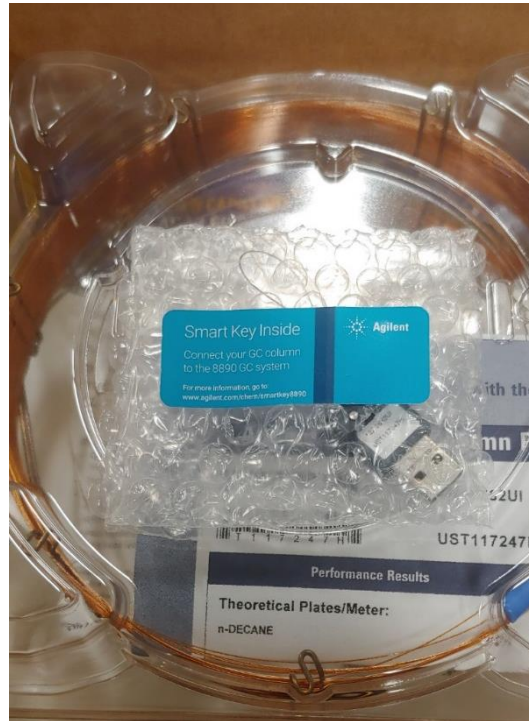

New Agilent Universal Fit GC Detector Jets

- Easier column installation and jet replacement, reducing the risk of column damage
- Lubricant-free threads, reducing the risk of contamination
- Made from strong material, reducing the risk of deforming
- Universal – fits in both capillary column and packed column (adaptable) FID detectors







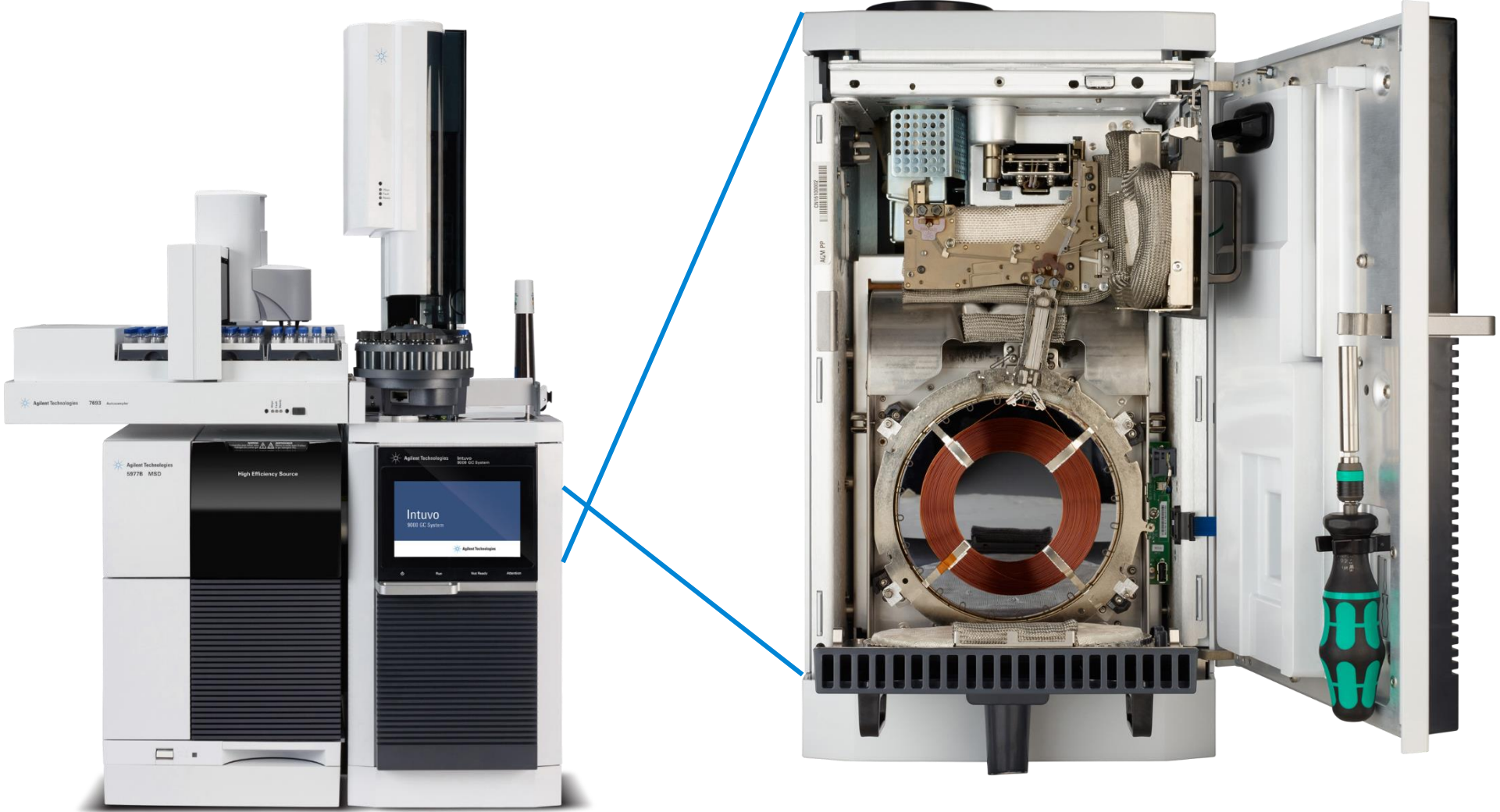

Previous Jets				New Universal Fit Jets			
Previous Jet PN	Jet Orifice ID (inch/mm)	Jet Length (inch/mm)	Fit of Detector Fitting Type	New Jet PN (use for re-order)	Jet Orifice ID (inch/mm)	Jet Length (inch/mm)	Fit of Detector Fitting Type
19244-80560	0.011 / 0.29	2.4 / 62	FID, Adaptable	5200-0176	0.011 / 0.29	1.2 / 31	FID, Capillary & Adaptable
G1531-80560	0.011 / 0.29	1.7 / 43	FID, Capillary				
18710-20119	0.018 / 0.47	2.5 / 64	FID, Adaptable	5200-0177	0.018 / 0.47	1.2 / 31	FID, Capillary & Adaptable
19244-80620	0.018 / 0.47	2.4 / 62	FID, Adaptable				
G1531-80620	0.018 / 0.47	1.7 / 43	FID, Capillary				
18789-80070	0.030 / 0.76	2.5 / 64	FID, Adaptable	5200-0178	0.030 / 0.76	1.2 / 31	FID, Capillary & Adaptable
G1534-80580	0.011 / 0.29	2.0 / 52	NPD, Capillary	5200-0179	0.011 / 0.29	1.6 / 40	NPD, Capillary & Adaptable
G1534-80590	0.011 / 0.29	2.8 / 71	NPD, Adaptable				

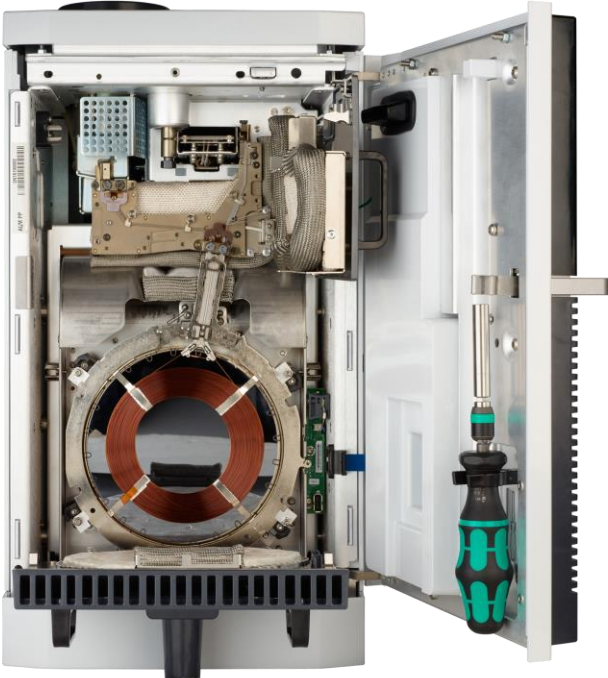
Agilent Intuvo 9000 GC System



GC Flow Path Comparison

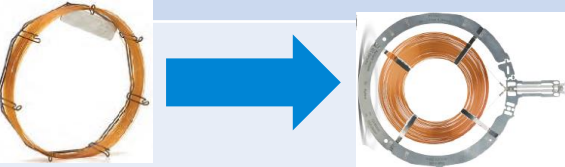

Consumable	5890 / 6890 / 7820 / 7890 / 8860 / 8890	Intuvo 9000	When to Change?	
Septum →	Same	Same	As needed	
Liner →	Same	Same	As needed	
Ferrules →	Graphite / Graphite-Vespel	Gaskets	Single use with column installation	
Gold seal →	Standard or UI	Guard Chip	As needed	
Guard Column / Column trim	Fused silica	Guard Chip	As needed	
Column	Standard 7 in cage	Unique	As needed	

How Can I Get More Lifetime Out of My Liners, Gold Seals, and Columns?

How did it become contaminated in the first place?

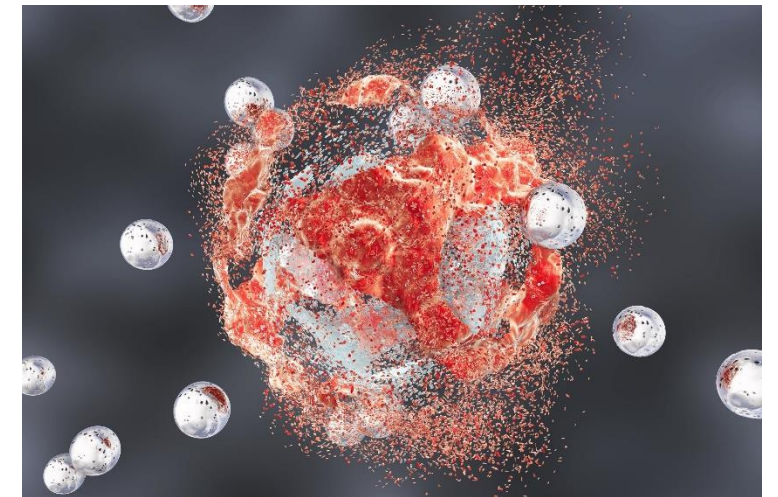

The Matrix

If your target ions are buried beneath matrix peaks, it might be time to trim the column or do sample cleanup

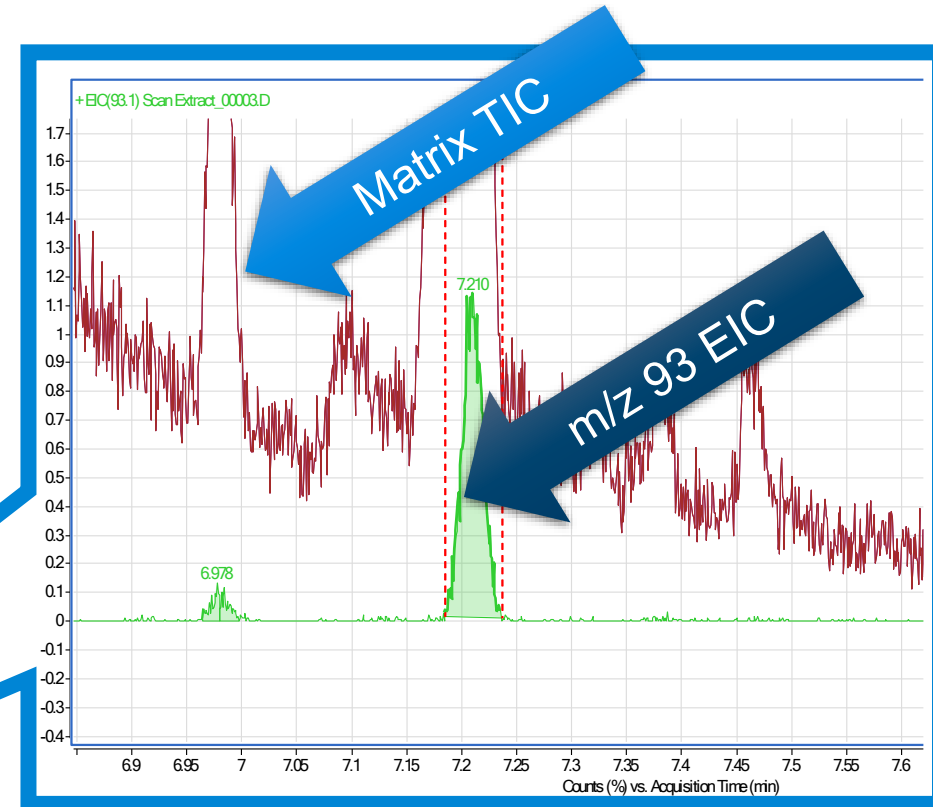
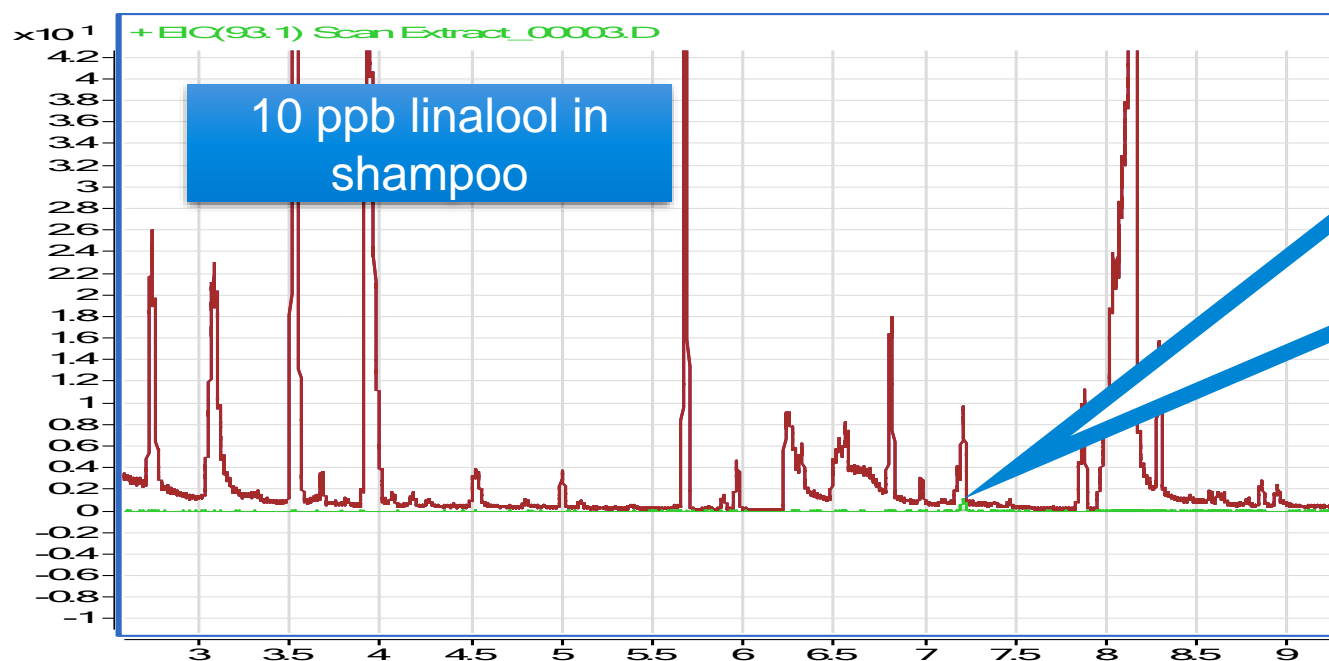

(Or improve your sample cleanup)

The Importance of Sample Cleanup

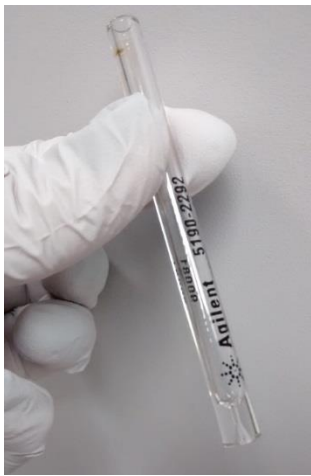

50 samples
with cleanup

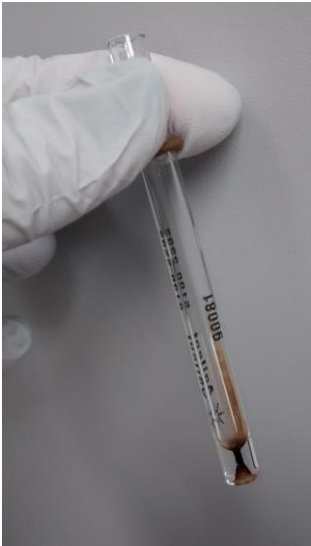

50 samples
without cleanup

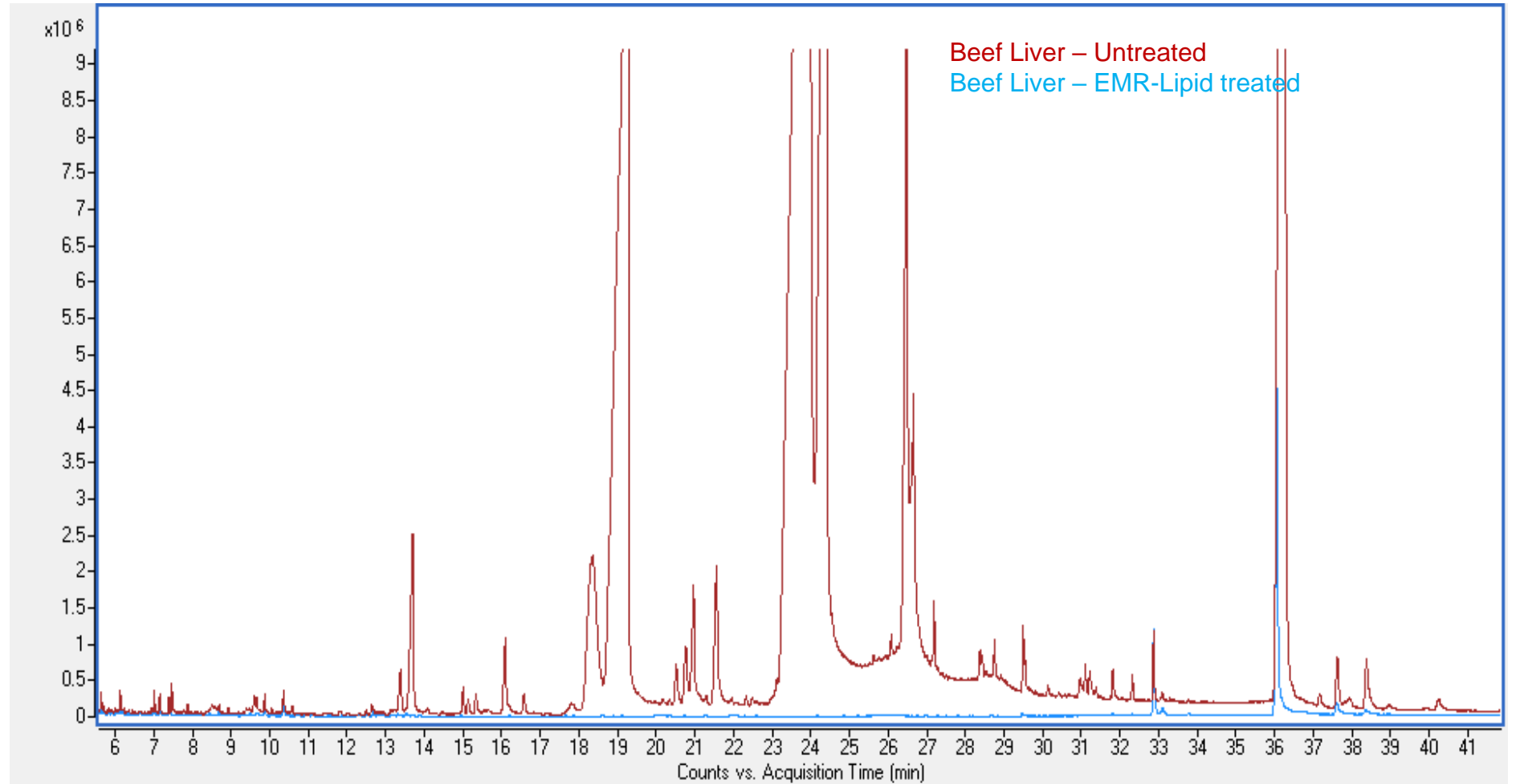

For sample cleanup help, please contact us at spp-support@agilent.com.

Determination of 19 Polycyclic Aromatic Hydrocarbon Compounds in Salmon and Beef

Using Captiva EMR-Lipid cleanup by GC/MS/MS

Salmon dried residue

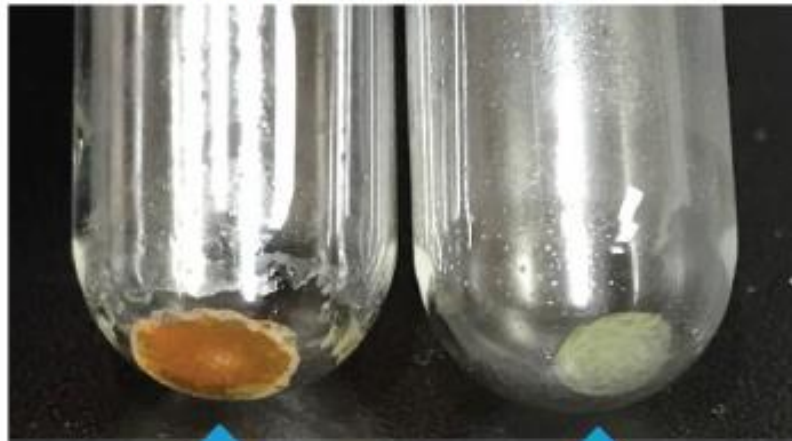

No cleanup

Captiva EMR-Lipid
cleanup

Beef dried residue

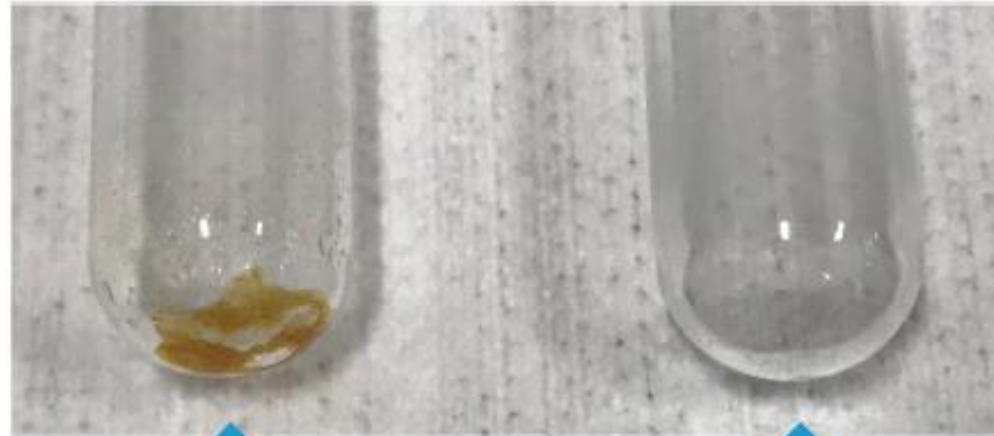

No cleanup

Captiva EMR-Lipid
cleanup

5994-0553EN

Captiva EMR-Lipid Cleanup Improves Analyte S/N Ratio and Integration Accuracy on GC/MS(/MS)

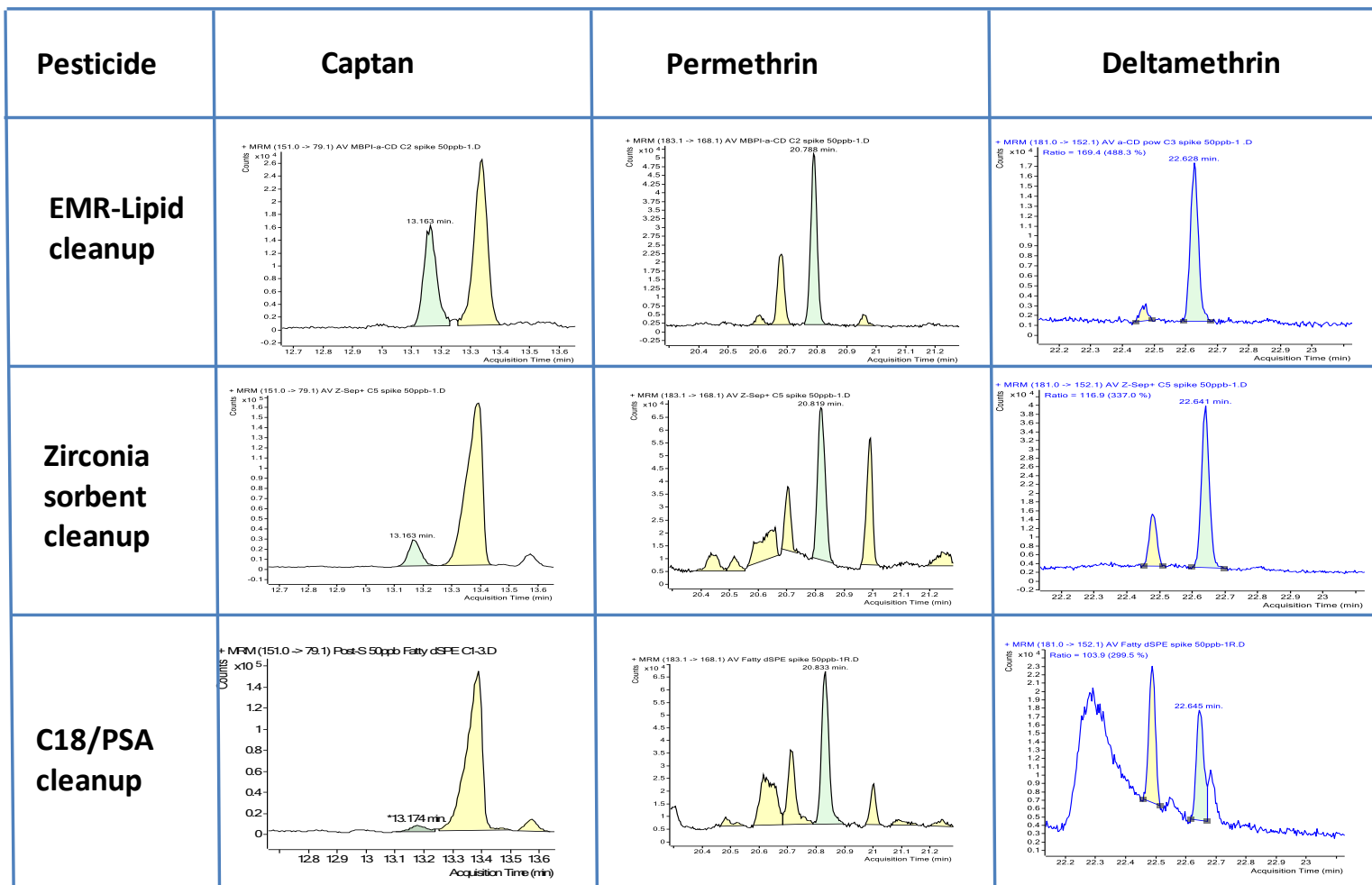

5994-0405EN

Offline Options for Sample Matrix Removal

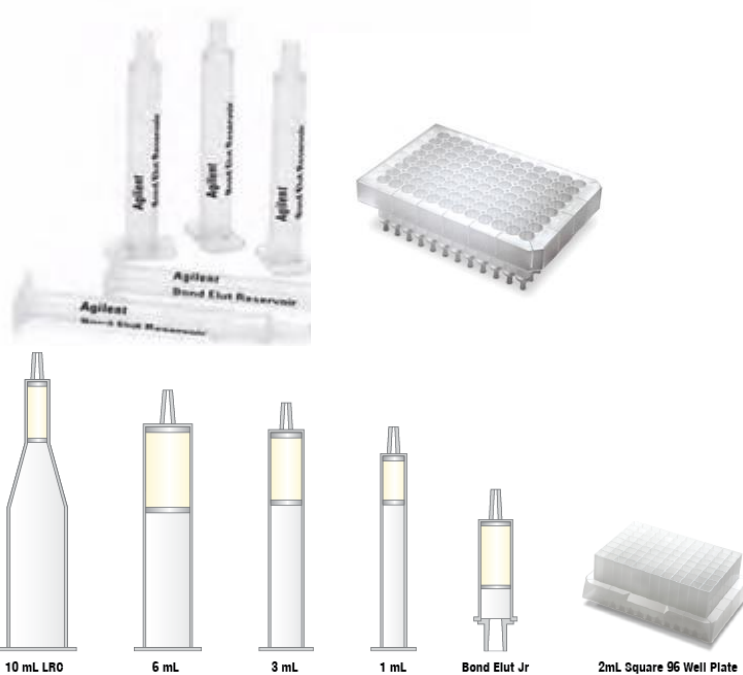

QuEChERS



Captiva EMR-Lipid filtration cartridges and plates

Bond Elut Solid Phase Extraction cartridges and plates



Filter vials



Captiva syringe filters



Synthetic Chem Elut S

When Do I Change Specific Parts?

Item	Typical Schedule	Comments
Septum Nut	3-6 months	Septum nut can get worn and shed metal particle into the liner. Replace to minimize activity in the inlet/liner.
Syringe	Every 3 months	Check movement of plunger and replace if it does not move freely and cannot be cleaned.
Gold Seal	Monthly	At a minimum replace when trimming the front end of the column
Split Vent Trap	6 months-1 year	Often forgotten. Can also cause retention instability.
Liner	Weekly	The liner takes the brunt of the sample load/residues. Replace often to help prevent unwanted down time.
Trim/Replace column	Weekly-Monthly	When experiencing chromatographic problems trim ½ to 1 meter of the front end of the column. Replace liner, septum and gold seal.
Inlet Setpa	100-200 injections	Depends a bit on septum type and manual/auto injections.

Schedule is an approximation of average usage requirements. Actual frequency is application and sample specific. Use your chromatography as a guide to developing a normal maintenance schedule.

Agilent University

Why training? What can we help with?

Agilent University:

- Trained over 38K students in 2019
- 98% customers recommend
- 4.6 out of 5 for customer satisfaction
- 94% excellent and very good

Labs who want faster and more efficient learning options to help overcome training challenges

Overtasked staff

Staff turnover

Pressure to improve quality and productivity

Daily consistency with output and results

Reduce costs associated with lab operations

Flexible and convenient training options when and where you need them

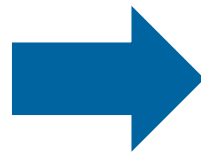

Virtual training



Virtual instructor led



eLearning self-paced

In-person training



Classroom



On-site or virtual on-site

Trust Agilent for answers with up-to-date knowledge and generally accepted practices for all your training needs

Contact Agilent Chemistries and Supplies Technical Support



1-800-227-9770 option 3, option 3:

[Option 1 for GC and GC/MS columns and supplies](#)

Option 2 for LC and LC/MS columns and supplies

Option 3 for sample preparation, filtration, and QuEChERS

Option 4 for spectroscopy supplies

Option 5 for chemical standards

Available in the U.S. and Canada, 8–5, all time zones



gc-column-support@agilent.com

lc-column-support@agilent.com

spp-support@agilent.com

spectro-supplies-support@agilent.com

chem-standards-support@agilent.com