

# Demystifying Valve Gas Chromatography



## Understanding GC Rotary Valve Modes of Operation and Application

Shannon Coleman  
Application Scientists  
and  
Kelly Beard  
Application Scientists  
Agilent Technologies

# Section 1: Understanding Valves

The goal of this presentation is to provide a basic understanding about GC valves, valve diagrams, and how valves work to the benefit of the chromatographer. We will start with the basics and work our way up in complexity. In this section, we will discuss GC valves, the mechanics of how they work and how this is depicted in a valve diagram.

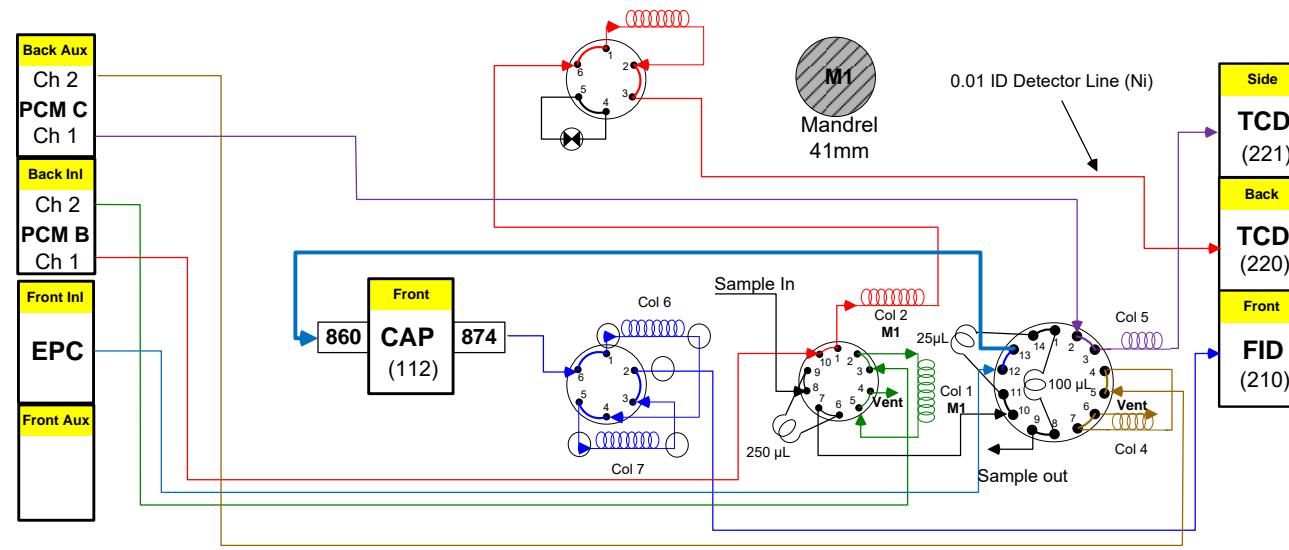

# What is Valve Gas Chromatography?

The loose definition is: when valves are used with GC to select a specific sample for injection, inject a sample, or change the flow direction of sample.

Let's jump right into learning the basics of valves...



# Commonly Used GC Valves

There are only a few different types of commonly used valves in chromatography, but the number of possible configurations can seem infinite.

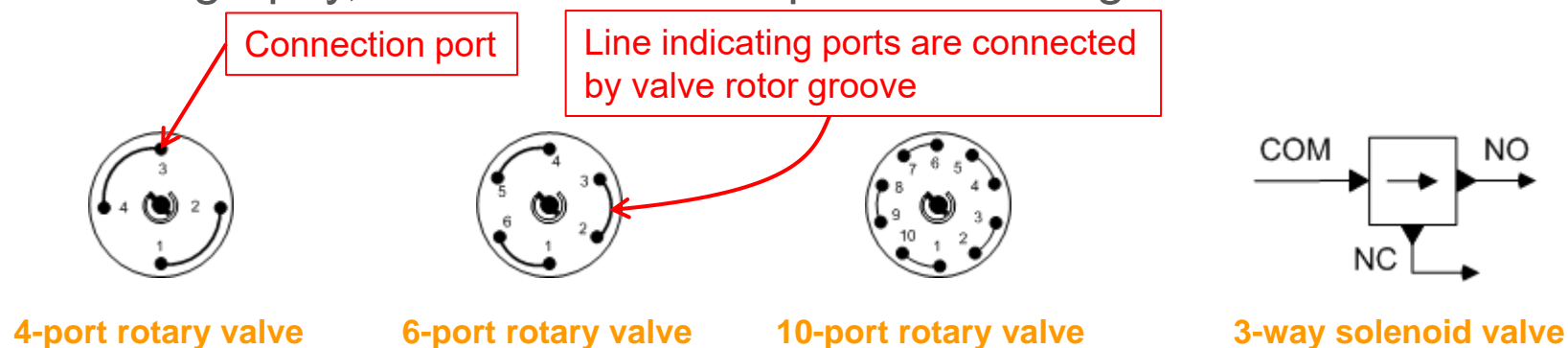

The valve drawings above represent how valves are normally depicted on a plumbing diagram. The numbered dots on the valves indicate a port; a location where tubing or columns are connected. The lines connecting the ports on the diagram indicate which ports are connected by the valve rotor groove when the valve is in the de-energized (**OFF**) position. It's important to remember valves are always drawn in the (**OFF**) position.

# Diagram Correlation to Physical Valve

The port numbers on the physical valve are numbered. These port numbers correlate to the port positions on the valve diagram.

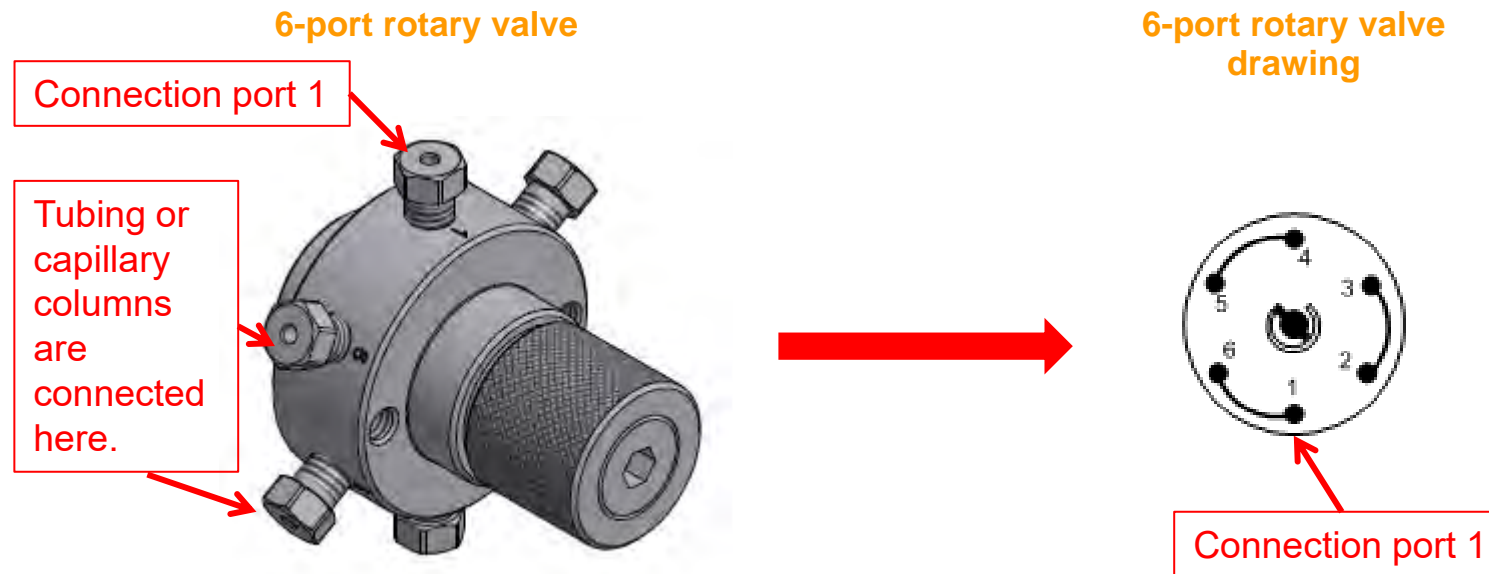

Note: By looking at the actual valve, it is very difficult to tell if the valve is “ON” or “OFF”. We use a drawing to understand the valve better and which ports are connected by the valve rotor.

# Valve Assembly

When the valve is disassembled you can see five major components to the valve; socket adjustment screw, preload assembly, rotor, body, and driver (not shown).

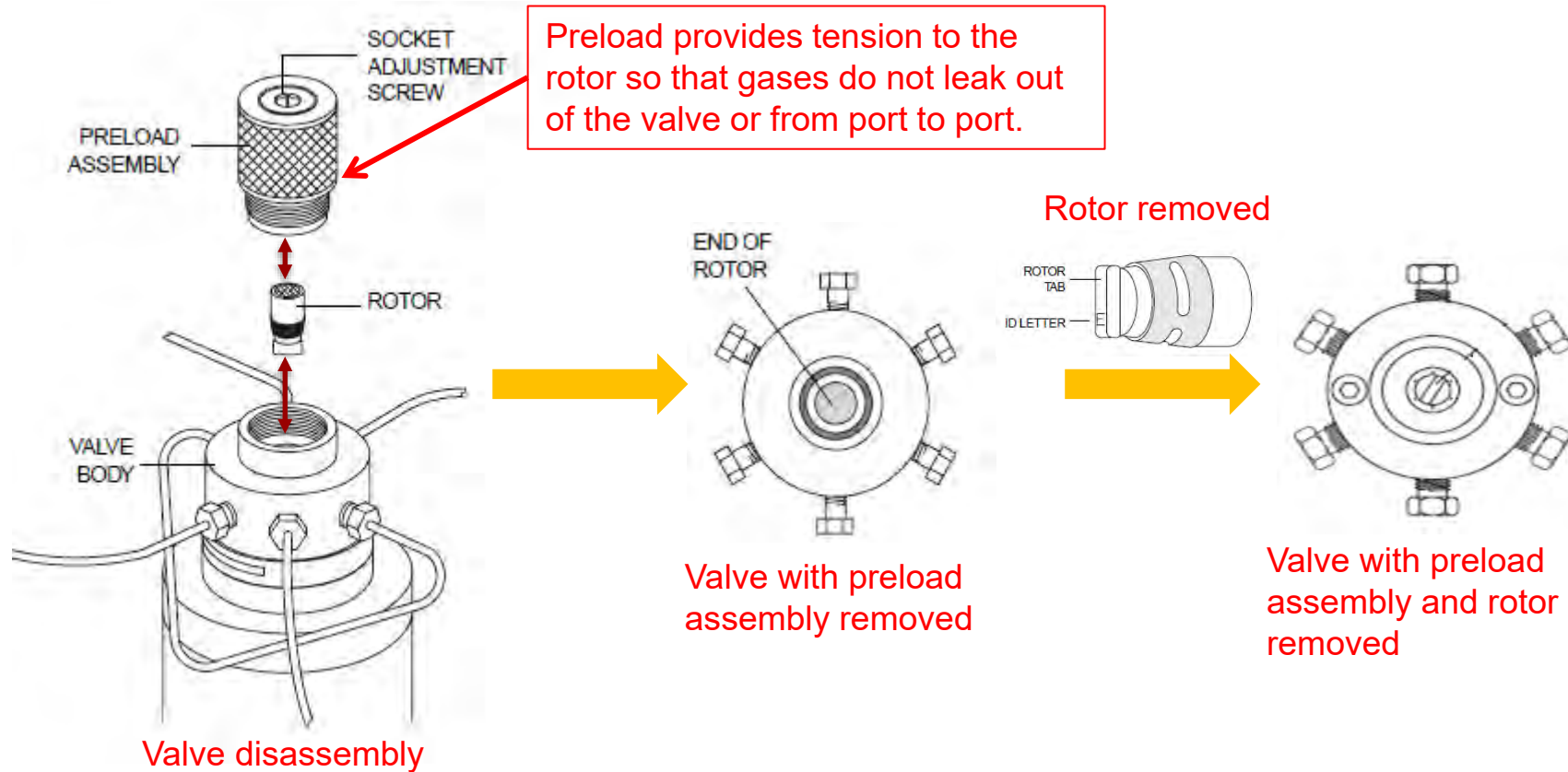

\*Valve renderings from [www.vici.com](http://www.vici.com)

# Valve and Valve Rotor Detail

A rotor groove connects two ports on a valve. A 6-port valve has three rotor grooves, a 10-port valve has five rotor grooves.

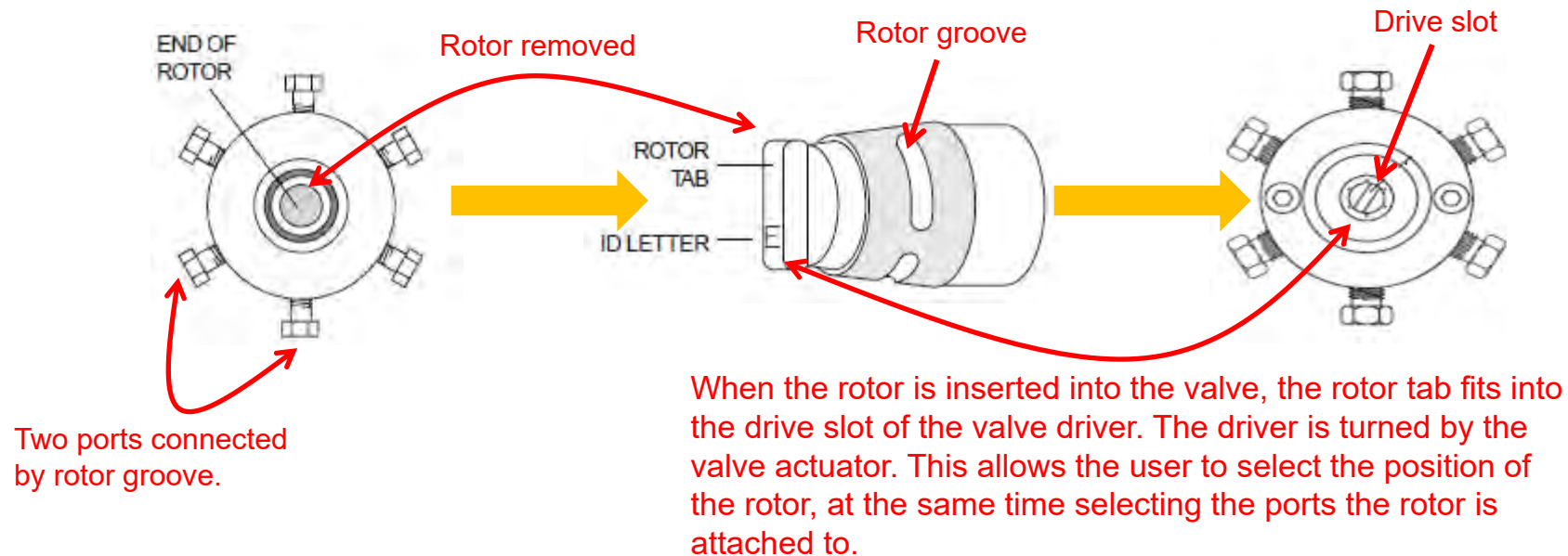

Once the valve rotor is removed from the valve body you can see how the gases flow from port to port through the rotor grooves. Each groove in the rotor connects two ports on the valve.

\*Valve renderings from [www.vici.com](http://www.vici.com)

# The Valve Rotor

The rotor grooves are machined into a soft polymer material that allows the grooves to be sealed in the valve. This prevents gases from leaking into the valve and from leaking from port to port.

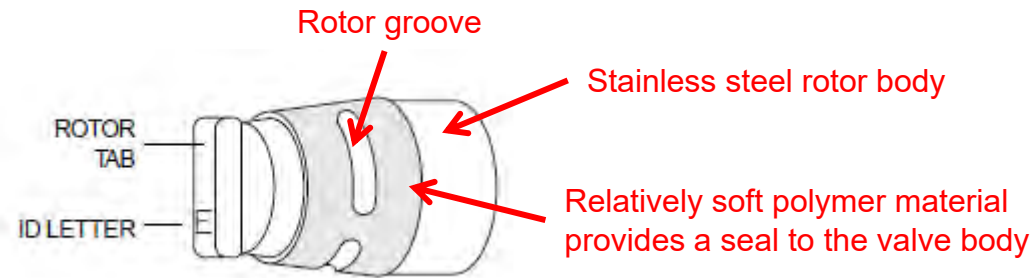

The ID letter on the rotor tab indicates what type of polymer is used to seal the valve rotor in the valve.

- Valcon E: Standard widely used rotor material, polyaryletherketone/PTFE composite, rating 400 psi at 225 °C.
- Valcon P: PTFE and Carbon composite, rating 1000 psi at 75 °C
- Valcon T: polyimide/PTFE/carbon composite, 300 psi at 330 °C, optimal temperature range of 250 °C to 350 °C.

These are the most frequently used rotors you will see in GC, with E being the most versatile and most widely used.

\*Valve renderings from [www.vici.com](http://www.vici.com)



# How the Actual Valve Relates to the Valve Diagram:

Now that you understand how the valve is designed, you can understand how the actual valve relates to the valve drawing on the diagram.

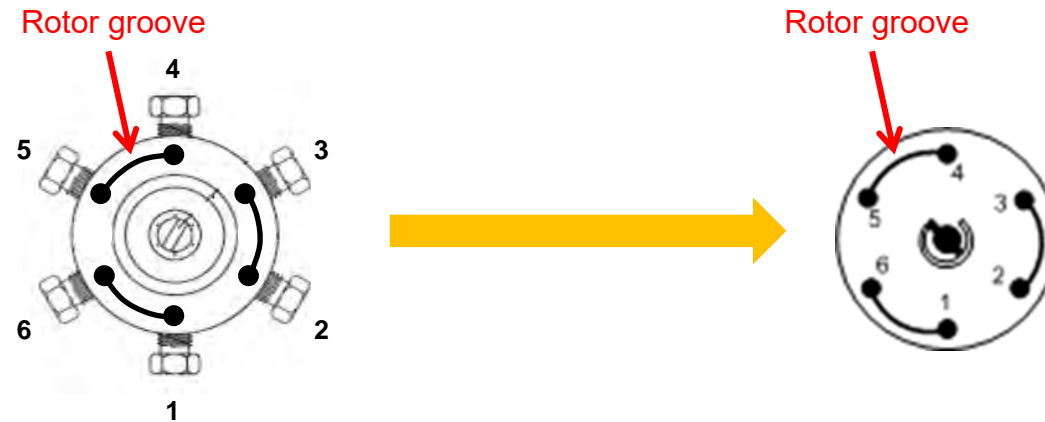

The actual rotor grooves in the valve are indicated by the lines on the valve diagram. This shows how the rotor is positioned in the valve in the “OFF” position and which valve ports are connected by the rotor grooves.

# How Are 6-port Valves Used in Gas Chromatography

In this section we will discuss the most common 6-port valve configurations and how they are used in chromatography.

There are a multitude of ways to configure a valve so we will start simple and work up in complexity, explaining how the most common configurations of the 6-port valve are used.



6-port rotary valve

# Common 6-port Valve Configurations

Including option numbers used to order configured on a G3540B  
8890B GC

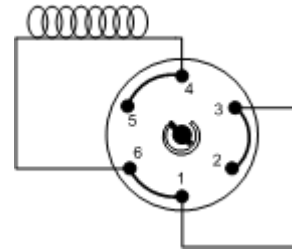
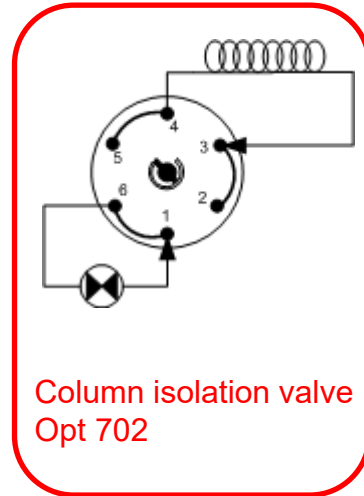
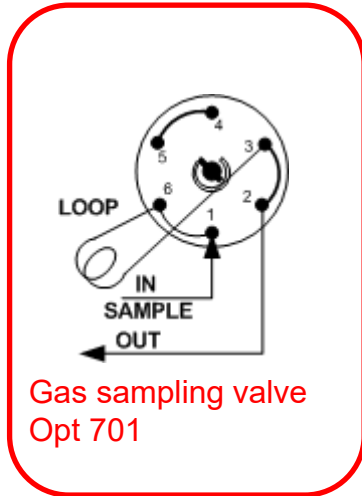

Backflush to detector  
Opt 704

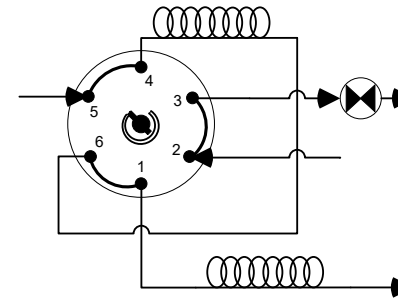

Backflush precolumn to vent  
Opt 705

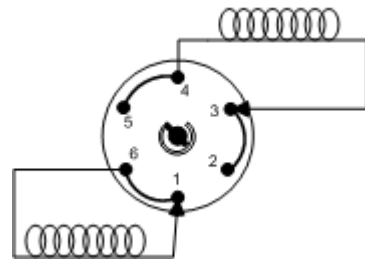

Column selection  
Opt 706

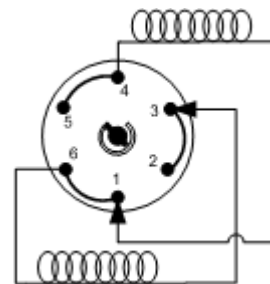

Sequence reversal  
Opt 707

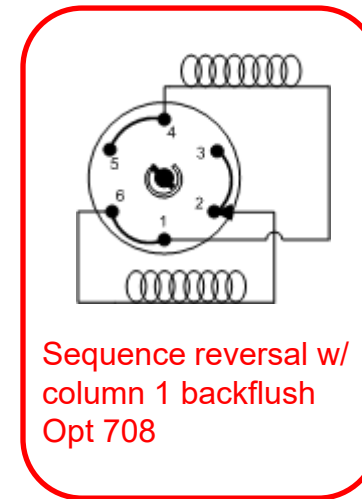

Sequence reversal w/  
column 1 backflush  
Opt 708

# 6-port Gas Sample Valve (GSV), G3540B, Opt 701

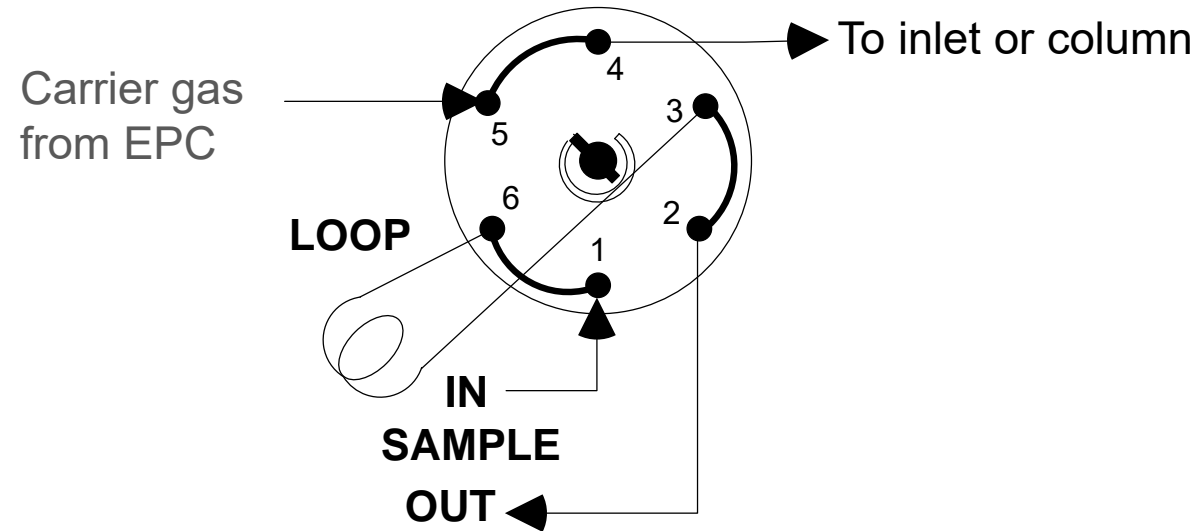

- Provides a method of injecting a fixed volume of gas into a GC inlet or directly onto a column.
- The loop can be filled using a syringe, a pressurized gas sample container, or connected directly to a process stream in some cases.
- It is important to know the sample volume the customer has available as well as the pressure of the sample.

# 6-port Gas Sample Valve (GSV), G3540B, Opt 701

## Sample load

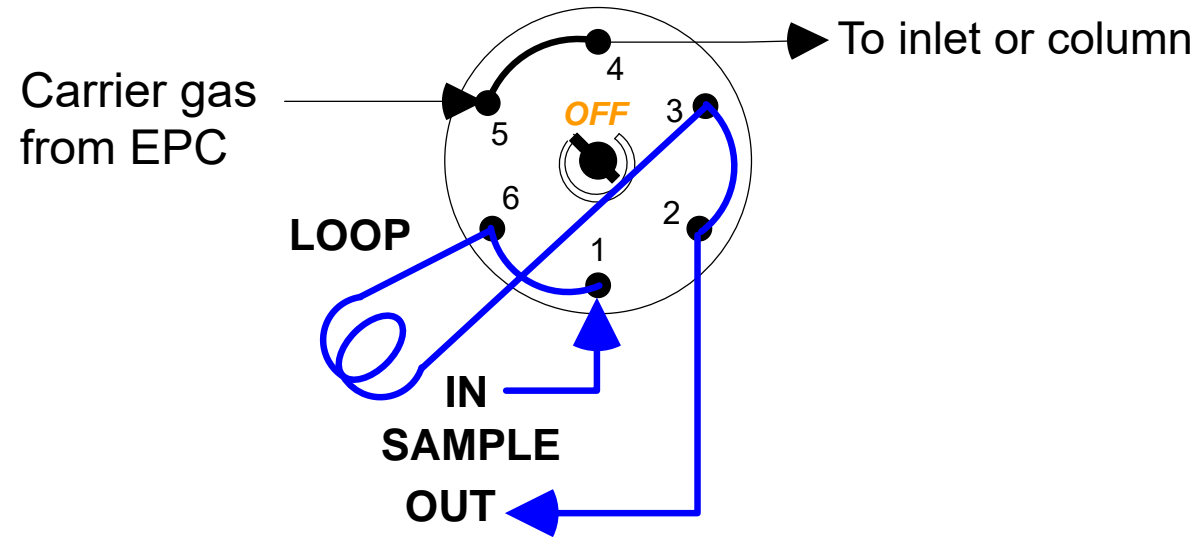

- With the valve *OFF*, sample flows freely through the sample loop and exits through the vent.
- Before injection, the sample flow is stopped.
- The sample loop vent is open to ambient pressure, allowing the loop to equilibrate to the same pressure before injection each time.

# 6-port Gas Sample Valve (GSV), G3540B, Opt 701

## Sample inject

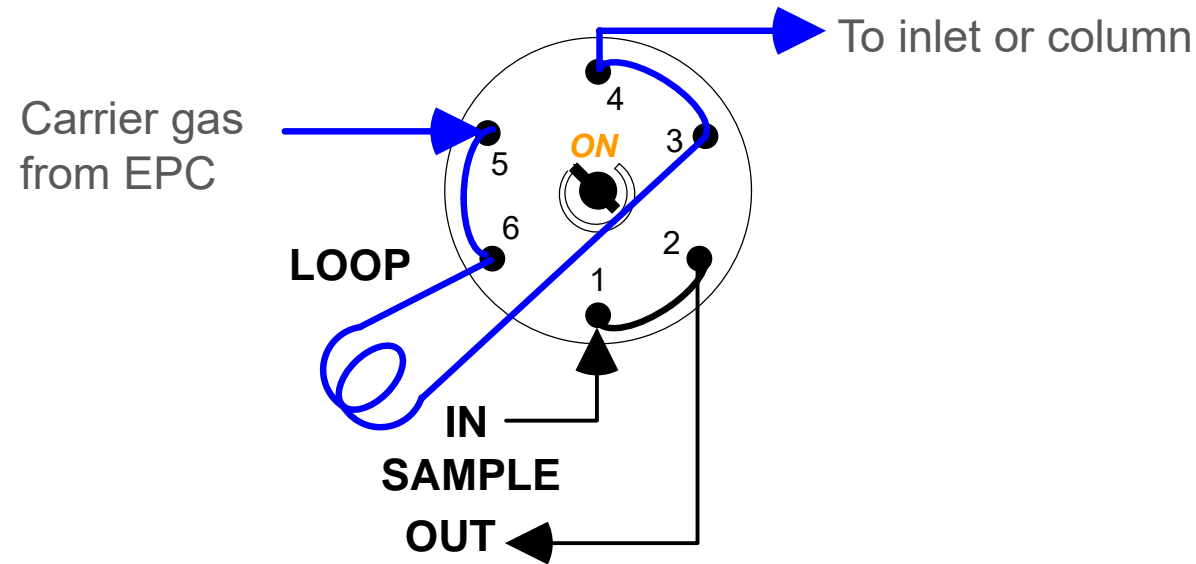

- On injection, the valve is turned *ON* and the sample is swept from the sample loop by carrier gas to the inlet or directly to the column.
- After the sample has flowed from the loop to the inlet/column, the valve is turned back to the *OFF* position during the GC analysis. This allows the sample loop to be prepared for the next analysis.

# 6-Port Column Isolation Valve

G3540B, opt 702

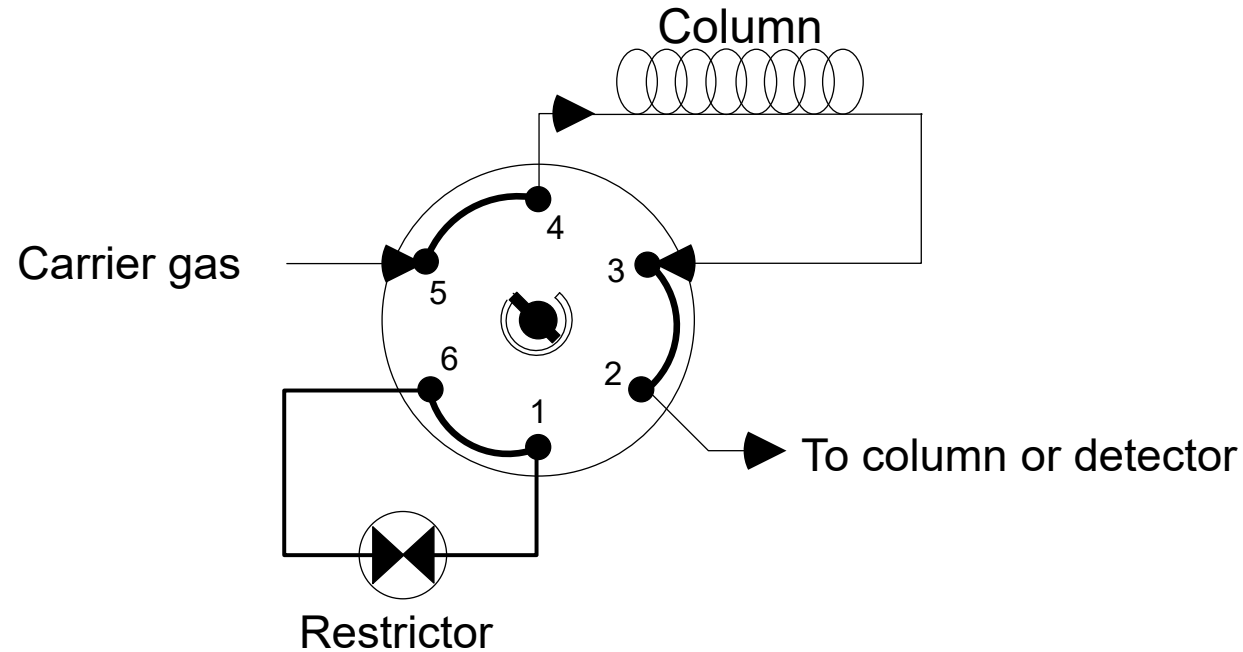

- Typically used when a column can irreversibly absorb components. This configuration is commonly used in permanent gas analysis to prevent heavy components from adsorbing onto a Molsieve column.
- The column can be isolated from the flow path and bypassed.
- The restrictor balances the flow across the valve and eliminates a drop in back pressure when the valve switches to the *ON* position.

# 6-Port Column Isolation Valve

G3540B, opt 702

## Column in series

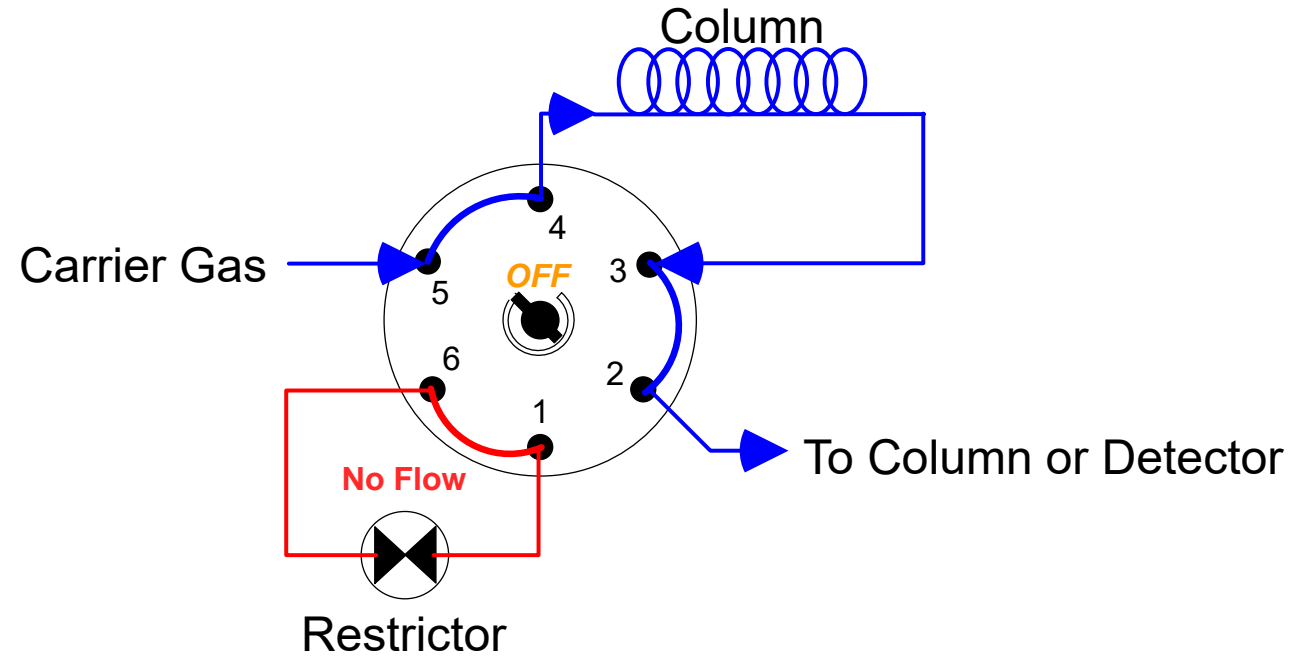

- In the *OFF* position, the carrier gas and components flow through the column and out to the detector.
- The restrictor is isolated and there is no flow across the restrictor.



# 6-Port Column Isolation Valve

G3540B, opt 702

## Restrictor in series

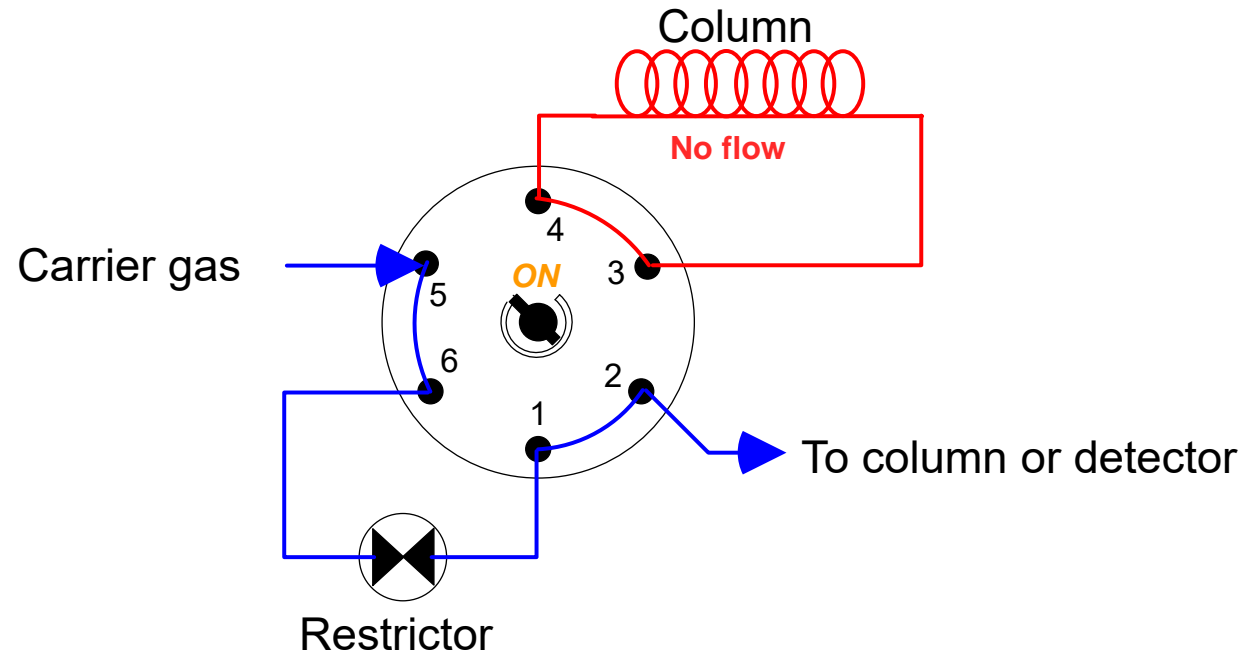

- In the *ON* position, the carrier gas and components are routed through the bypass restrictor.
- The column is isolated and the flow is diverted across the restrictor. This also isolates the molecules on column and allows components that would adsorb onto the column to bypass the column to the detector. Once heavy components have migrated past the column, the valve can be switched *OFF* and allow components retained on the column to elute.

# 6-Port Sequence Reversal w/Precolumn BF

G3540B, opt 708

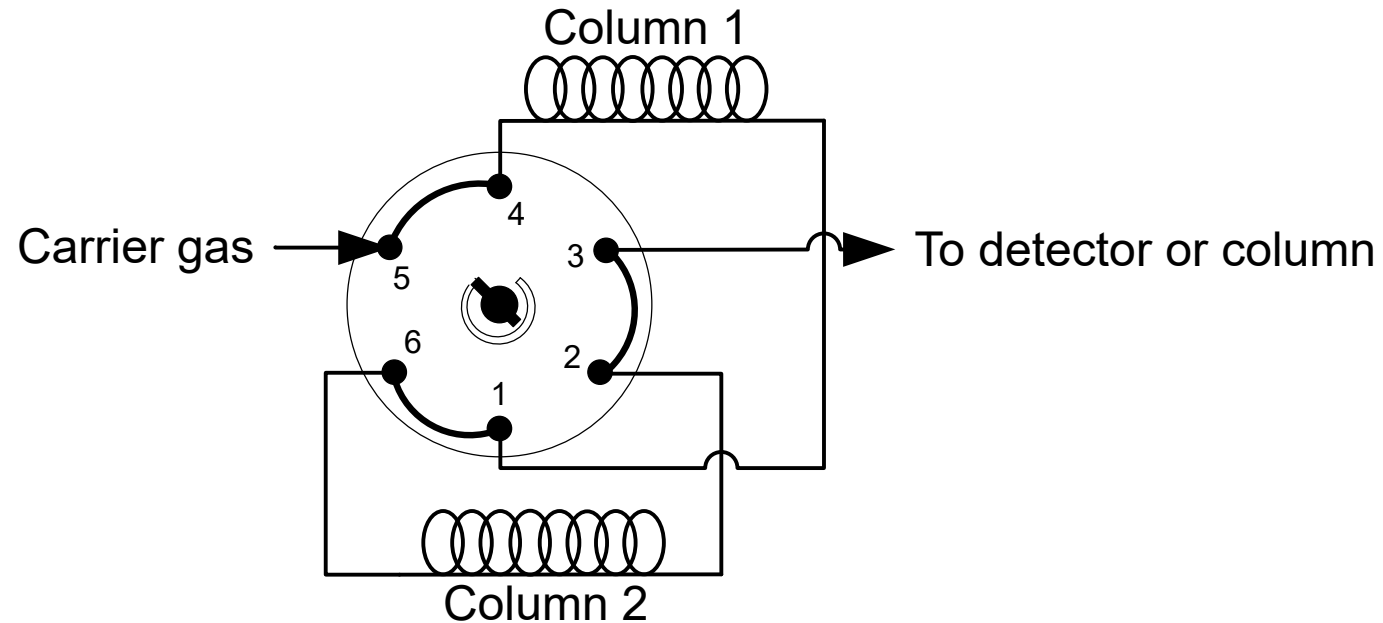

- Allows column 1 to switch positions with column 2 relative to each other like opt 707, but incorporates a backflush of column 1.
- The flow on column 1 is reversed when the valve switches, backflushing the components on the column out to the detector.
- Commonly used in refinery gas and natural gas applications where a C6+ or C8+ backflush is needed.

# 6-Port Sequence Reversal w/Precolumn BF

G3540B, opt 708

Inject mode

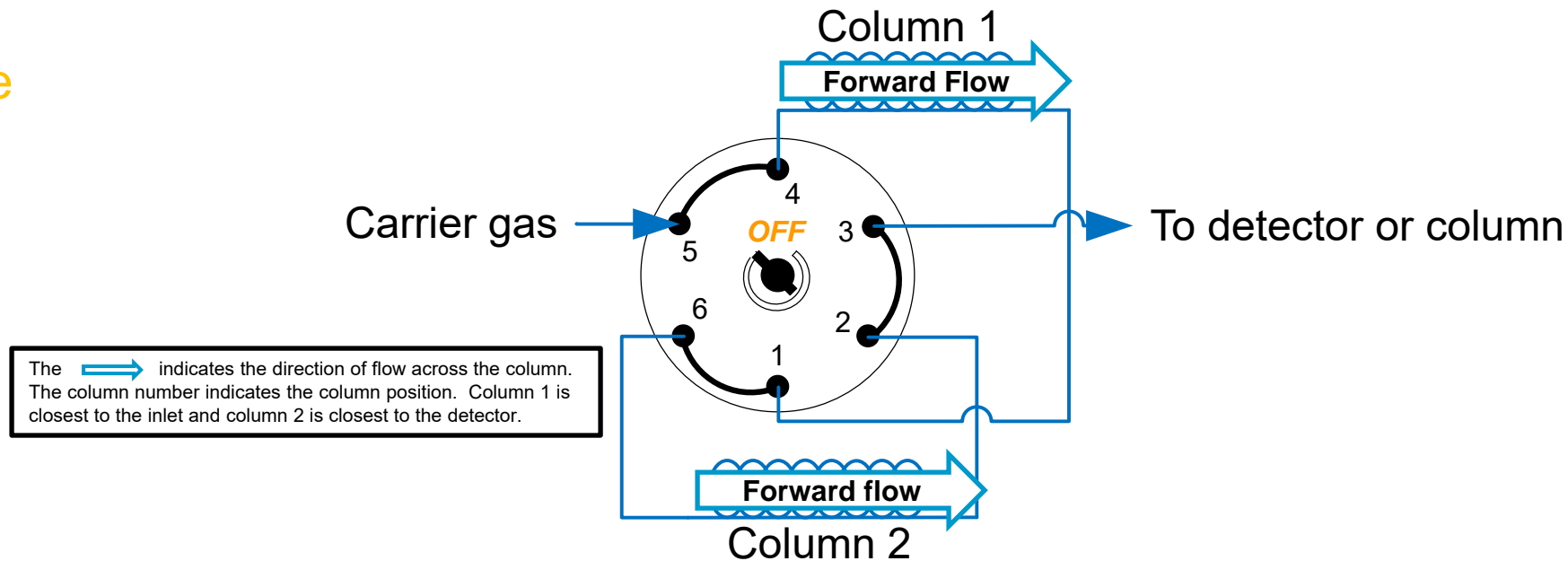

- On injection, the valve is in the *OFF* position. The components flow through column 1 to column 2. In this position, column 2 is downstream of column 1.
- Larger molecules are retained on column 1 and lighter molecules elute through to column 2.

# 6-Port Sequence Reversal w/Precolumn BF

G3540B, opt 708

## Backflush mode

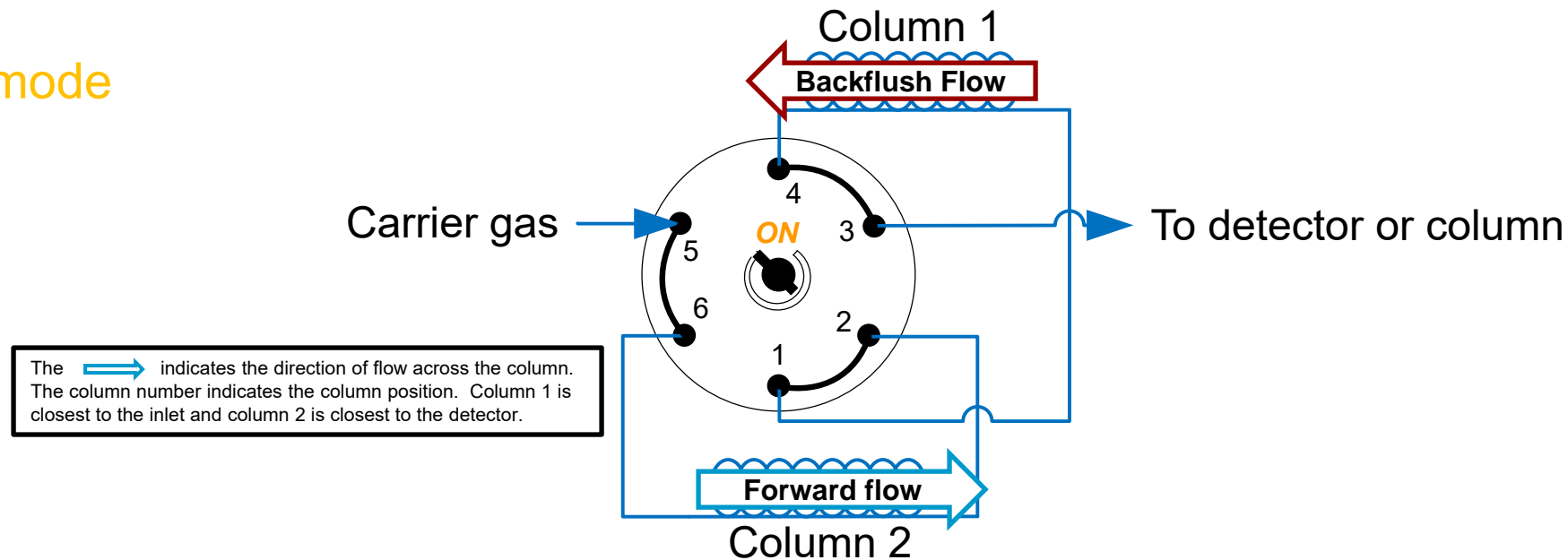

- After the components of interest have passed through the precolumn to the primary column, the valve is switched *ON*.
- Now column 1 flow has been reversed and it is downstream of column 2.
- The analytes on column 1 are backflushed to the detector as a lump sum peak. The flow for column 2 continues in the forward direction.

# How Are 10-port Valves Used in Gas Chromatography

In this section we will discuss the most common 10-port valve configurations and how they are used in chromatography.

There are a multitude of ways to configure a valve so we will start simple and work up in complexity, explaining the most common configurations of the 10-port valve and how they are used in chromatography.

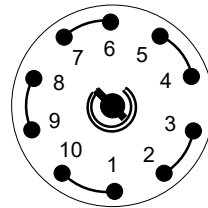

10-port rotary valve

# Common 10-port Valve Configurations

Including option numbers used to order preconfigured on a G3440B 8890B GC

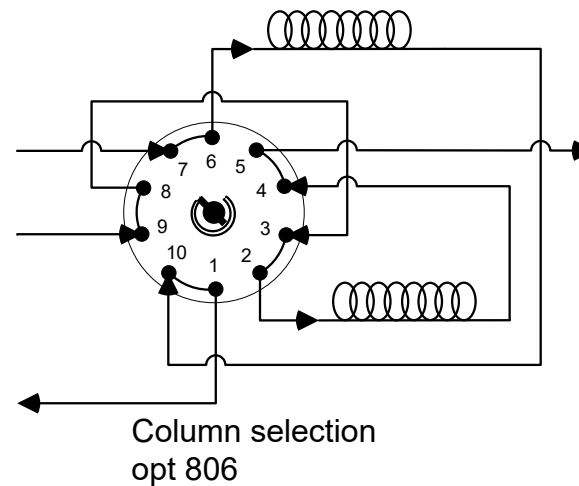
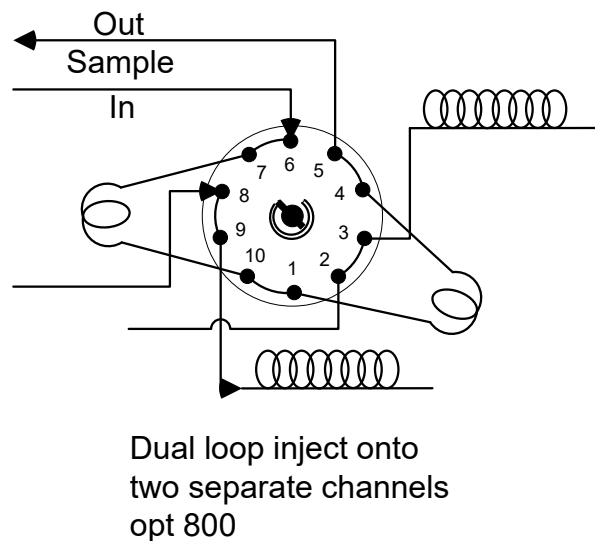
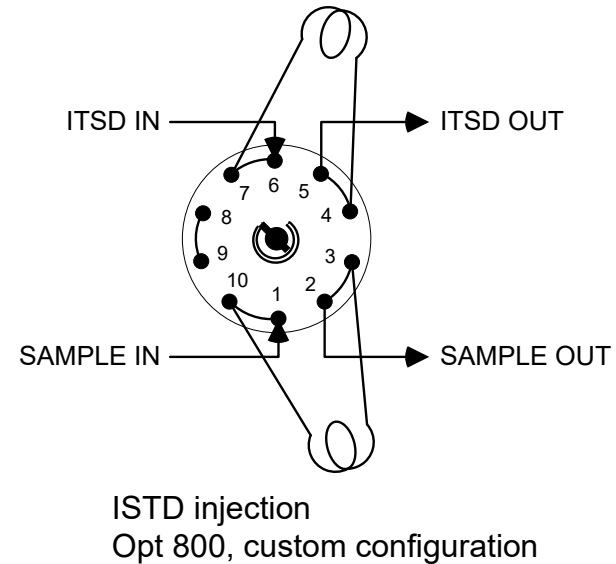
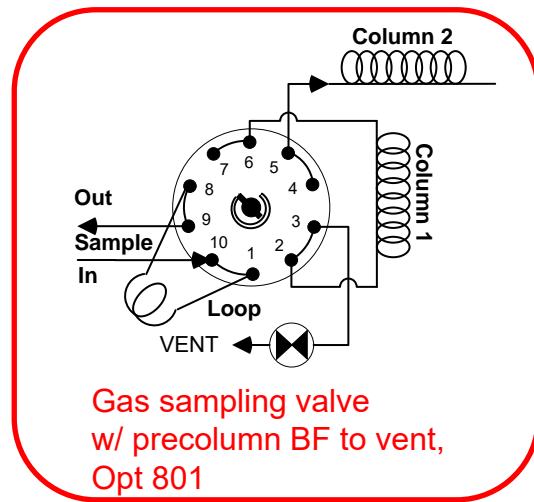

# 10-Port GSV w/Precolumn Backflush to Vent

G3540B, opt 801

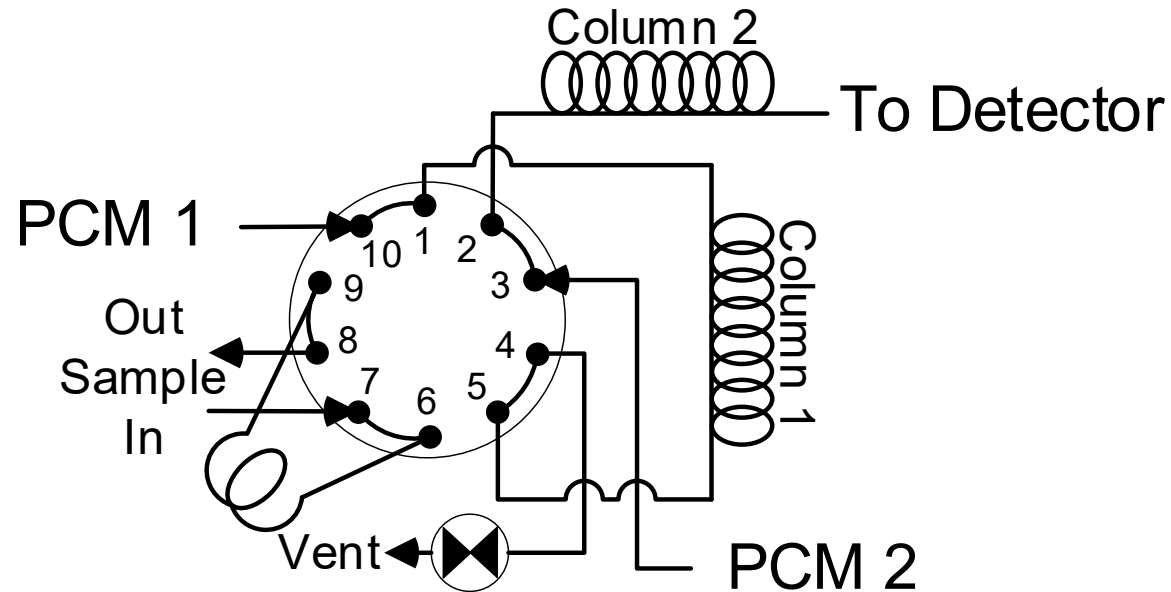

- Provides a method of injecting a fixed volume of gas into a GC inlet or directly onto a column.
- May be used to shorten analysis time when late-eluting compounds need not be measured.

# 10-Port GSV w/Precolumn Backflush to Vent

G3540B, Opt 801

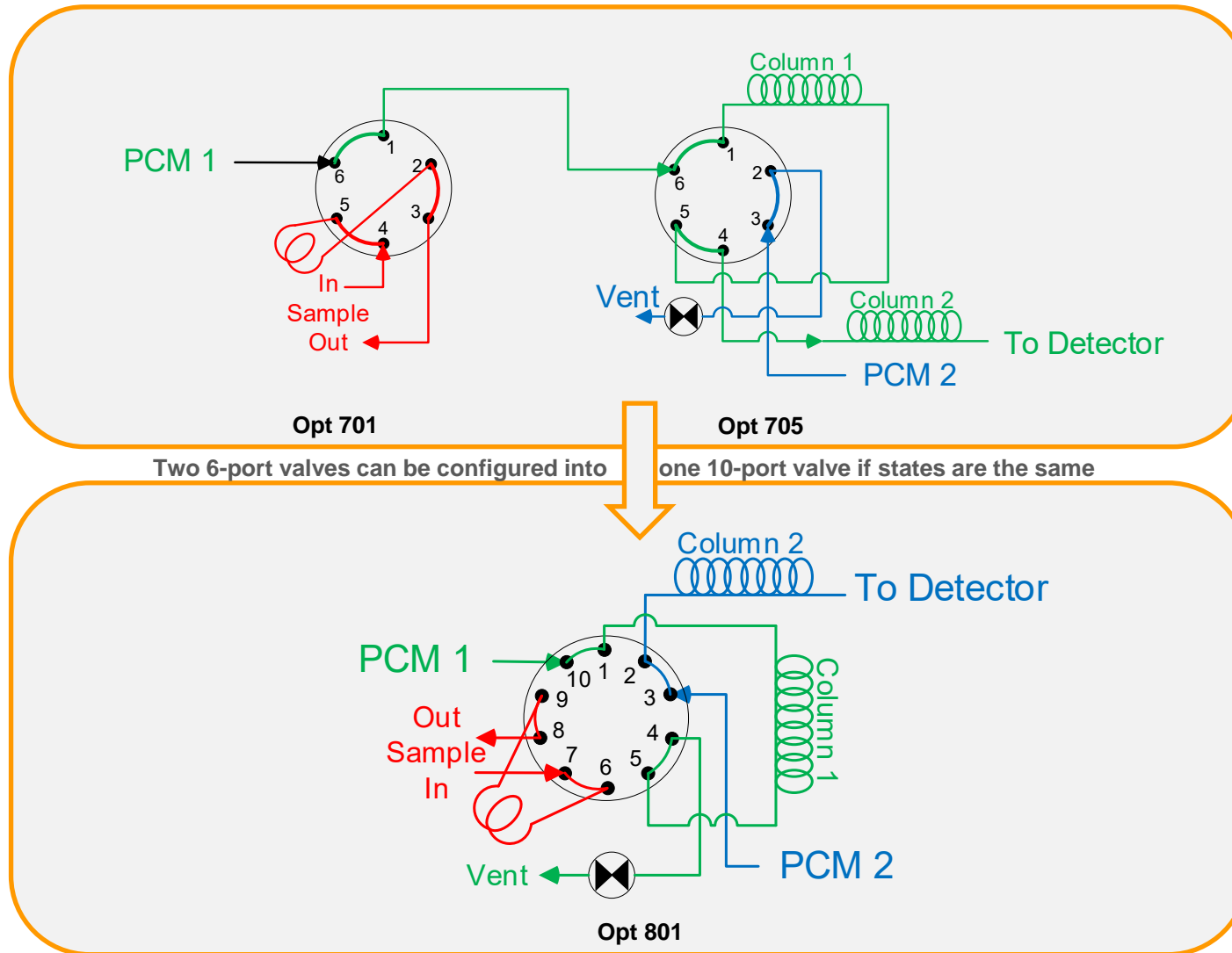



# 10-Port GSV w/Precolumn Backflush to Vent

## G3540B, opt 801

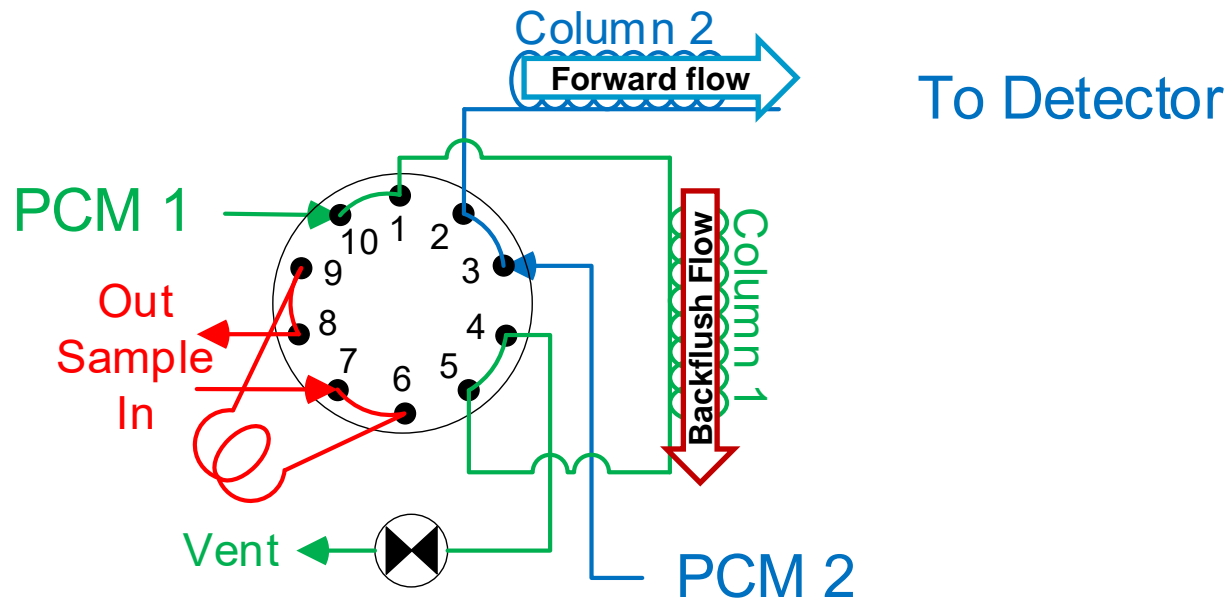

- When the valve is in the OFF position, the sample is loaded in the sample loop.
- Column 1 is backflushed to vent and column 2 flows towards the detector.
- Analytes that are on column 1 will be backflushed to vent. Analytes on column 2 will continue to elute to the detector.

# 10-Port GSV w/Precolumn Backflush to Vent

## G3540B, opt 801

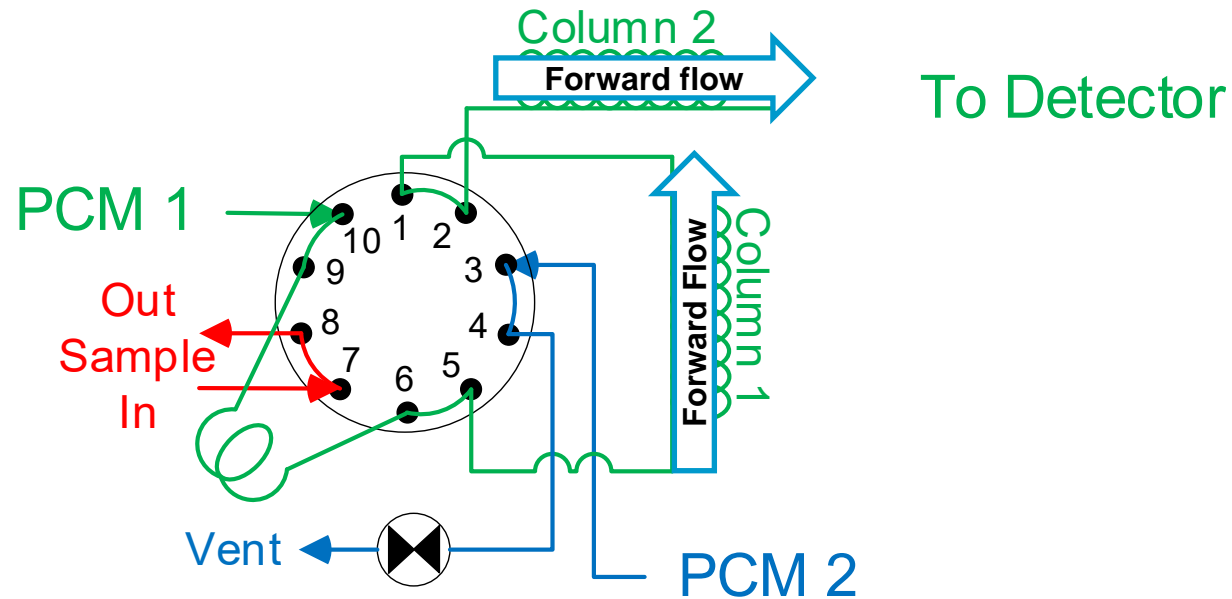

- When the valve is in the ON position the sample that is contained in the loop is injected onto column 1 and flows to column 2.
- Components that are more retentive for column 1 are retained on column 1 and less retentive analytes are allowed to flow through to column 2. Once the analytes of interest have flowed through to column 2 the valve can be switched back to the *OFF* position to backflush column 1.

# Using Multiple Valves to Build a Complex Solution: Fast Refinery Gas Analysis

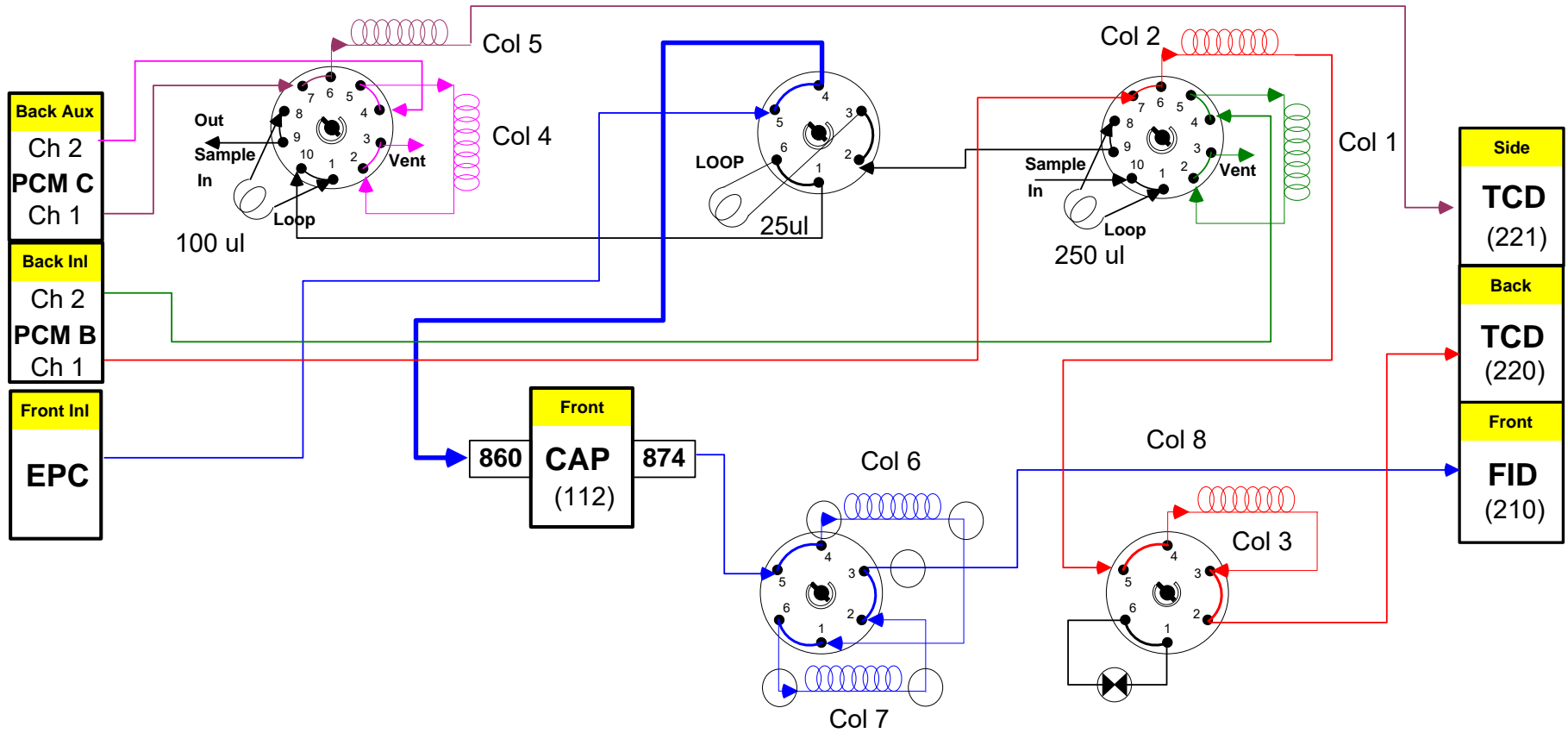

# Agilent SVO Fast Refinery Gas Analyzer

## Utilizes four types of rotary valves

Valves are always depicted in the OFF position unless otherwise noted

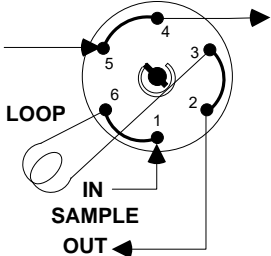

6-port GSV (opt 701)

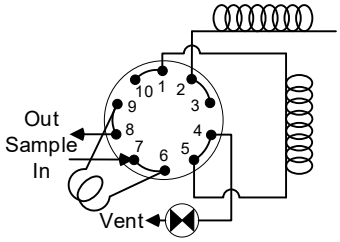

10-port GSV with precolumn backflush to vent (opt 801)

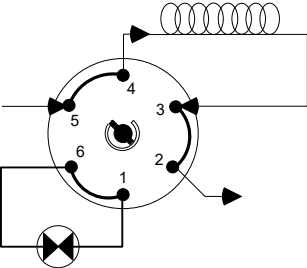

6-port column isolation valve (opt 702)

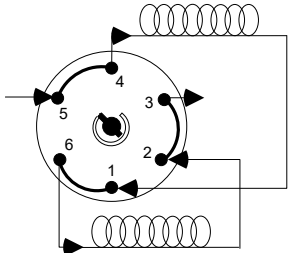

6-port sequence reversal with precolumn backflush to detector (opt 708)

# Agilent 8890-0322 Fast Refinery Gas System

Three channel system for analysis of hydrogen, permanent gases and hydrocarbon analysis

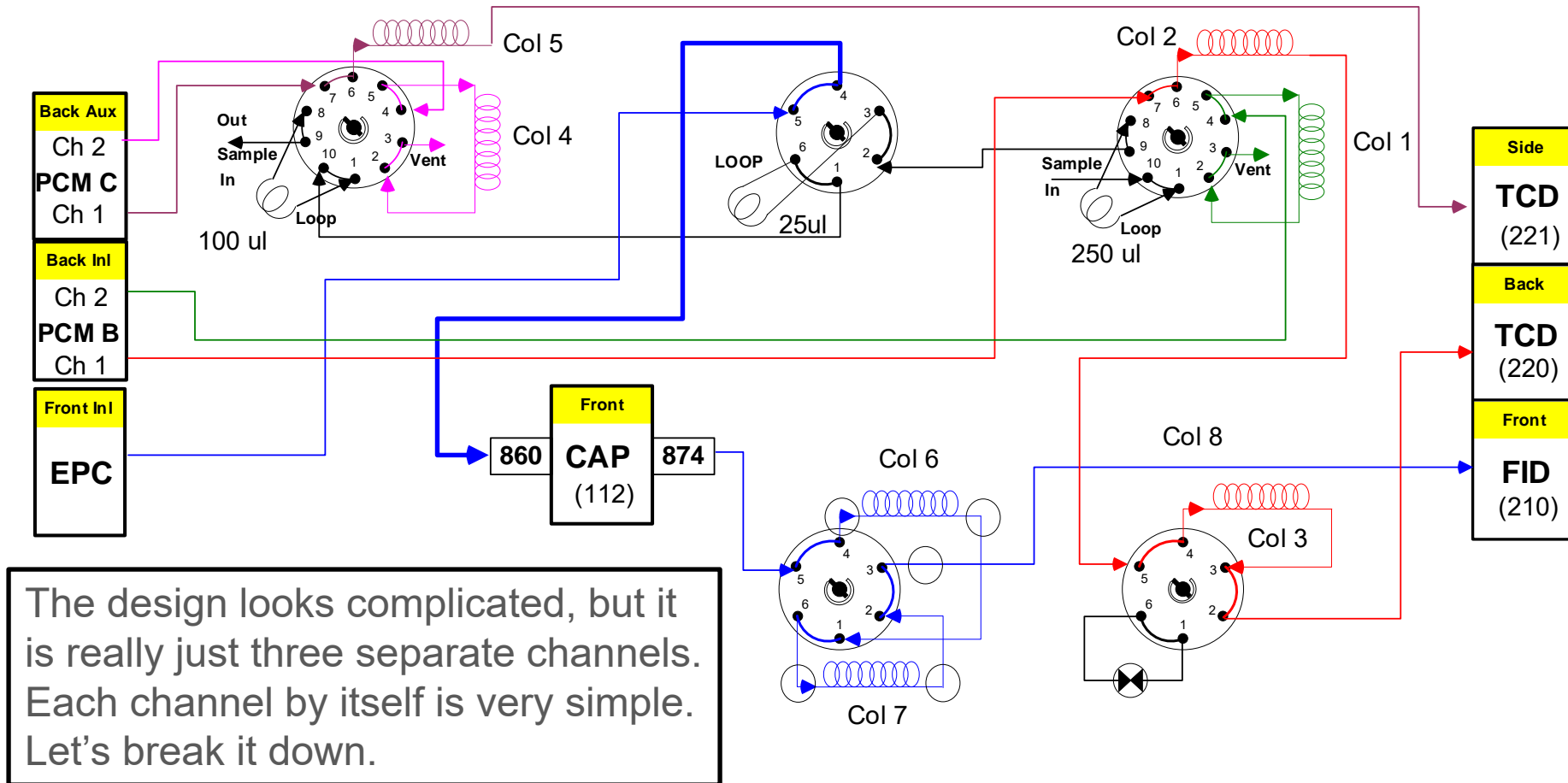

# Agilent 8890-0322 Fast Refinery Gas System

Three gas sample valves, one for each channel

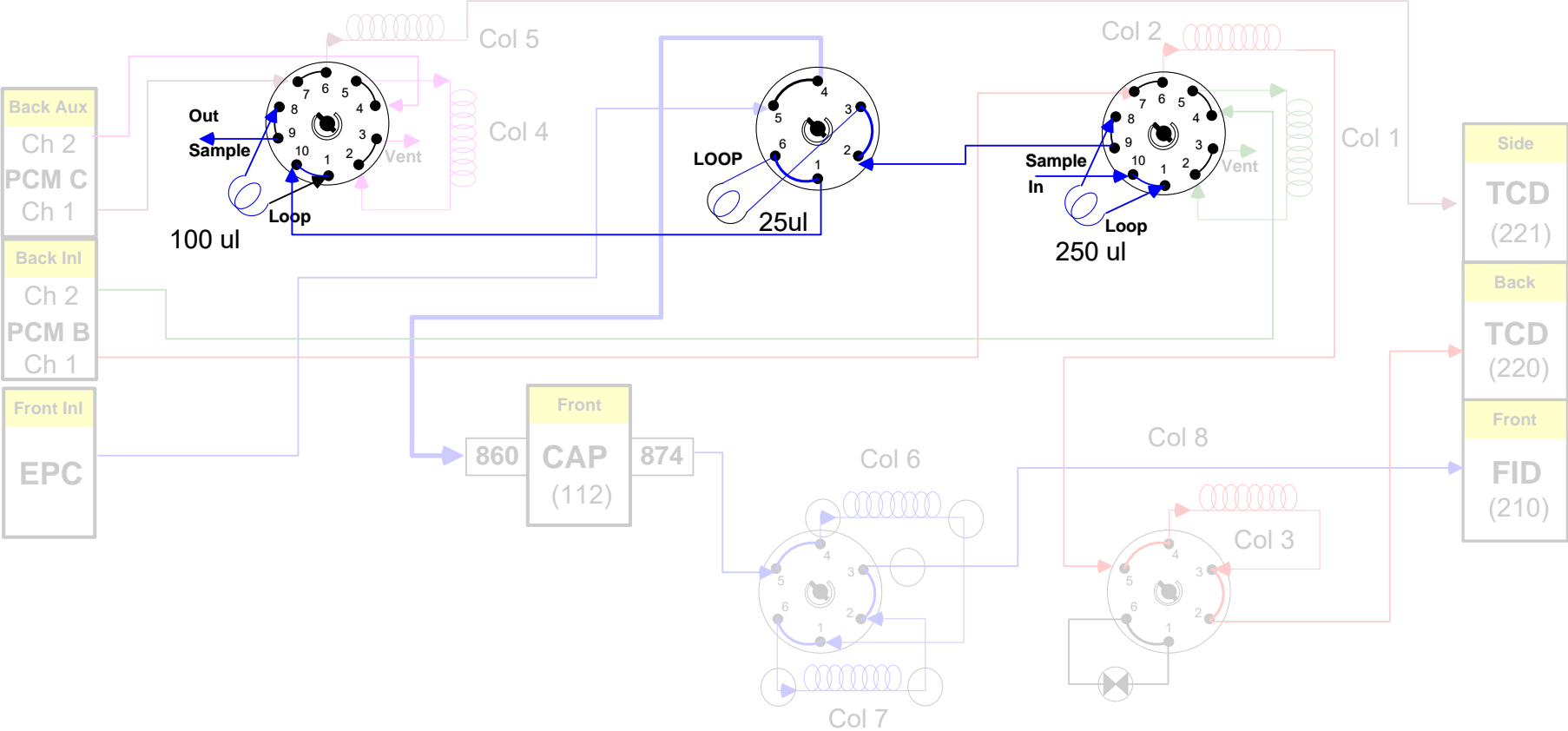

# Agilent 8890-0322 Fast Refinery Gas System

## Channel one: hydrogen analysis

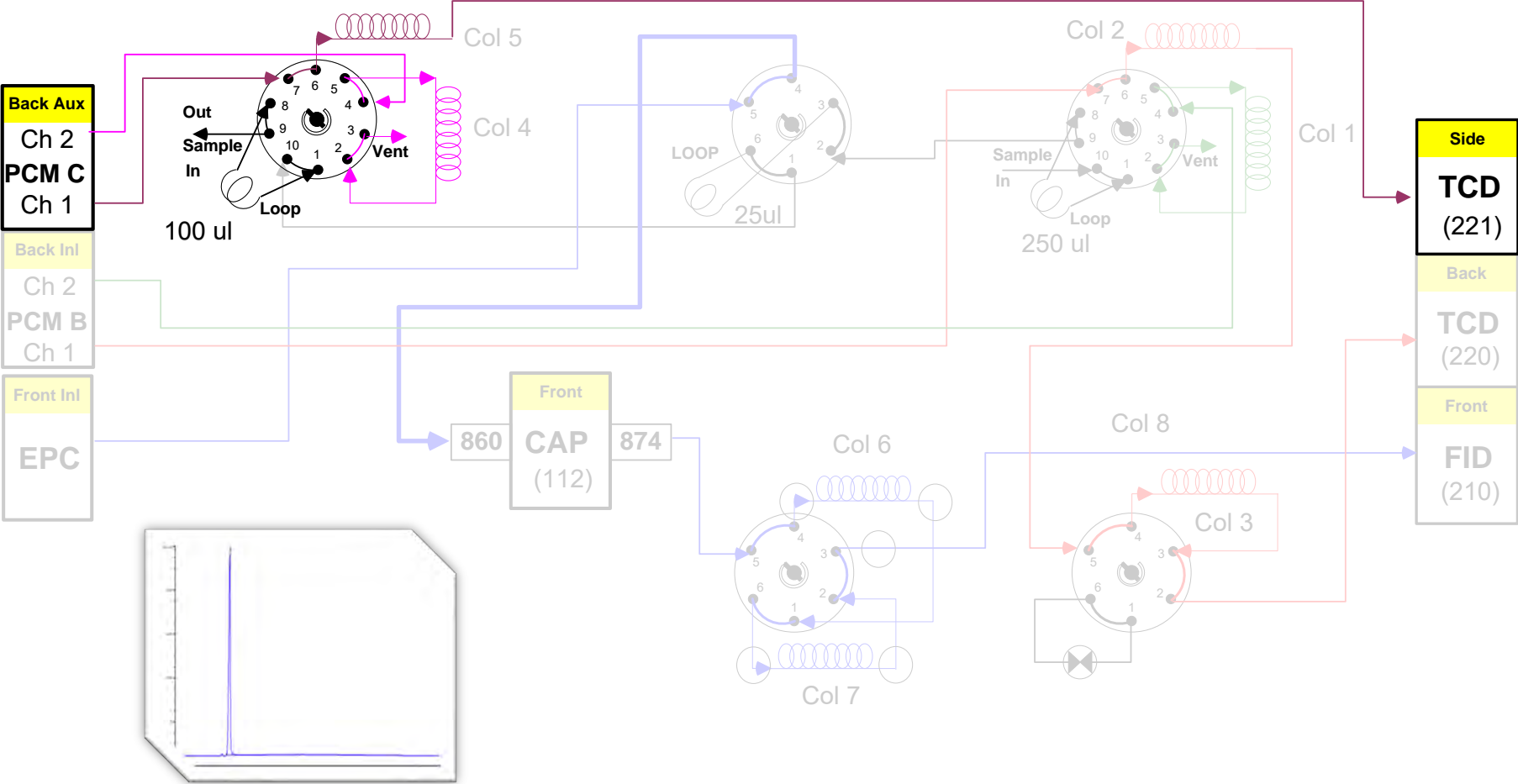

# Hydrogen Analysis

## Flow direction review

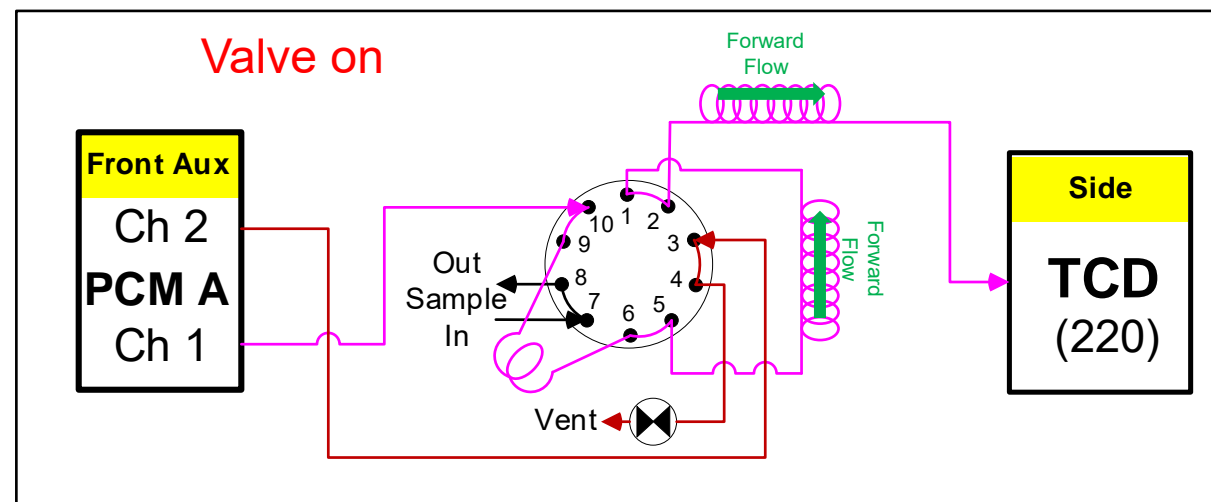
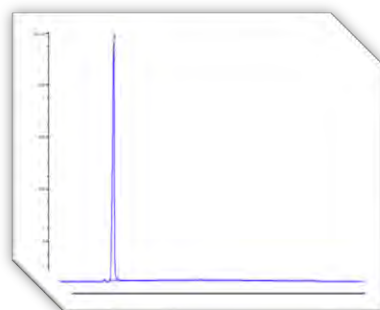
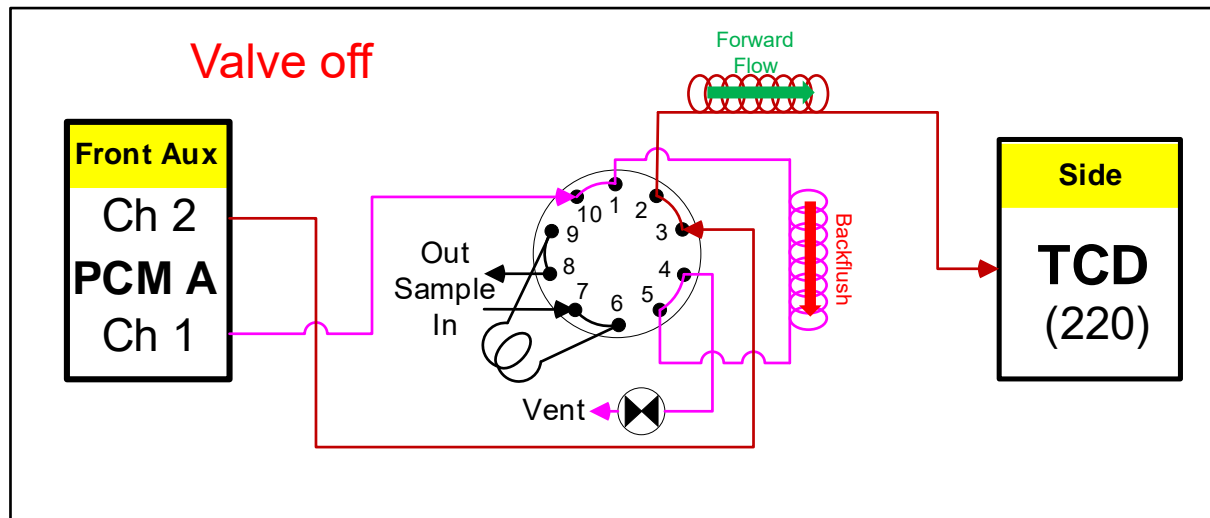



# Hydrogen Analysis

Sample load

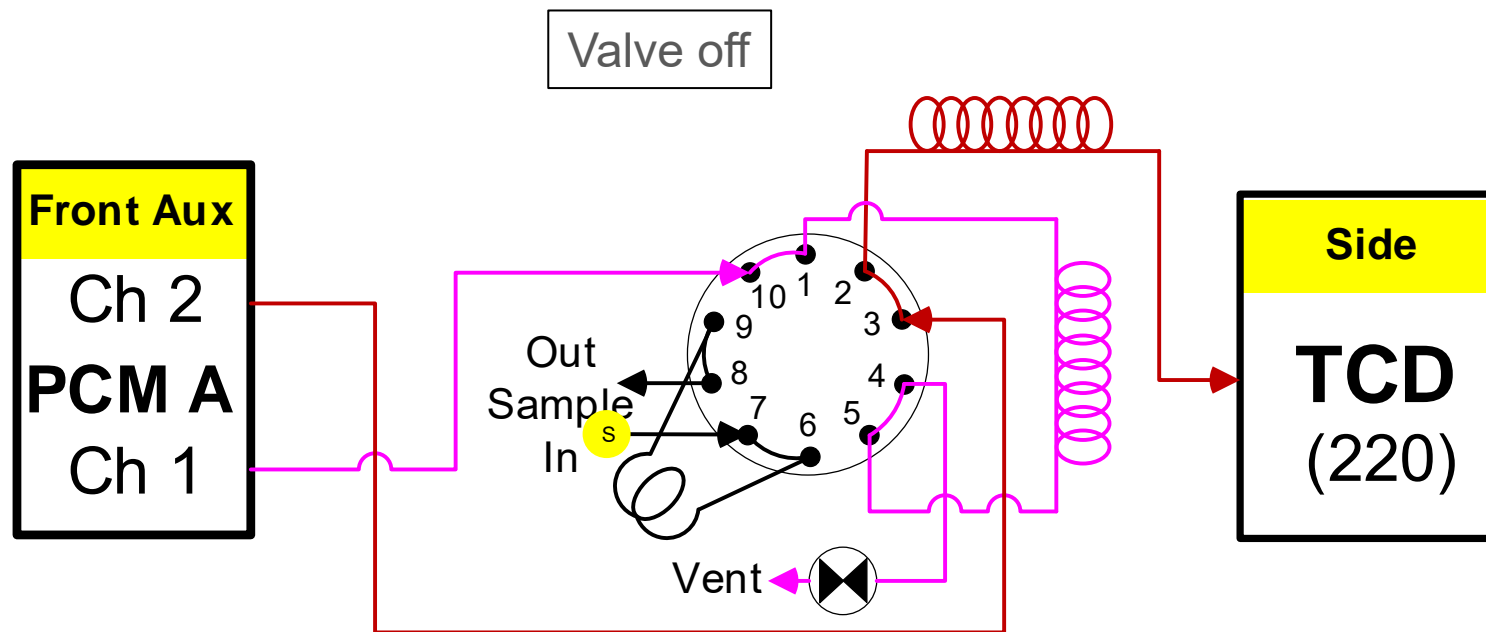

# Hydrogen Analysis

## Sample inject

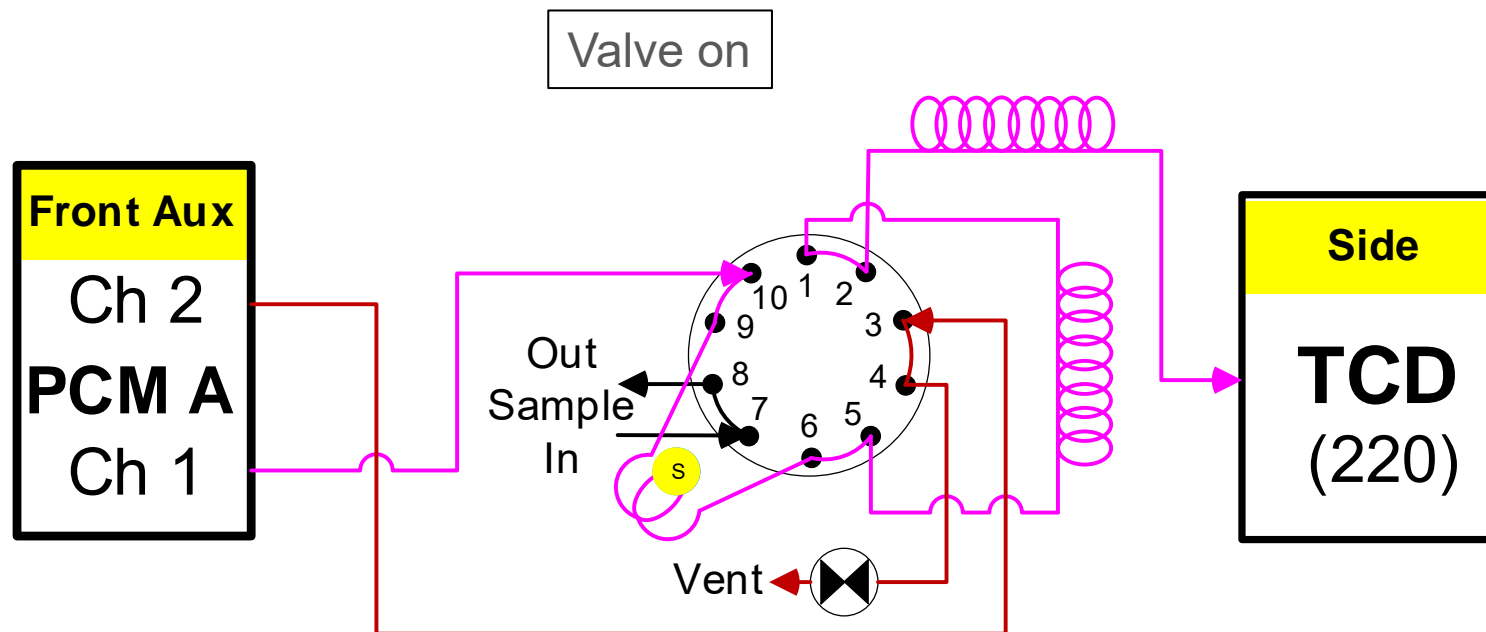

# Hydrogen Analysis

## CO<sub>2</sub> plus initial separation

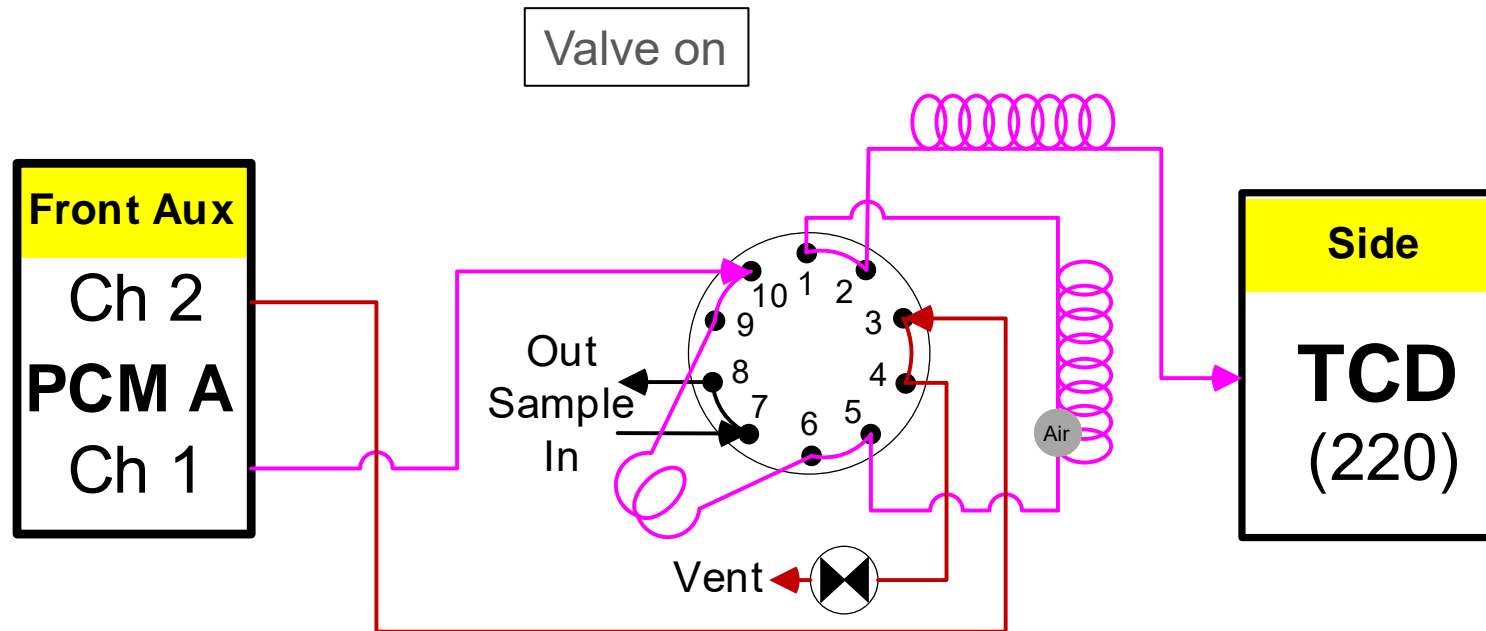

# Hydrogen Analysis

Final H<sub>2</sub> separation and CO<sub>2</sub> plus backflush

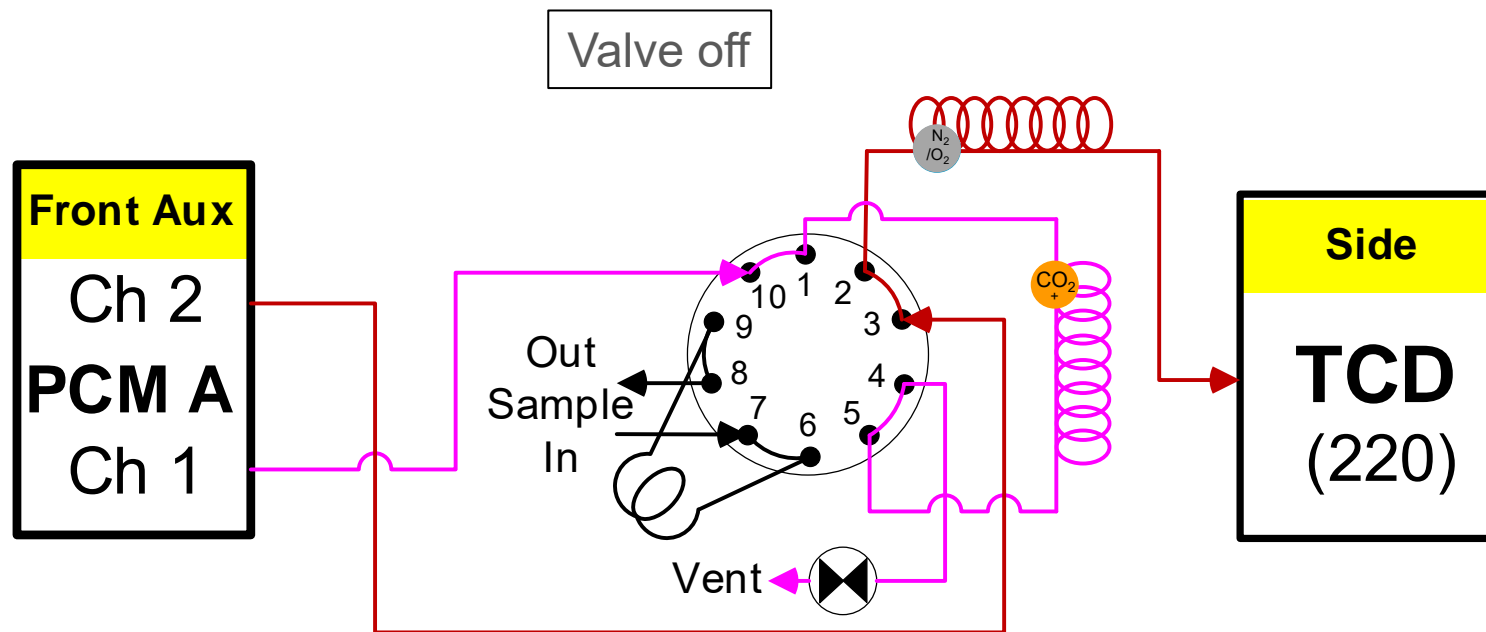

# Hydrogen Analysis

## Example chromatogram

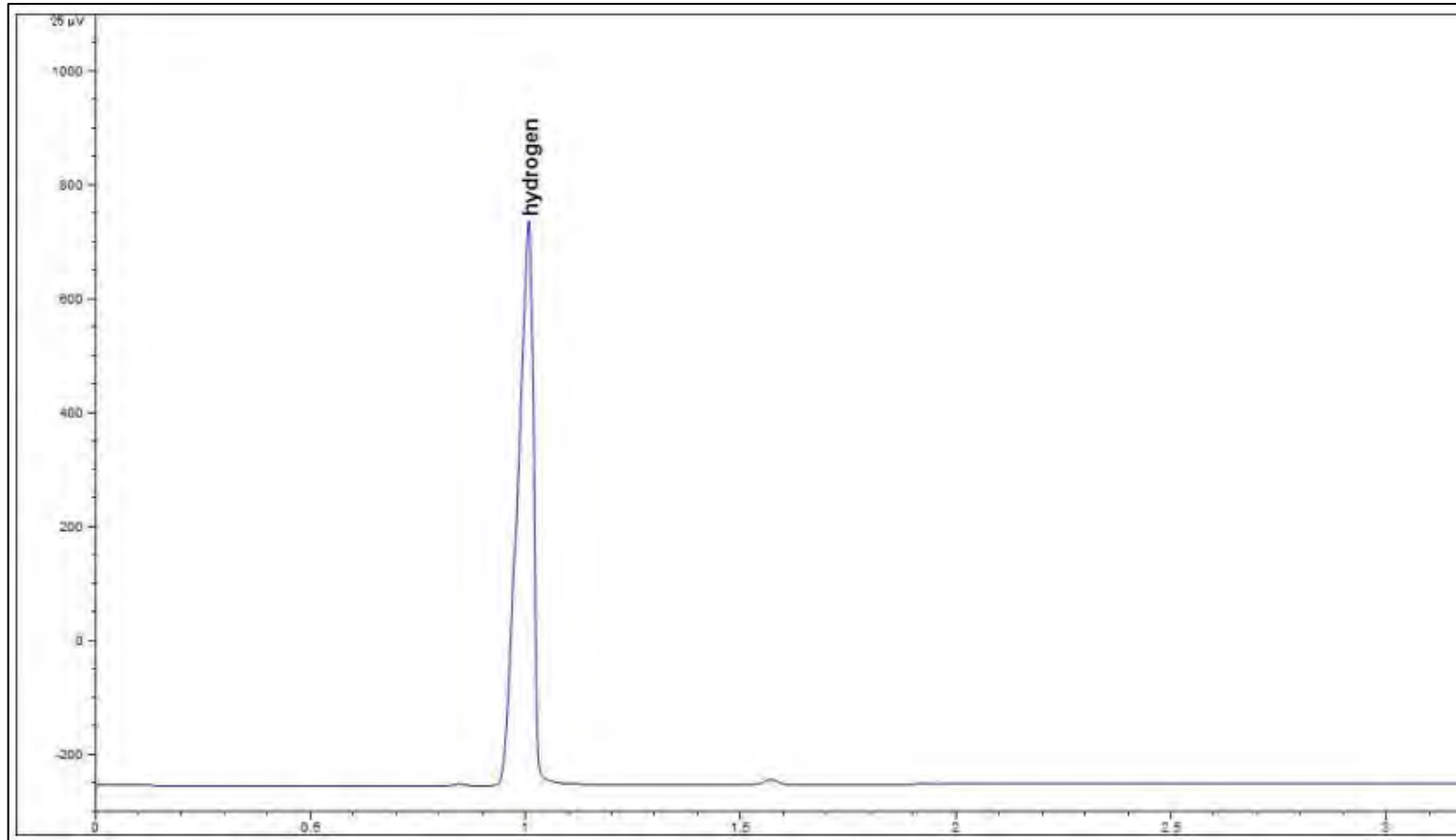

# Agilent 8890-0322 Fast Refinery Gas System

## Channel two: permanent gas analysis

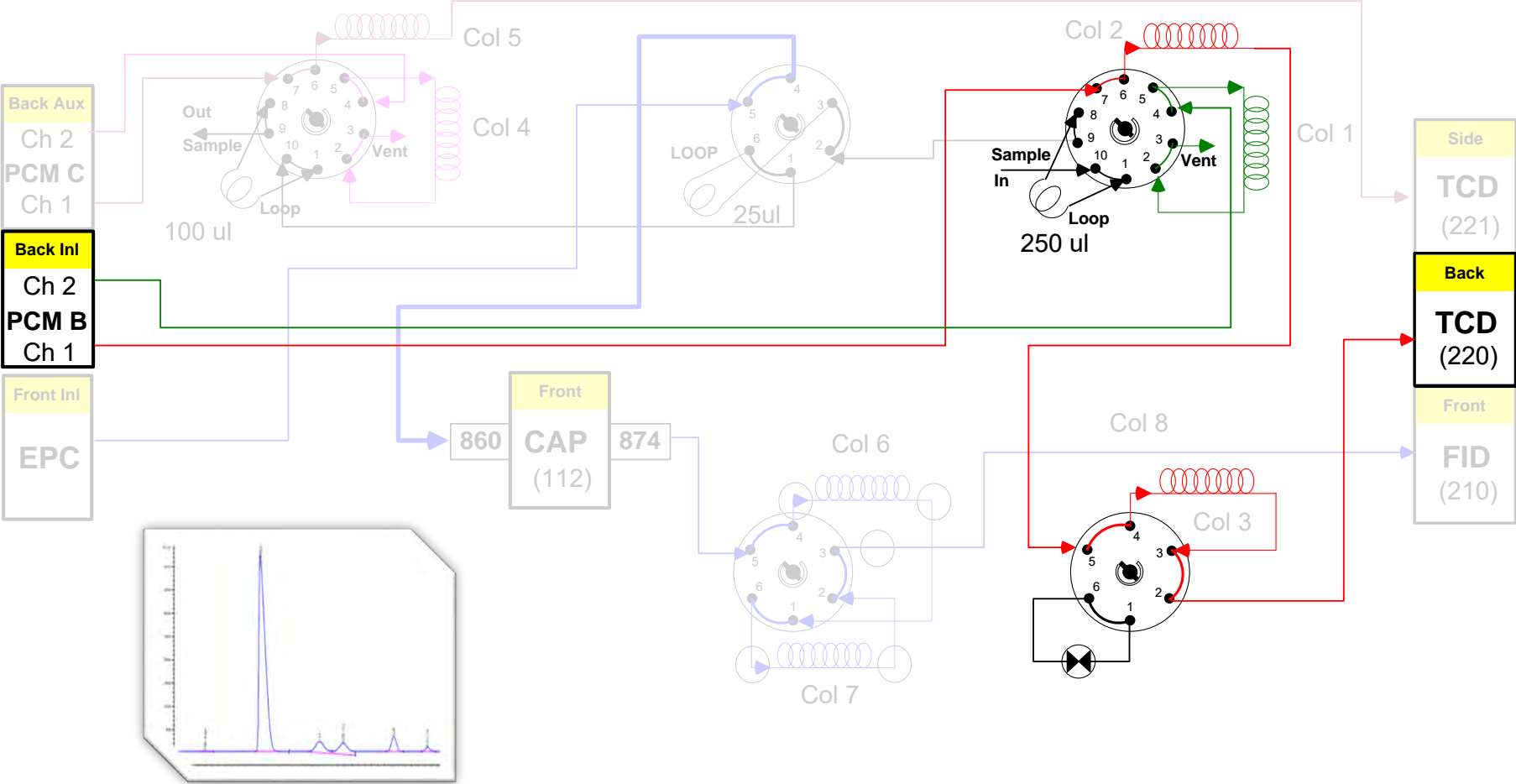

# Permanent Gas Analysis

## Flow direction review

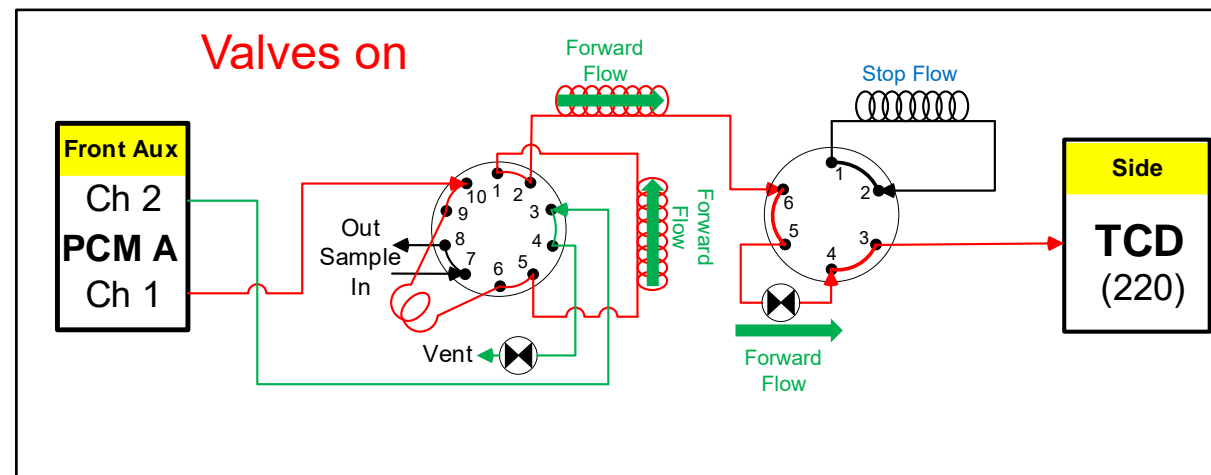
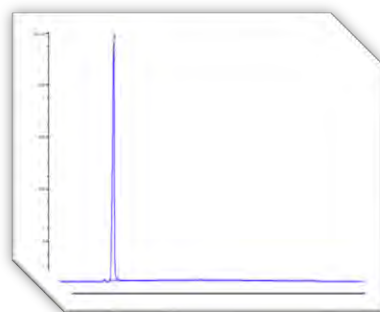
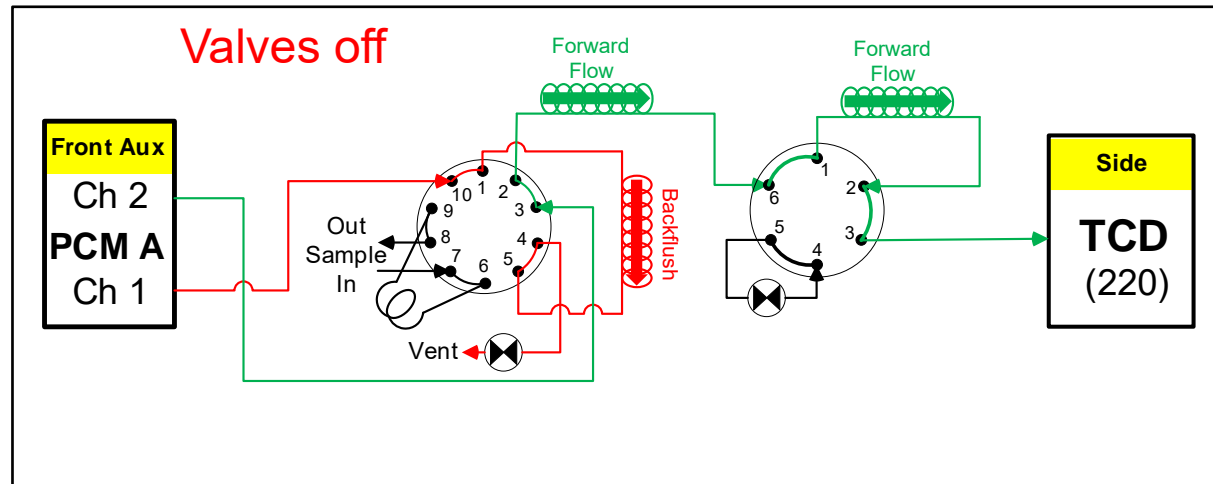

# Permanent Gas Analysis

## Sample load

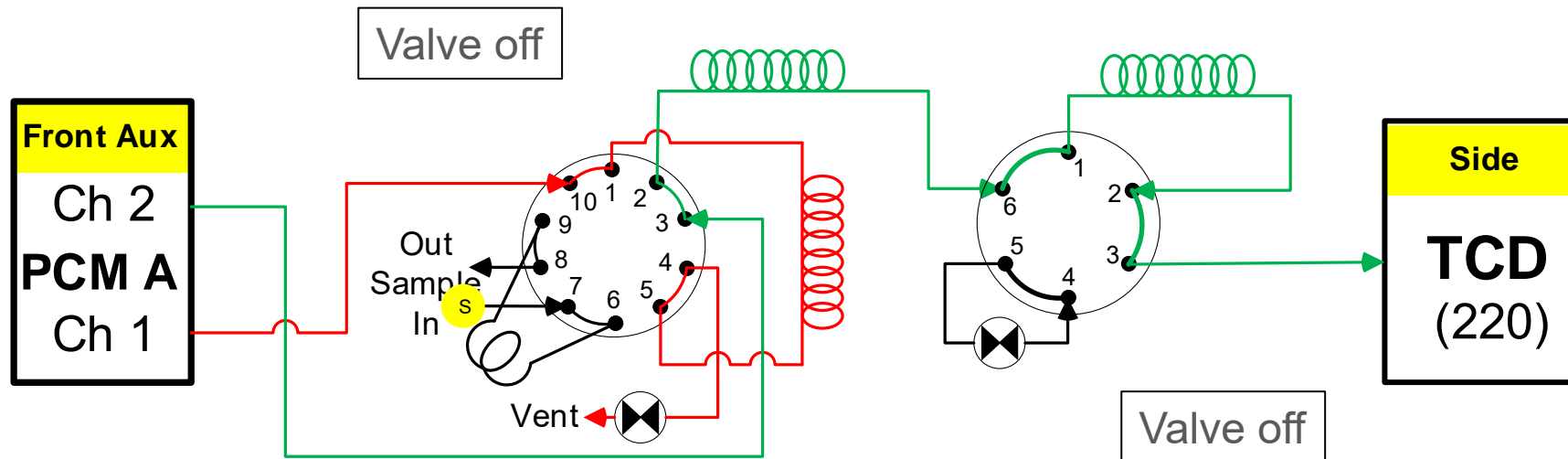



# Permanent Gas Analysis

## Sample inject

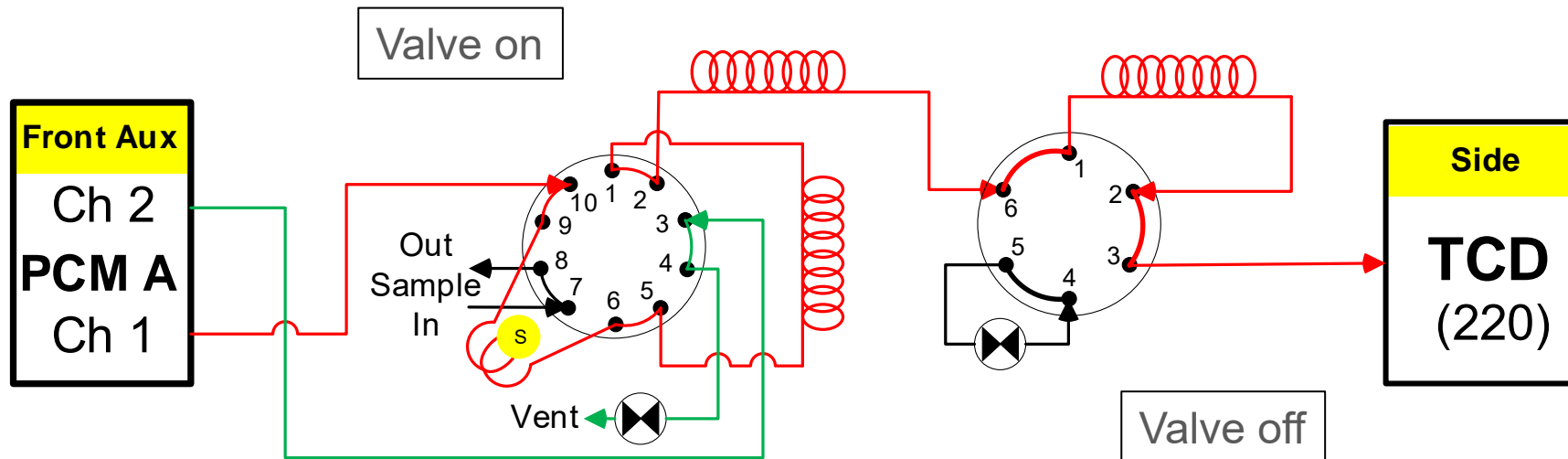

# Permanent Gas Analysis

## Propane plus initial separation

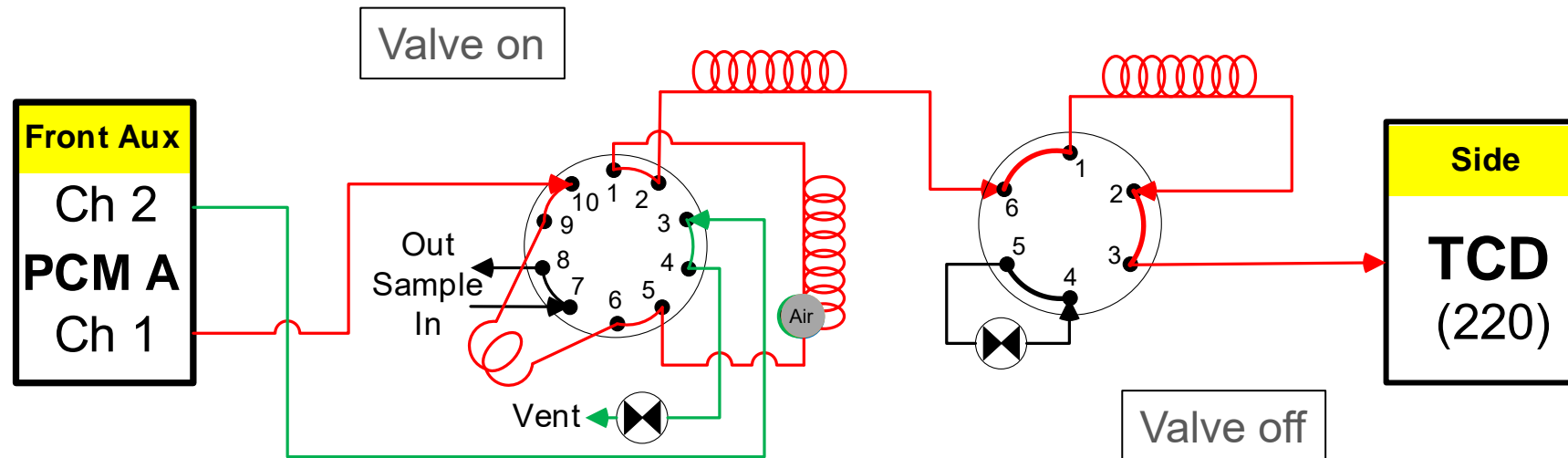

# Permanent Gas Analysis

Propane plus backflush and Molsieve bypass

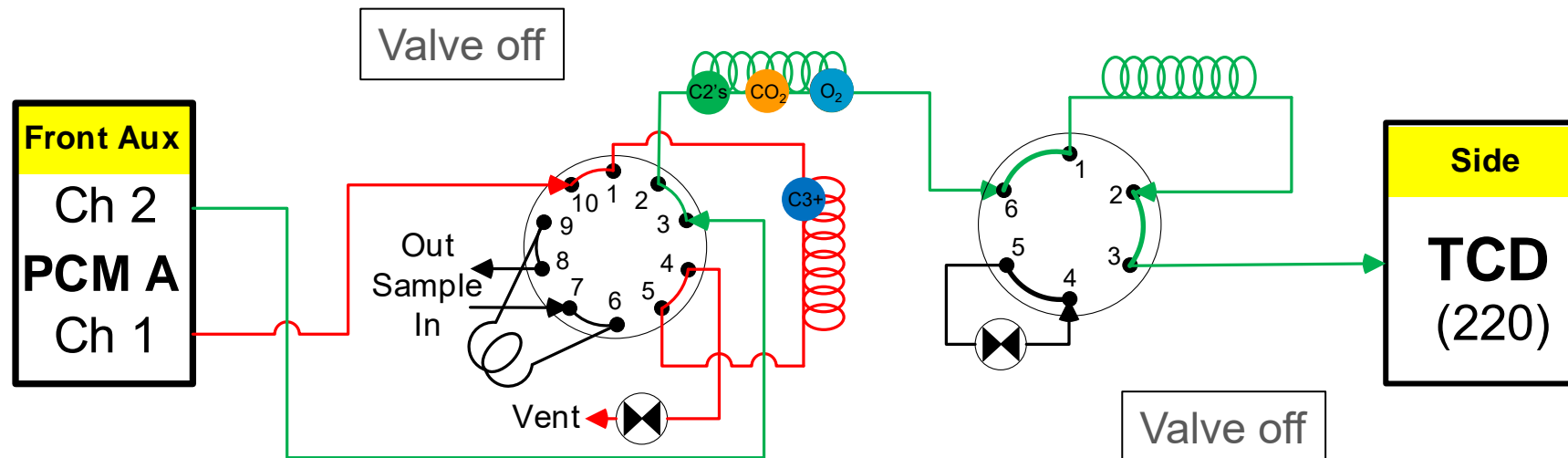

# Permanent Gas Analysis

Propane plus backflush and CO<sub>2</sub> and C2's elution

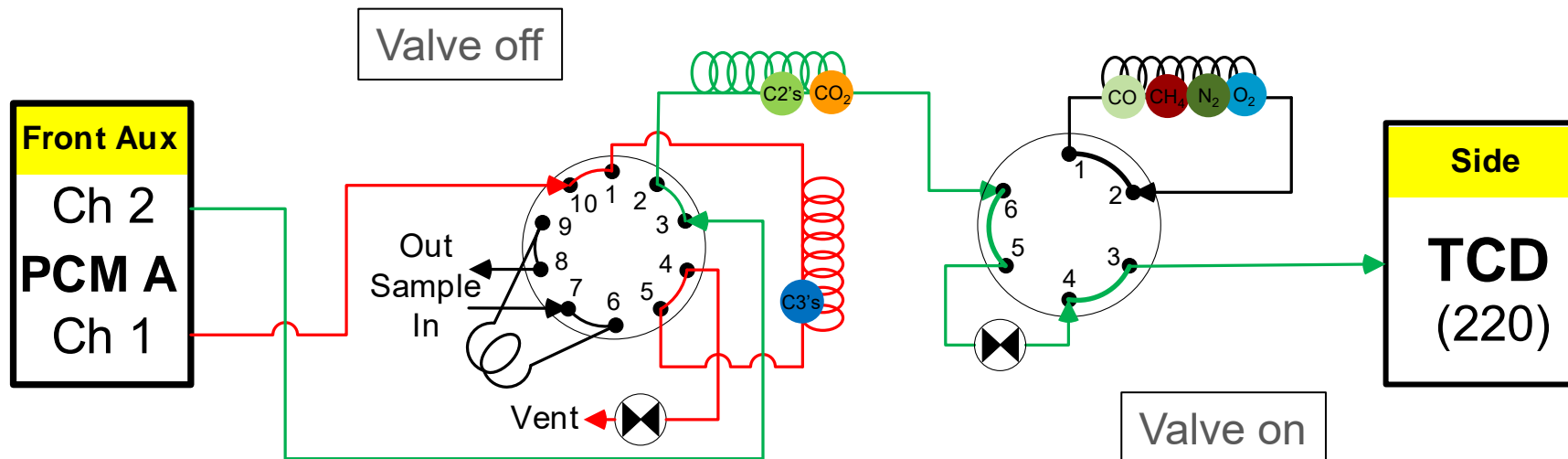

# Permanent Gas Analysis

## Elution of Molsieve

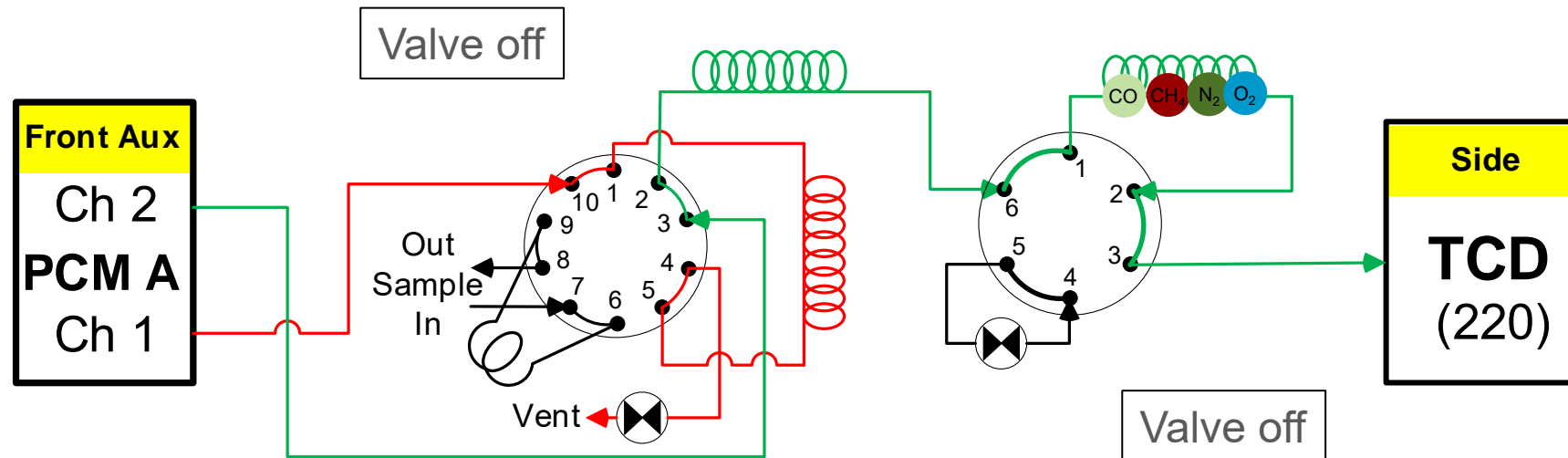

# Permanent Gas Analysis

## Example chromatogram

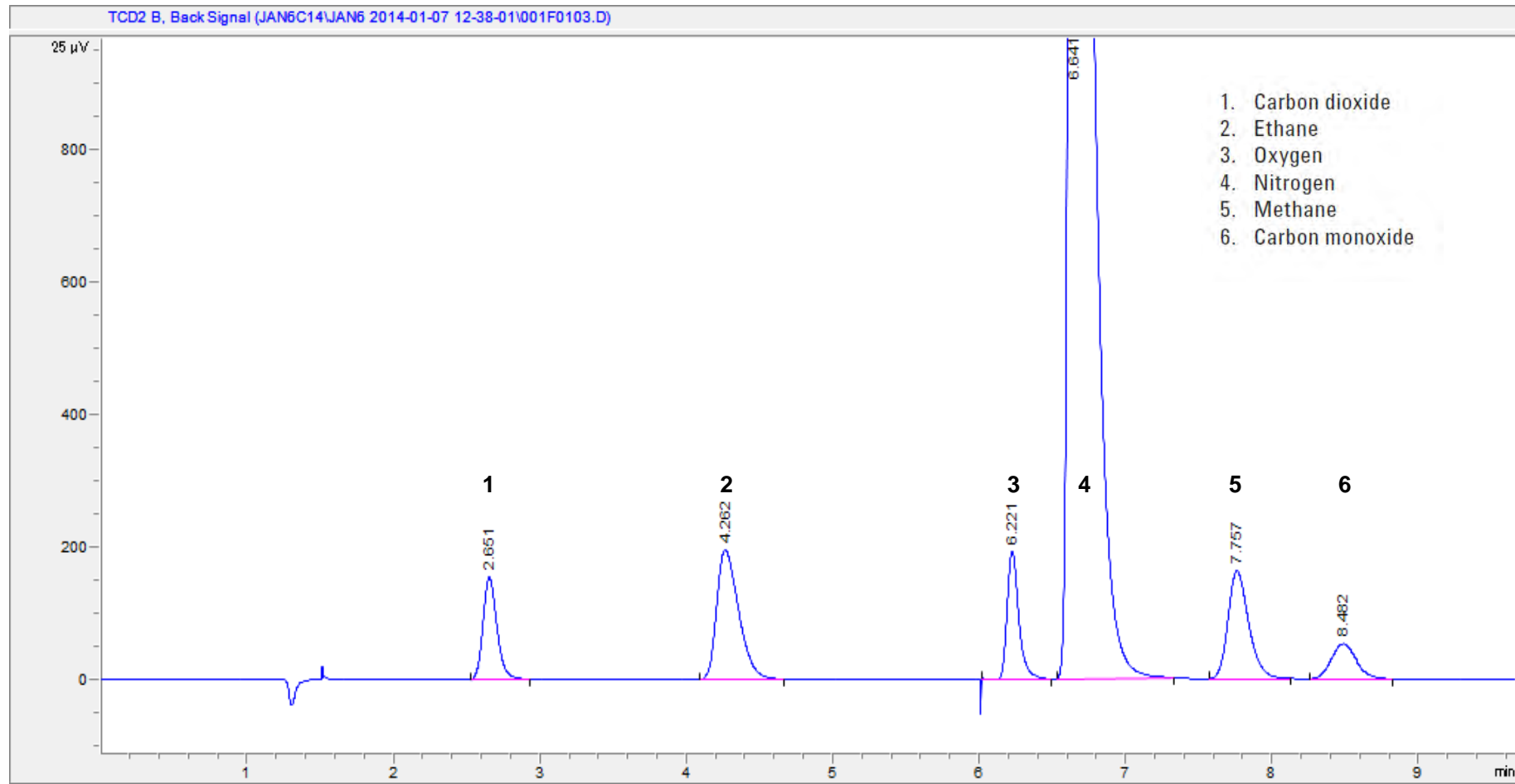

# Agilent 8890-0322 Fast Refinery Gas System

## Channel three: hydrocarbon analysis

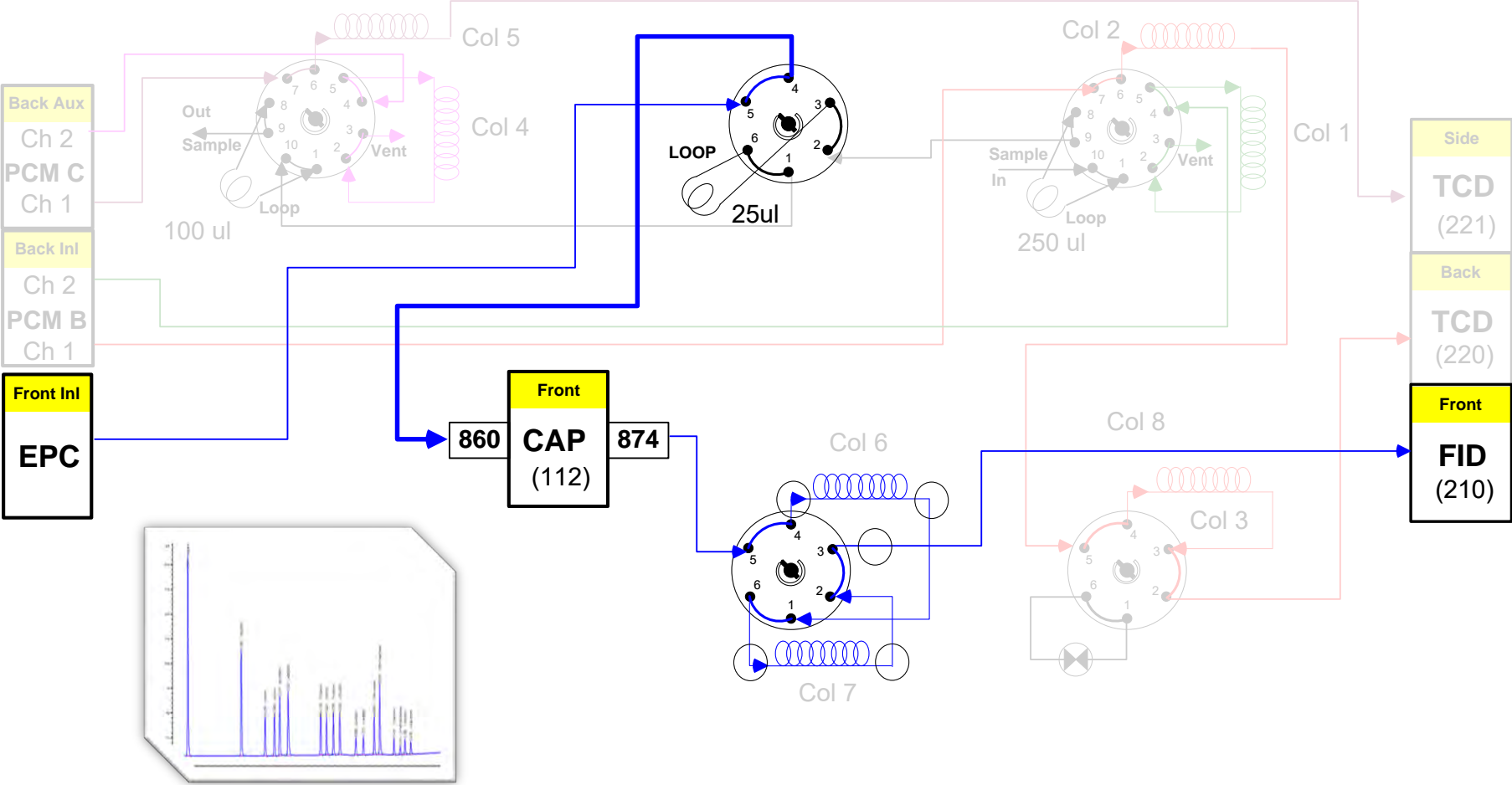

# Hydrocarbon Analysis

## Flow direction review

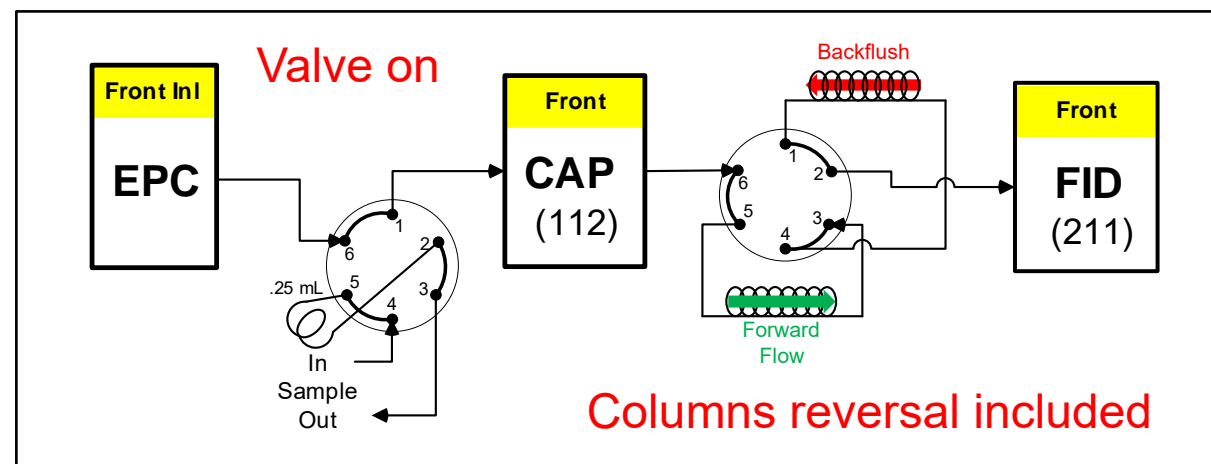
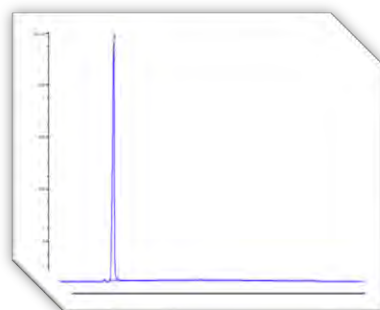
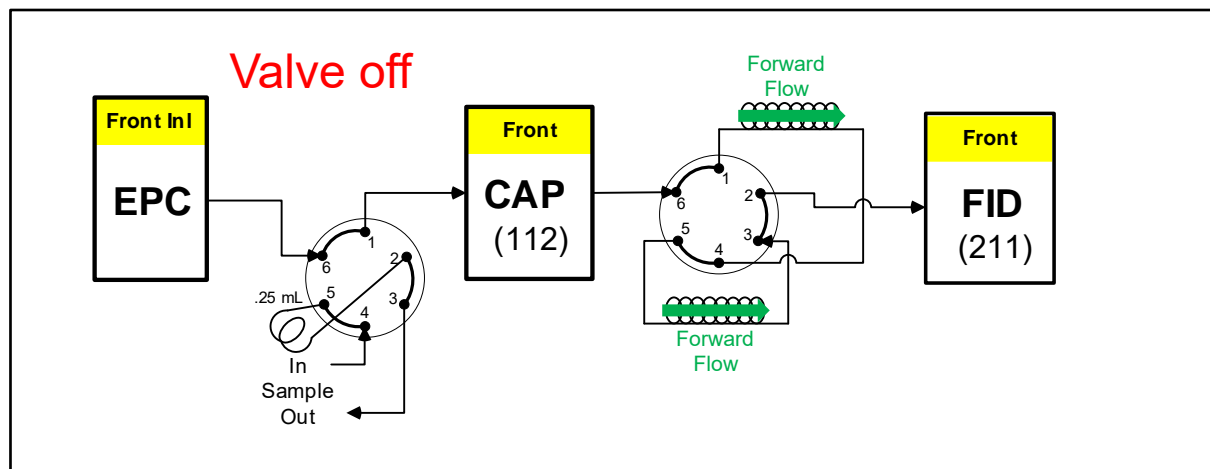



# Hydrocarbon Analysis

## Sample load

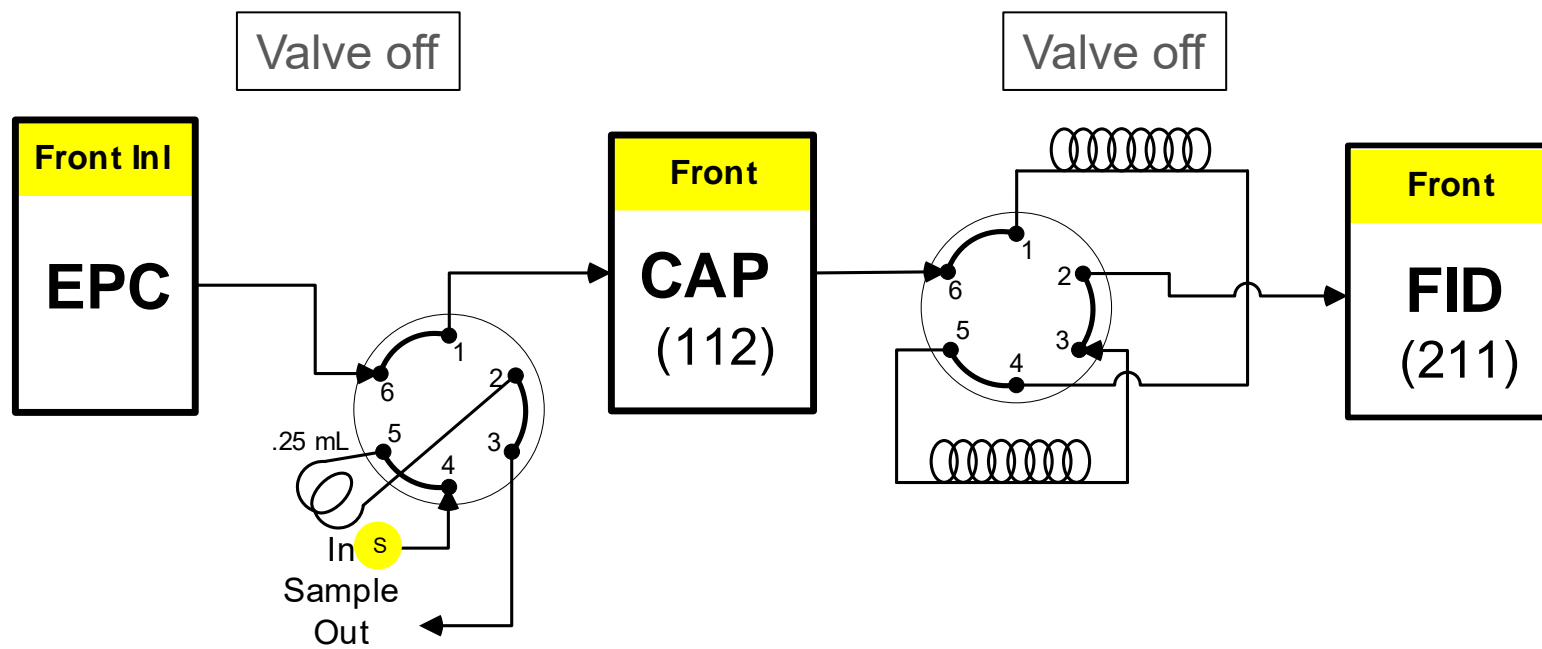

# Hydrocarbon Analysis

## Sample injection

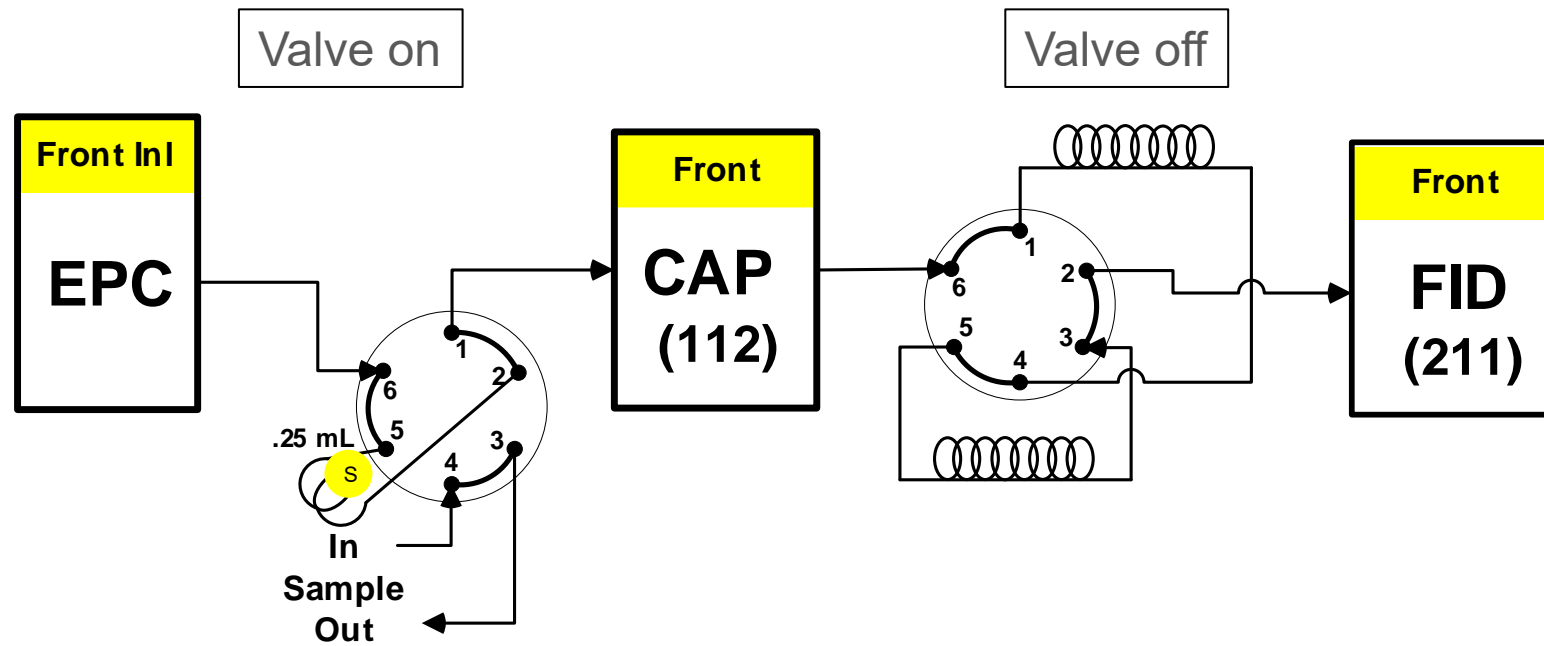

# Hydrocarbon Analysis

## Hexane plus initial separation

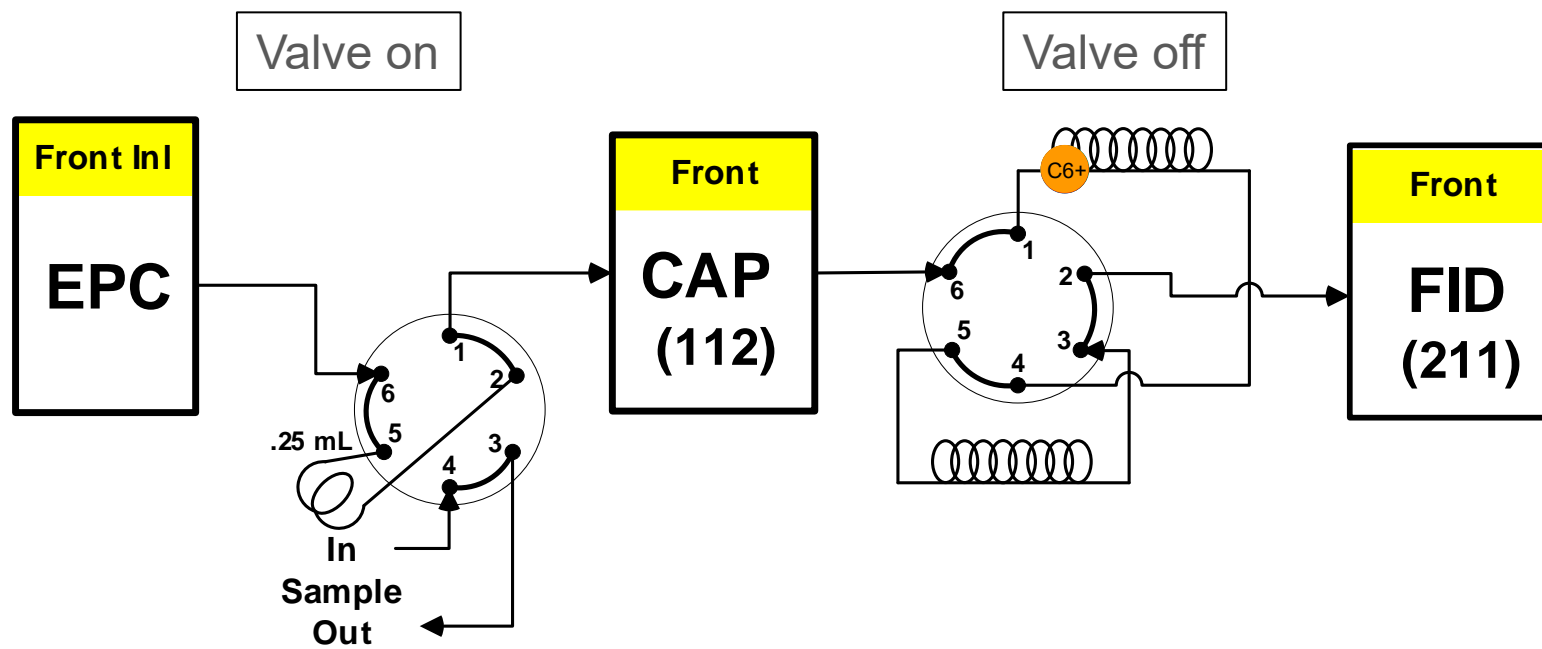

# Hydrocarbon Analysis

C6+, C1-C5 hydrocarbon elution to FID

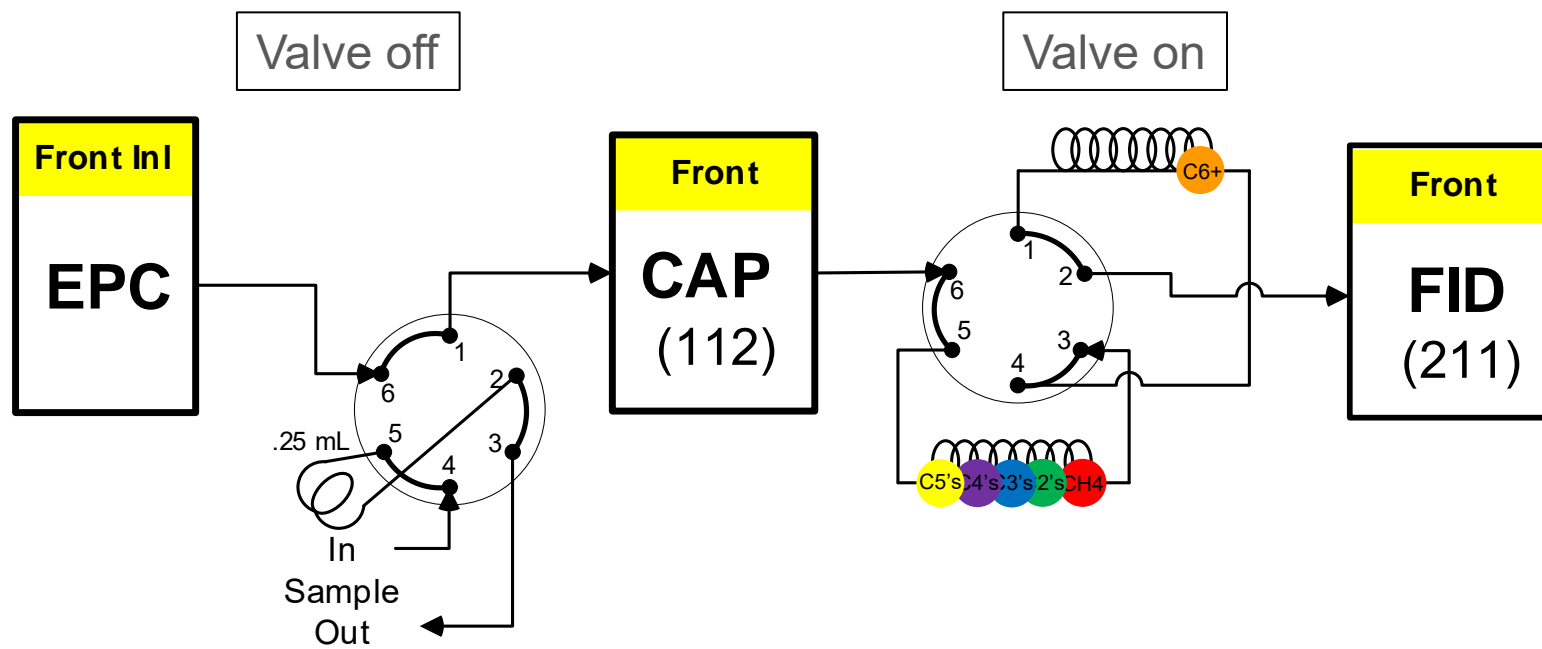

# Hydrocarbon Analysis

## Example chromatogram

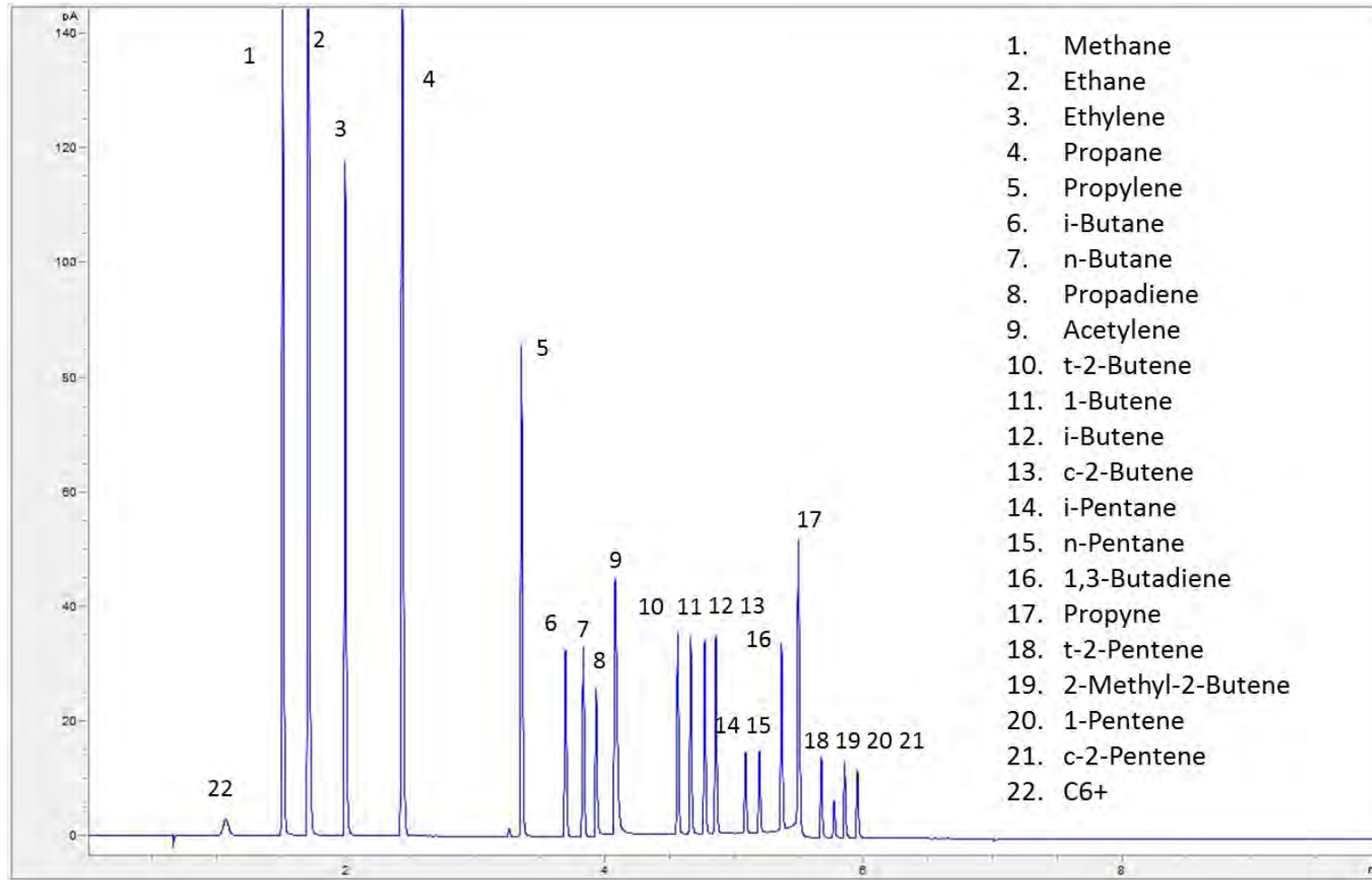

# Fast Refinery Gas Analysis

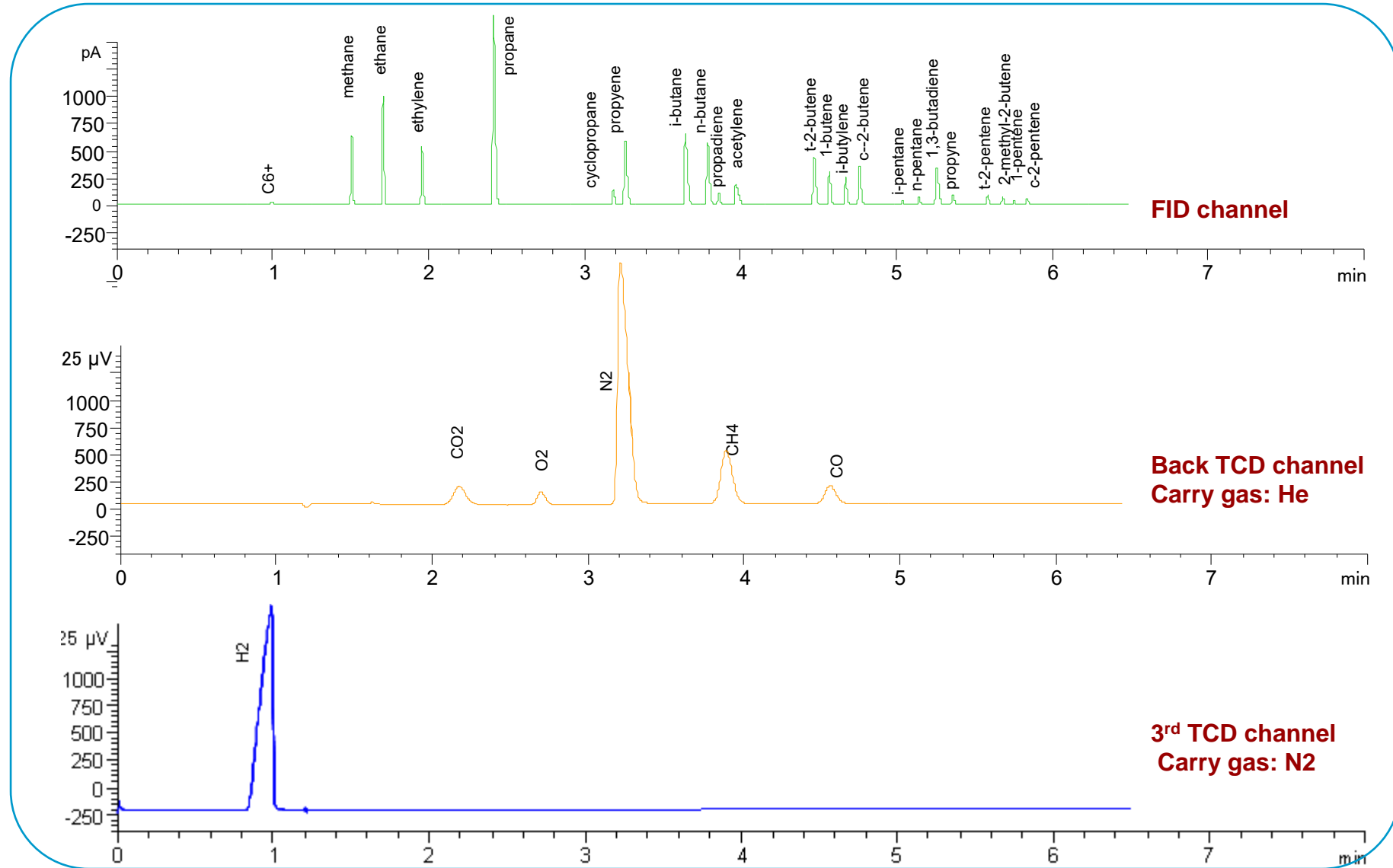

# Questions?

## Thank you!

