

Agilent CrossLab Start Up Services

Agilent G5574AA NGS Workstation Option B with ODTC Site Preparation Checklist



Thank you for purchasing an instrument from **Agilent Technologies**. CrossLab Start Up is focused on helping customers shorten the time it takes to start realizing the full value of their instrument investment.

Correct site preparation is the key first step in ensuring that your instruments and software systems operate reliably over an extended lifetime. This **checklist** outlines the supplies, space, and utility requirements for the system set up in your lab.

Introduction

Customer Information

- If you have questions or problems in providing anything described as part of *Customer Responsibilities* below, please contact your local Agilent or partner support / service organization for assistance prior to delivery.
- Agilent and/or its partners reserve the right to reschedule the installation dependent upon the readiness of your laboratory. Should your site not be ready for whatever reasons, please contact Agilent as soon as possible to re-schedule any services that have been purchased.
- Other optional services such as additional training, operational qualification (OQ) and consultation for user-specific applications can be ordered with the system but should be contracted separately.
- Be aware that all safety equipment will be installed unless Option #020 is specified on the sales order.

If Option #020 is specified, the Bravo [Safety and Liability Waiver Agreement for Stand-alone Sales without Safety Light Curtains](#) (part number D0006132) must be completed before the installation is completed. If an authorized customer representative does not sign this waiver and does not plan to implement their own Bravo safety protection, the Agilent Field Engineer may not install the Bravo Platform.

Customer Responsibilities

- Ensure that your site meets the following requirements before the installation date:

Site requirements for NGS Workstation Option B	Links to detailed specifications	Does your site meet the requirement?	
		Yes	No
Laboratory or bench space	Dimensions and Weight		
Environmental conditions	Environmental Conditions		
Number, type, and location of electrical outlets	Power Consumption		
Supplies for product installation and operation	Customer-Provided Supplies		
Additional requirements, laboratory bench specifications	Special Requirements and Other Considerations		
Computer and software requirements	Computer Specifications and Requirements		

- Locate your **sales order information**, software authorization codes, and/or software licenses/certificates.
- Provide availability of a system/network administrator as needed to connect to your intranet.
- While Agilent is delivering **Installation and Introduction** services, users of the instrument should be present throughout these services; otherwise, they will miss important operational, maintenance and safety information.
- If you cannot meet the requirements and responsibilities listed in this section, please contact Agilent as soon as possible to re-schedule any services that have been purchased.

Important Customer Web Links

- To access Agilent training and education, visit <http://www.agilent.com/chem/training> to learn about training options, which include online, classroom and onsite delivery. A training specialist can work directly with you to help determine your best options.
- To access the **Agilent Resource Center** web page, visit <https://www.agilent.com/en-us/agilentresources>. The following information topics are available:
 - Sample Prep and Containment
 - Chemical Standards
 - Analysis
 - Service and Support
 - Application Workflows
- The **Agilent Community** is an excellent place to get answers, collaborate with others about applications and Agilent products, and find in-depth documents and videos relevant to Agilent technologies. Visit <https://community.agilent.com/welcome>
- Videos about specific preparation requirements for your instrument can be found by searching the **Agilent YouTube** channel at <https://www.youtube.com/user/agilent>
- **Need to place a service call?** [Flexible Repair Options | Agilent](#)

Site Preparation

The following figures and table provide an overview of the hardware components.

Primary components (front view)

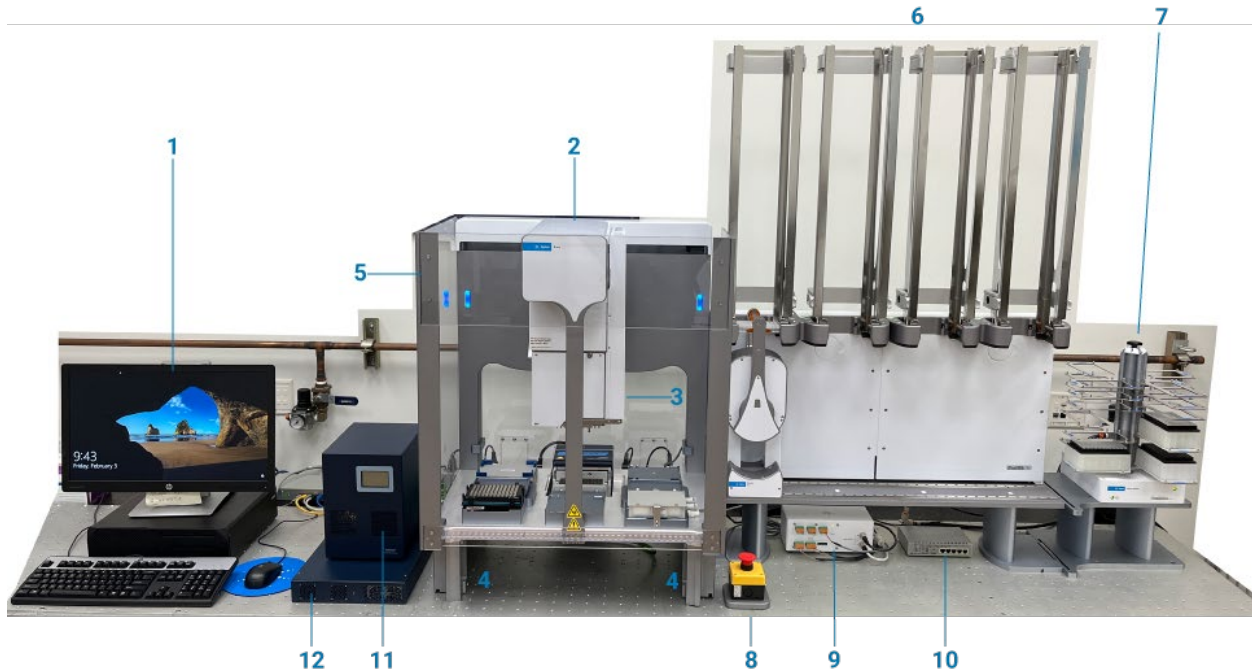

Item	Description
1	Computer and monitor
2	Bravo with Gripper assembly, specially configured deck for ODC accessory and deck risers (146 mm) (See following figure and table for accessories installed on deck.)
3	Bravo liquid-handling head (96LT Head, standard)
4	Bravo risers, 146 mm
5	Safety equipment, including Light Curtain and shields
6	BenchCel Microplate Handler 4R installed on risers (standard)
7	Labware MiniHub (installed on risers, standard)
8	Emergency-stop pendant
9	Robot Disable Hub
10	Ethernet switch

Item	Description
11	Inheco MTC controller (for Peltier Thermal Stations on Bravo deck)
12	ODTC Power & Control Unit
13	ThermoCube (not shown)
14	PlateLoc Thermal Microplate Sealer (standard, not shown)

Accessories installed on Bravo deck

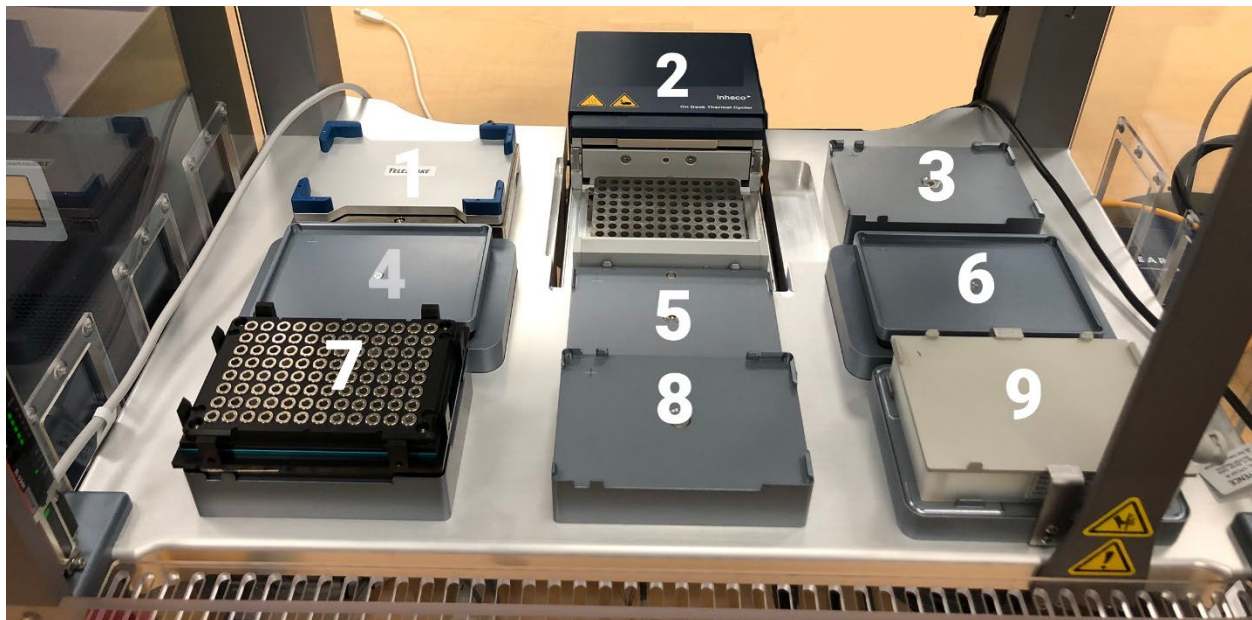

Deck location	Description
1	Orbital Shaking Station
2	ODTC (On-Deck Thermal Cycler)
3	Standard platepad
4	Peltier Thermal Station
5	Short platepad
6	Peltier Thermal Station
7	Magnetic Bead Accessory

Deck location	Description
8	Standard platepad
9	Thermal Station (cooling pad)

Dimensions and Weight

Identify the laboratory bench space before your system arrives based on the following table.

Pay special attention to the total height requirements for all system components you have ordered and avoid bench space with overhanging shelves. Also pay special attention to the total weight of the modules you have ordered to ensure your laboratory bench can support this weight.

Special notes

- The table surface must be at least 86 cm (34 in) from the floor to restrict reach-over access above the Light Curtain and shields.

WARNING Reaching over the Light Curtain and shields can expose operators to moving-parts hazards.

- The accessory tubing and cables are routed off the Bravo deck through the access windows in the Bravo side or read shields. The Bravo front opening is covered by top and bottom shields and the Light Curtain.
- This product requires additional lifting assistance due to its weight. Please discuss the arrangements for this activity with the service engineer prior to installation.
- **Do not store any objects below the Bravo deck.** Ensure that the airflow to and exhaust from the ODTc is unrestricted to prevent malfunction caused by insufficient cooling.

Instrument Description	Weight		Height		Depth		Width	
	Kg	lbs	cm	in	cm	in	cm	in
Workstation minimum dimensions ¹ (Includes only the Bravo, BenchCel, and MiniHub instruments)	125	276 ²	112	44	55	22	188	74
G5563A Bravo instrument on risers with Light Curtain	60.7	133.5	84.3	33.2	52.5	20.7	66.5	26.2
Bravo 96LT Head	3.83	8.5	20.3	8.0	18.4	7.25	10.5	4.13
G5580A BenchCel Microplate Handler with four 660-mm stacks								
with risers	-	-	126	50	20	8	86	34
without risers	49	107	112	44	20	8	86	34
G5584A Labware MiniHub								
with risers	-	-	55	22	38	15		15
without risers	11	24	37	15	38	15	138	15
Computer workstation with space for emergency-stop pendant	2.9	6.5	36.3	14.3	61.6	24.3	72.6	28.6
approx	approx							
ODTC	7.5	16.5	(Installed in Bravo deck location 2.)					
ODTC Power & Control Unit (PCU) ³	5.5	11	5.8	2.3	41.5	16.3	25.7	10.1
Orbital Shaking Station with Control Unit	2.2	4.9	(Installed in Bravo deck location 1.)					
Peltier Thermal Station (CPAC Ultraflat Heater/Cooler)	1	2.2	(Installed in Bravo deck locations 4 and 6.)					
Inheco MTC Controller ³	5.8	12.9	28	10.24	25.4	10	18.5	7.3
ThermoCube ³	13	28	32	13	32.4	12.8	30.5	12
Robot Disable Hub	1.36	3.0	9	3.5	11.4	4.5	22.5	8.8
G5585A PlateLoc Sealer (standalone, with roll of seal and open door) ⁴	20	45	58	23	40	16	22	9
<ol style="list-style-type: none"> In addition, you must plan space for the computer workstation, MTC Controller, ODTc PCU, and ThermoCube. Approximate: Includes additional weight to account for the accessories installed on the Bravo deck. The position of the MTC Controller, ODTc PCU, and ThermoCube may vary. However, the controllers must be placed within proximity of the Bravo deck to accommodate the reach of the cables and plumbing lines that connect to the accessories installed on the deck. The ThermoCube may be positioned underneath the table within 152 cm (5 feet) of the Thermal Station (cooling pad) to connect the tubing. For PlateLoc Sealer, see the PlateLoc Sealer site preparation checklist. 								

Figure. Overall NGS Workstation height (front view)

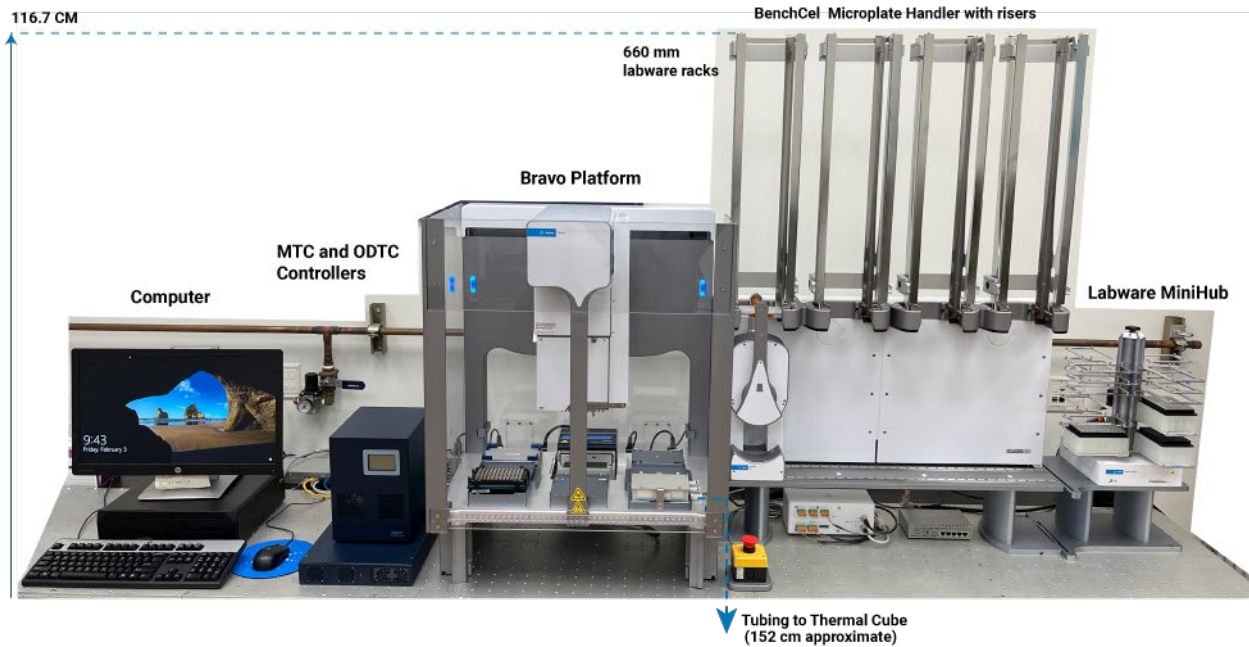
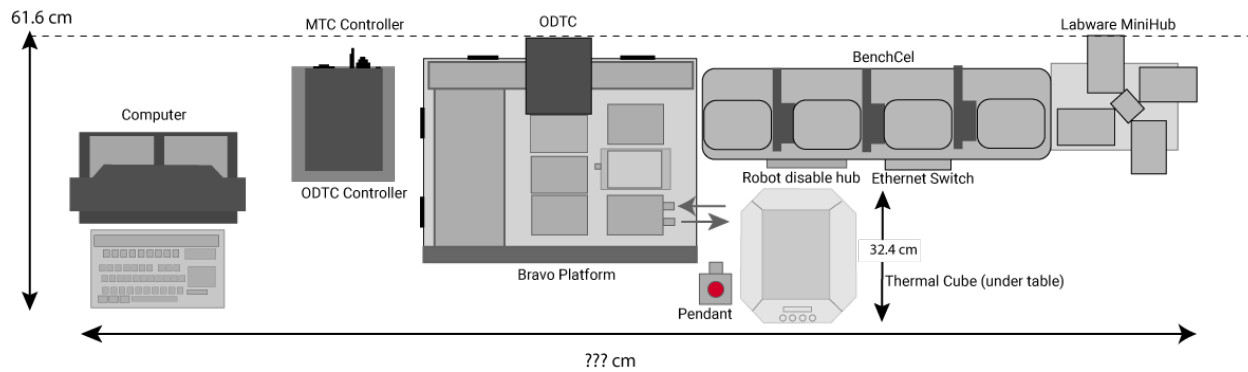
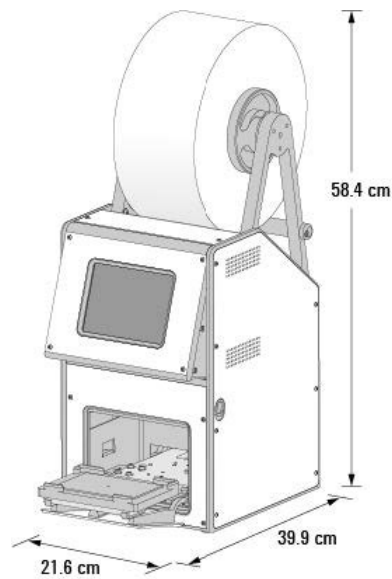

Figure. Overall NGS Workstation width and depth (top view)



Note: Allow approximately 155 cm (5 feet) for the total bench width.

Figure. PlateLoc Sealer dimensions



Environmental Conditions

Operating your instrument within the recommended temperature ranges ensures optimum instrument performance and lifetime.

Special notes

- Performance can be affected by sources of heat and cold, for example, direct sunlight, heating/cooling from air conditioning outlets, and drafts.
- The laboratory's ambient temperature conditions must be stable for optimum performance.
- The operation of the ODTG below ambient temperature must be limited to 1-2 hours per application. Depending on the humidity in the atmosphere, condensation may be generated when operating the ODTG below ambient temperature. Condensate can prevent the ODTG from operating properly and can damage the ODTG.
- The NGS Workstation Option B is intended to operate in a low-vibration environment. Excessive vibration may induce pipettor and robot errors.
- The NGS Workstation Option B is for indoor use only.

Operating Temperature °C	Operating Humidity %	Heat Dissipation BTU	Pollution degree	Installation category
4°C to 40°C	10-90% Relative Humidity, non-condensing	682.4 BTU/hour (200 W)	2	II

Power Consumption

Special notes

- Provide an appropriate power strip to accommodate power cords for up to 15 devices. Use the correct power cords, included with shipment.

The Orbital Shaking Station has a large plug that can occupy up to 3 sockets on a power strip unless it is plugged into the socket on the edge of the power strip.

- In addition to the following instruments, consider the power requirements of the computer workstation and accessories.
- If a computer system is supplied with your instrument, be sure to account for those electrical outlets.

Instrument Description	Line Voltage and Frequency (V, Hz)	Maximum Power Consumption (VA or W)
G5563A Bravo Platform	100-240 Vac, 50/60 Hz	1380-1440 W
G5580A BenchCel Microplate Handler	100-240 Vac, 50/60 Hz	5 A at 120 Vac 2.5 A at 240 Vac
G5584A Labware MiniHub	100-240 Vac, 50/60 Hz	150 VA
G5585A PlateLoc Sealer	North American model: 100-120 Vac, 50/60 Hz European model: 200-240 Vac, 50/60 Hz	4 A at 120 Vac 2.5 A at 240 Vac
Computer	100-240 Vac, 50/60 Hz	150 W
Orbital Shaker with Control Module	100-240 Vac, 50/60 Hz	-
MTC Controller	115 Vac, 60 Hz	-
ODTC Power & Control Unit	100-240 Vac, 50/60 Hz	1250 W

Instrument Description	Line Voltage and Frequency (V, Hz)	Maximum Power Consumption (VA or W)
Robot Disable Hub	100-240 Vac, 50/60 Hz	-
ThermoCube	100-240 Vac, 50/60 Hz	-

Required Operating Supplies by Customer for Installation

The customer must provide the following supplies for product installation and operation.

Item Description (including Dimensions etc.)	Part Number (if applicable)	Recommended Quantity
Coolant or process fluid, such as Koolance (27% propylene glycol/water mix) or 27% to 50% ethylene glycol/water mix for the Thermal Station (cooling pad) with ThermoCube	-	600 mL, approximately
Labware, such as microplates, automation lids, and reservoirs	various	various
Disposable 250 µL pipette tips, filtered, sterile https://www.agilent.com/en/product/automated-liquid-handling/consumables-for-lab-automation/bravo-lab-disposable-pipette-tips	Agilent 19477-002	Varies
Heat seal for the PlateLoc Sealer (standard) https://www.agilent.com/en/product/automated-liquid-handling/consumables-for-lab-automation/plateloc-microplate-heat-seals	Agilent seal (various)	Varies

Computer Requirements

Software specifications

- The NGS Workstation Option B with ODTc requires VWorks software 14.2. The following table lists the software specifications.

Specification Description	Minimum	Comments
Operating system name, version	Microsoft Windows 10, Enterprise or Professional, 64-bit (version 20H2)	This Windows build has been verified to work with VWorks 14.2. Ensure that Microsoft Windows is configured to Never Sleep. If the computer goes into Sleep mode, a computer restart might be required before VWorks can successfully log-in to OpenLab Shared Services.
O/S .NET and other add-ons	.NET 3.5 and .NET 4.7.2	If not already installed, the OpenLab for VWorks installer will automatically install the .NET components.
Web browser	One of the following: - Microsoft Edge - Internet Explorer 11 - Google Chrome 84 or later	The Content Browser in VWorks Plus requires a browser. A browser is required for viewing the VWorks Knowledge Base, which includes all the user guides.
Database software *	MySQL 8.0.1.18.0	MySQL is already installed on Agilent-supplied computers. MySQL is required only if you plan to use the VWorks Inventory database (for labware storage devices).
	PostgreSQL 11	PostgreSQL is automatically installed by the OpenLab for VWorks installer.
Antivirus software	Any of the following antivirus software: - Microsoft Security Essentials - McAfee - Symantec Endpoint Protection - Trend Micro	Agilent has tested the listed antivirus software for compatibility:
Language settings/compatibility	English	The VWorks software is available in English only.
Account settings/privileges	Domain user with local administrator privileges	Required for installation and configuration

* The *VWorks Automation Control Setup Guide* provides instructions on how to establish connections to the following VWorks databases, which are configured during installation.

- Experiments database (PostgreSQL)
- E-Signatures database (PostgreSQL)

Computer hardware specifications

- Ensure that the computer meets the following specifications or equivalent.

An Agilent-supplied computer, if purchased, is an HP Z2G4 or equivalent, with 16 GB RAM and meets all the following requirements.

Specification Description	Minimum
Processor type and speed	Intel i5, i7, or Xeon E3 equivalent 3.0 GHz or faster 64-bit 4 core
Memory (RAM)	16 GB
Internal storage/devices/media	500 GB hard drive capacity with 100 GB free space
Graphic resolution	1600 x 900 minimum 1920 x 1080 recommended
Display Scale and Layout	100% recommended
RS-232 port	1 serial port if the automation device requires a serial connection Alternatively, you may connect using a USB port with USB-to-serial adapter.
USB port	USB 2 Required for software installation via provided media. May be required to connect some devices or accessories.
LAN cards	100 MB/1 GB LAN for instrument control Second LAN card for lab intranet connection, if required Agilent-supplied computers are equipped with two Ethernet ports: 1 port to connect to the Workstation LAN via an Ethernet switch 1 port to connect to the customer's LAN IMPORTANT: Always verify the computer LAN connection to NGS Workstation Option B before connecting any other networks.

Special Requirements and Other Considerations

Laboratory table specifications

- The laboratory table must support the weight of the workstation without excessive shaking or movement. The table should be fixed in place, for example, castors that lock.
- The table must be level in the direction of the width and the depth of the platform. Using a traditional bubble level, the table should be leveled such that the bubble is centered between the two limit lines of the level
- The table surface must have a thickness relative to the material that will prevent warping when the workstation and computer are set upon the table.
- The table surface must be attached to the table frame.

Shipping container dimensions and weight

The following table lists the dimensions and weights of a couple of the largest and heaviest containers. The workstation shipment will include additional packages. Depending on the order, the shipping container dimensions and weights will vary. Ensure all doorways, hallways, floors, and elevators along the pathway to the installation site can accommodate the following containers.

Description	Weight		Height		Depth		Width	
	Kg	lbs	cm	in	cm	in	cm	in
BenchCel device and container	94	2047	67	26	66	26	107	42
Bravo container and pallet	85	187	100	41	67	27	87	34

Additional packages contain the pipette head, shields, light curtain, and accessories.

Note: Depending on the order, the shipment can include additional packages.

Compressed air requirement

The workstation requires the use of clean, dry, compressed air to move pneumatic components. The compressed air can be from a centralized source (house), compressed-air cylinders, or portable pumps. The air source must meet the following specifications:

Instrument	Quality	Flow rate	Pressure
BenchCel device	Clean, dry, compressed	34.0 Lpm (1.2 cfm)	0.65 to 0.69 MPa (95 to 100 psi)
PlateLoc Sealer	Clean, dry, compressed	70.8 Lpm (2.5 cfm)	0.62 to 0.69 MPa (90 to 100 psi)

CAUTION: Using oil compressors can cause oil to leak into the BenchCel Microplate Handler and void your warranty.

CAUTION: Air pressure greater than 0.69 MPa (100 psi) can damage the BenchCel Microplate Handler.

Safety equipment and precautions

WARNING! Changing or modifying the safety equipment can prevent the safe operation of the workstation, invalidate its safety compliance, and lead to personal injury or property damage. Any customer who does not use the supplied safety equipment or who modifies the supplied safety equipment assumes full responsibility for providing an appropriate level of safety for its operators and for providing the applicable safety compliance marking and documentation.

All safety equipment supplied with the instrument will be installed for you. The safety equipment includes an emergency-stop pendant (e-stop pendant), Light Curtain and shields. Ensure that operators understand the potential safety hazards and how to avoid them.

The [Automation Solutions Products General Safety Guide](#) (part number G5500-90015) and other safety guidelines are included in the shipment.

Service Engineer Review (Optional)

Service Engineer Comments

If the Service Engineer completed a review of the Site Preparation requirements with the customer, the Service Engineer should complete the following Comments section. Both the Service Engineer and the customer should complete the Site Verification section below.

If there are any specific points that should be noted as part of performing the service review or other items of interest for the customer, please write in this box.

Site Preparation Verification

Service Request Number:

Date of Review:

Service Engineer Name:

Customer Name:

Service Engineer Signature:

Total number of pages in this document: