

## **Agilent G5407A Labware Stacker Site Preparation Checklist**

Thank you for purchasing an Agilent G5407A **Labware Stacker**. To get you started and to assure a successful and timely installation, please refer to this specification or set of requirements.

Correct site preparation is the key first step in ensuring that your instruments and software systems operate reliably over an extended lifetime. This document is an **information guide AND checklist** prepared for you that outlines the supplies, consumables, space and utility requirements for your equipment for your site.

### **Customer Responsibilities**

**Make sure your site meets the following prior specifications before the installation date. For details, see specific sections within this checklist, including:**

- The necessary laboratory or bench space is available.
- The environmental conditions for the lab as well as laboratory gases and plumbing.
- The power requirements related to the product (e.g., number & location of electrical outlets).
- The required operating supplies necessary for the product and installation.
- Please consult Other Requirements section below for other product-specific information.
- For more details, please consult the **Labware Stacker and Rack-Handling User Guide** (part number G5407-90001).

**If Agilent is delivering installation and familiarization services, users of the instrument should be present throughout these services; otherwise, they will miss important operational, maintenance and safety information.**

### **Important Customer Information**

1. If you have questions or problems in providing anything described as a Customer Responsibilities above, please contact your local Agilent or partner support/service organization for assistance prior to delivery. In addition, Agilent and/or its partners reserve the right to reschedule the installation dependent upon the readiness of your laboratory.
2. Should your site not be ready for whatever reasons, please contact Agilent as soon as possible to re-arrange any services that have been purchased.
3. Other optional services such as additional training, operational qualification (OQ) and consultation for user-specific applications may also be provided at the time of installation when ordered with the system, but should be contracted separately.

**Agilent G5407A Labware Stacker  
Site Preparation Checklist**

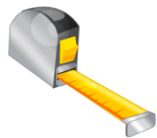

## Dimensions and Weight

Identify the laboratory bench space before your system arrives based on the table below.

Pay special attention to the **total height and total weight requirements for all system components you have ordered and avoid bench space with overhanging shelves**. Also pay special attention to the total weight of the modules you have ordered to ensure your laboratory bench can support this weight.

Instrument Description	Weight		Height		Depth		Width	
	Kg	lbs	cm	in	cm	in	cm	in
Labware Stacker device	5.3	11.6	21.6	8.5	19.7	7.8	21.7	8.6
Labware Rack (standard)*	2.3**	4.9**	68	26.8	13.3	5.3	8.9	3.5

\*The dimensions and weight are slightly different for different rack types.

\*\*The rack weight is for the front-loading rack and does not include liquid-filled microplates.

**Figure.** Dimensions of Labware Stacker with standard labware rack

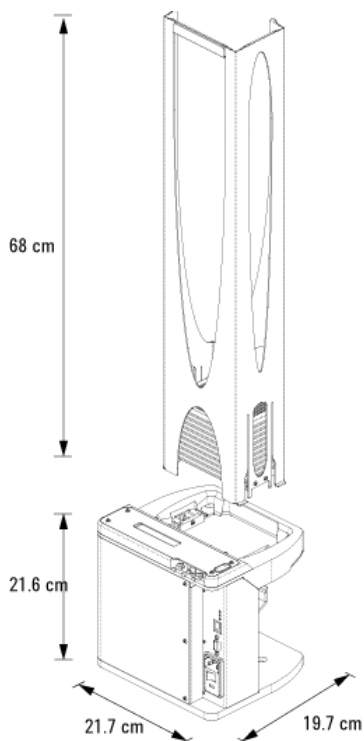

**Agilent G5407A Labware Stacker  
Site Preparation Checklist**

## Environmental Conditions

Operating your instrument within the recommended temperature ranges ensures optimum instrument performance and lifetime.

### Special Notes

1. Performance can be affected by sources of heat & cold e.g. direct sunlight, heating/cooling from air conditioning outlets, drafts and/or vibrations. The site's ambient temperature conditions must be stable for optimum performance.
2. The Labware Stacker is for indoor use only.

Instrument Description	Operating temp range °C (F)	Operating humidity range (%)	Pollution degree	Installation category
Labware Stacker	4 to 40 °C	10% to 95% RH, non- condensing	2	II



## Power Consumption

### Special Notes

1. If a computer system is supplied with your instrument, be sure to account for those electrical outlets.

Instrument Description	Line Voltage & Frequency (V, Hz)	Maximum Power Consumption (VA)	AC Fuse
Labware Stacker	110–240 VAC @ 50/60 Hz	1.2A/120V or 72A/240V (typical)	1 A, 250V, 5x20 mm, Slo-Blo

**Agilent G5407A Labware Stacker  
Site Preparation Checklist**

**Required Operating Supplies by Customer**
**Special Notes**

Item Description (including dimensions etc)	Vendor's Part Number (if applicable)	Recommended Quantity
<p><b>Compressed air:</b></p> <p>The Labware Stacker requires the use of clean, dry, compressed air to move pneumatic components inside the device. The compressed air can be from a centralized source (house), compressed-air cylinders, or portable pumps.</p> <p><b>CAUTION</b> Using oil compressors can introduce oil into the device and void your warranty.</p> <p>Air requirements:</p> <ul style="list-style-type: none"> <li><input type="checkbox"/> Quality: Clean, dry, compressed</li> <li><input type="checkbox"/> Flow rate: &lt;28.3 Lpm (1.0 cfm)</li> <li><input type="checkbox"/> Pressure: 0.35 to 0.55 MPa (50 to 80 psi)</li> </ul>		

## Agilent G5407A Labware Stacker Site Preparation Checklist



### Other Requirements

#### Computer Requirements

The Labware Stacker requires an Ethernet port for a local area network (LAN) connection:

- One network card if the controlling computer will not be connected to your organization's LAN.
- Two network cards if the controlling computer will be connected to your organization's LAN in addition to the Labware Stacker LAN.

**WARNING:** Connecting the Labware Stacker to a company or general network can cause potential injury. Remote computer operators might accidentally initiate an operation that causes the Stacker gripper to move unexpectedly, possibly injuring nearby lab personnel. Avoid connecting the Stacker to a company or general network.

Additional requirements depend on the lab automation software you are using:

- For VWorks software and Stacker ActiveX Control, see the software release notes or the Automation Solutions Knowledge Base at [www.agilent.com/lifesciences/automation](http://www.agilent.com/lifesciences/automation).
- For third-party automation software, see the user documentation supplied with the product.

#### Important Customer Web Links

- For additional information about Agilent automation solutions, please visit our web site at <http://www.agilent.com/en-us/products/automation-solutions>
- Need to get information on your product?
  - VWorks **Knowledge Base** - <http://www.agilent.com/chem/askb>
  - Literature Library - <http://www.agilent.com/en-us/library/literature>
- Need to know more? [www.agilent.com/chem/education](http://www.agilent.com/chem/education)
- Need technical support? [www.agilent.com/crosslab](http://www.agilent.com/crosslab)

Document part number: G5407-90004