

Agilent CrossLab Start Up Services

Agilent G5563A, G5563AA/GA, G5562A, G5296AA/GA Bravo Platform Site Preparation Checklist



Thank you for purchasing an instrument from **Agilent Technologies**. CrossLab Start Up is focused on helping customers shorten the time it takes to start realizing the full value of their instrument investment.

Correct site preparation is the key first step in ensuring that your instruments and software systems operate reliably over an extended lifetime. This document is an **information guide and checklist** prepared for you that outlines the supplies, space, and utility requirements for the system set up in your lab.

Introduction

Customer Information

- If you have questions or problems in providing anything described as part of *Customer Responsibilities* below, please contact your local Agilent or partner support / service organization for assistance prior to delivery. In addition, Agilent and/or its partners reserve the right to reschedule the installation dependent upon the readiness of your laboratory.
- Should your site not be ready for whatever reasons, please contact Agilent as soon as possible to re-schedule any services that have been purchased.
- Other optional services such as additional training, operational qualification (OQ) and consultation for user-specific applications may also be provided at the time of installation when ordered with the system but should be contracted separately.
- Please refer to the other peripheral products (ie, samplers etc.) for site preparation requirements.
- Be aware that all Bravo safety equipment will be installed unless Option #020 is specified on the sales order.
 - If Option #020 is specified, the *Bravo Safety and Liability Waiver Agreement for Stand-alone Sales without Safety Light Curtains* (part number D0006132) must be completed before the Bravo installation is completed. If an authorized customer representative does not sign this waiver and does not plan to implement their own Bravo safety protection, the Agilent Field Engineer may not install the Bravo Platform.
 - For a description of the potential hazards, see the following guides:
Bravo Platform Safety and Installation Guide (part number G5563-90002)
Automation Solutions Products General Safety Guide (part number G5500-90015)

Changing or modifying the Bravo Platform safety equipment may prevent the safe operation of the Bravo Platform, invalidate its safety compliance, and lead to personal injury or property damage. Any customer who does not use the supplied safety equipment or who modifies the supplied safety equipment assumes full responsibility for providing an appropriate level of safety for its operators and for providing the applicable safety compliance marking and documentation.

Customer Responsibilities

Ensure that your site meets the following specifications before the installation date.
For details, see specific sections within this checklist, including:

| Site requirements for the AssayMAP Bravo Platform | Links to detailed specifications | Does your site meet the requirement? | |
|---|---|--------------------------------------|----|
| | | Yes | No |
| Laboratory or bench space | Dimensions and Weight | | |
| Environmental conditions | Environmental Conditions | | |
| Number, type, and location of electrical outlets | Power Consumption | | |
| Supplies for product installation and operation | Required Operating Supplies | | |
| Additional laboratory bench specifications, computer requirements, and safety equipment | Special Requirements and Other Considerations | | |

- Locate your **sales order information**, software authorization codes, and/or software licenses/certificates.

Note: Two licenses for VWorks Standard 14.4 are included with each Bravo purchase. One license is for the computer that runs the Bravo Platform. The second license may be installed on a second computer, for example, for VWorks protocol development.

- Provide availability of a system/network administrator as needed to connect to your intranet.
- While Agilent is delivering **Installation and Introduction** services, users of the instrument should be present throughout these services; otherwise, they will miss important operational, maintenance and safety information.

Important Customer Web Links

- To access Agilent training and education, visit <http://www.agilent.com/chem/training> to learn about training options, which include online, classroom and onsite delivery. A training specialist can work directly with you to help determine your best options.
- To access the **Agilent Resource Center** web page, visit <https://www.agilent.com/en-us/agilentresources>. The following information topics are available:
 - Sample Prep and Containment
 - Chemical Standards
 - Analysis

- Service and Support
- Application Workflows
- The **Agilent Community** is an excellent place to get answers, collaborate with others about applications and Agilent products, and find in-depth documents and videos relevant to Agilent technologies. Visit <https://community.agilent.com/welcome>
- Videos about specific preparation requirements for your instrument can be found by searching the **Agilent YouTube** channel at <https://www.youtube.com/user/agilent>
- **Need to place a service call?** [Flexible Repair Options | Agilent](#)

Site Preparation

Dimensions and Weight

Identify the laboratory bench space before your system arrives based on the table below. Pay special attention to the total height and total weight requirements for all system components you have ordered and avoid bench space with overhanging shelves. Also pay special attention to the total weight of the modules you have ordered to ensure your laboratory bench can support this weight.

Special notes

- The table surface must be at least 86 cm (34 in) from the floor to restrict reach-over access above the Light Curtain and shields.

Ensure that the table surface is high enough to prevent operators from reaching over the Light Curtain and shields, which can expose operators to moving-parts hazards.

- In addition to the dimensions of the Bravo Platform, you should plan space for the Pump Module, if applicable, and the computer workstation.
- See additional laboratory bench specifications under Other Requirements.
- This product requires additional lifting assistance due to its weight. Please discuss the arrangements for this activity with the service engineer prior to installation.

| Instrument Description | Weight | | Height | | Depth | | Width | |
|--|--------|-------|--------|-------|-------|------|-------|------|
| | Kg | lbs | cm | in | cm | in | cm | in |
| G5563A Bravo (Standard) | 52.1 | 114.9 | 69.7 | 27.4 | 43.8 | 17.2 | 64.8 | 25.5 |
| G5563A Bravo with Standard Light Curtain | 60.7 | 133.5 | 70.2 | 27.64 | 48.3 | 19.0 | 67.1 | 26.4 |
| G5563A Bravo with Wraparound Light Curtain | 61.9 | 136 | 69.7 | 27.45 | 47.4 | 18.8 | 78.0 | 30.7 |
| G5563A Bravo with Bravo Risers | — | — | 84.3 | 33.2 | — | — | — | — |
| G5563AA/GA Bravo (Standard) with ODC | — | — | 69.7 | 69.7 | 58.8 | 23.2 | 64.8 | 25.5 |
| G5562A Bravo (SRT) | 51.5 | 113.5 | 61.7 | 24.3 | 43.8 | 17.2 | 64.8 | 25.5 |
| G5562A Bravo with Standard Light Curtain | 60.1 | 132.5 | 61.7 | 24.3 | 52.5 | 20.7 | 66.5 | 26.2 |
| G5562A Bravo with Wraparound Light Curtain | 61.3 | 135 | 61.7 | 24.3 | 47.4 | 18.7 | 78.0 | 30.7 |
| G5562A with Bravo Risers | — | — | 76.3 | 30 | — | — | — | — |

The following figures show the dimensions of the Bravo without risers installed.

Dimensions of G5563A Bravo (left) G5563AA/GA (center) and G5562A SRT Bravo (right)

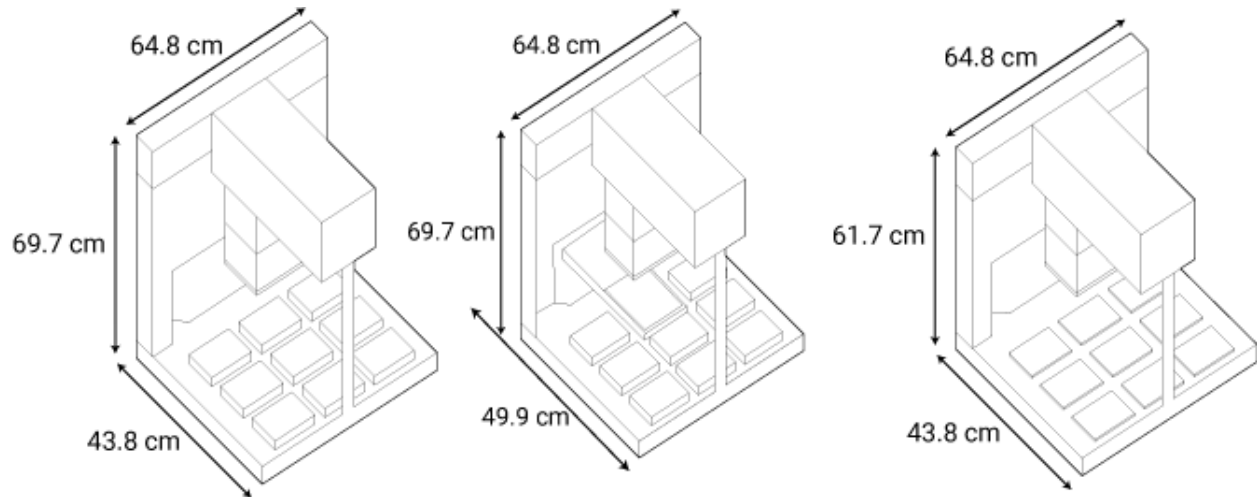

Dimensions of G5563A Bravo on Risers with Standard Light Curtain and Shields

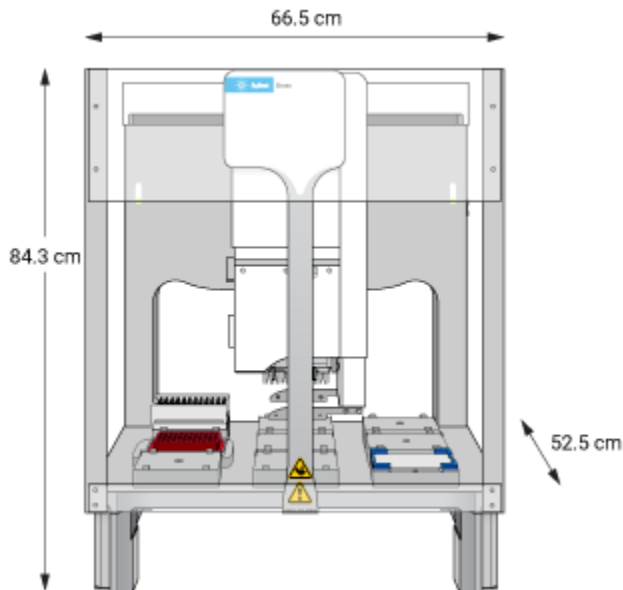

Environmental Conditions

Operating your instrument within the recommended temperature ranges ensures optimum instrument performance and lifetime.

Special notes

- Performance can be affected by sources of heat and cold, for example, direct sunlight, heating/cooling from air conditioning outlets, drafts, and/or vibrations. The laboratory's ambient temperature conditions must be stable for optimum performance.
- The Bravo Platform is intended to operate in a low-vibration environment. Excessive vibration may induce pipettor and robot errors.
- The Bravo Platform is for indoor use only.

| Operating Temperature Range °C (F) | Operating Humidity Range (%) | Heat Dissipation (BTU) | Pollution Degree | Installation Category |
|------------------------------------|------------------------------|---------------------------|------------------|-----------------------|
| 4 to 40 °C | 10 % to 90% | 682.4 BTU/hour (200 W) | 2 | II |

Power Consumption

Special notes

- If a computer system is supplied with your instrument, be sure to account for those electrical outlets.
- Use the correct power cord.

| Instrument Description | Line Voltage and Frequency V, Hz | Maximum Power Consumption VA | Fuse (AC entry) |
|--|-------------------------------------|---------------------------------|--------------------------------------|
| G5563A/G5563AA/GA/G5562A Bravo Platform | 100-240V & 50/60 Hz | 300 | 250 V, 6.3A, 5 x 20-mm, slow blow |

Required Operating Supplies by Customer for Installation

| Item Description (including Dimensions etc.) | Vendor's Part Number (if applicable) | Recommended Quantity |
|---|---|-------------------------|
| Pipette tips, disposable https://www.agilent.com/en/product/automated-liquid-handling/consumables-for-lab-automation/bravo-lab-disposable-pipette-tips | Agilent | varies |
| Labware https://www.agilent.com/en/product/microplates Note: Requirements may vary depending on experiment design. | varies | varies |

Special Requirements and Other Considerations

Laboratory Table Specifications

- The laboratory table must support the weight of the Bravo Platform without excessive shaking or movement. The table should be fixed in place, for example, castors that lock.
- The table must be level in the direction of the width and the depth of the platform. Using a traditional bubble level, the table should be leveled such that the bubble is centered between the two limit lines of the level
- The table surface must have a thickness relative to the material that will prevent warping when the Bravo Platform and computer are set upon the table.
- The table surface must be attached to the table frame.

Computer Requirements

The computer requirements vary depending on the VWorks software version.

- For VWorks Software 14.4 requirements, refer to the *VWorks Software 14.4 Site Preparation Checklist*.
- For VWorks Software 13.1.x requirements, refer to the software release notes.

Service Engineer Review (Optional)

Service Engineer Comments

If the Service Engineer completed a review of the Site Preparation requirements with the customer, the Service Engineer should complete the following Comments section.

If there are any specific points that should be noted as part of performing the service review or other items of interest for the customer, please write in this box.

Site Preparation Verification

Service Request Number:

Date of Review:

Service Engineer Name:

Customer Name:

Service Engineer Signature:

Total number of pages in this document: