

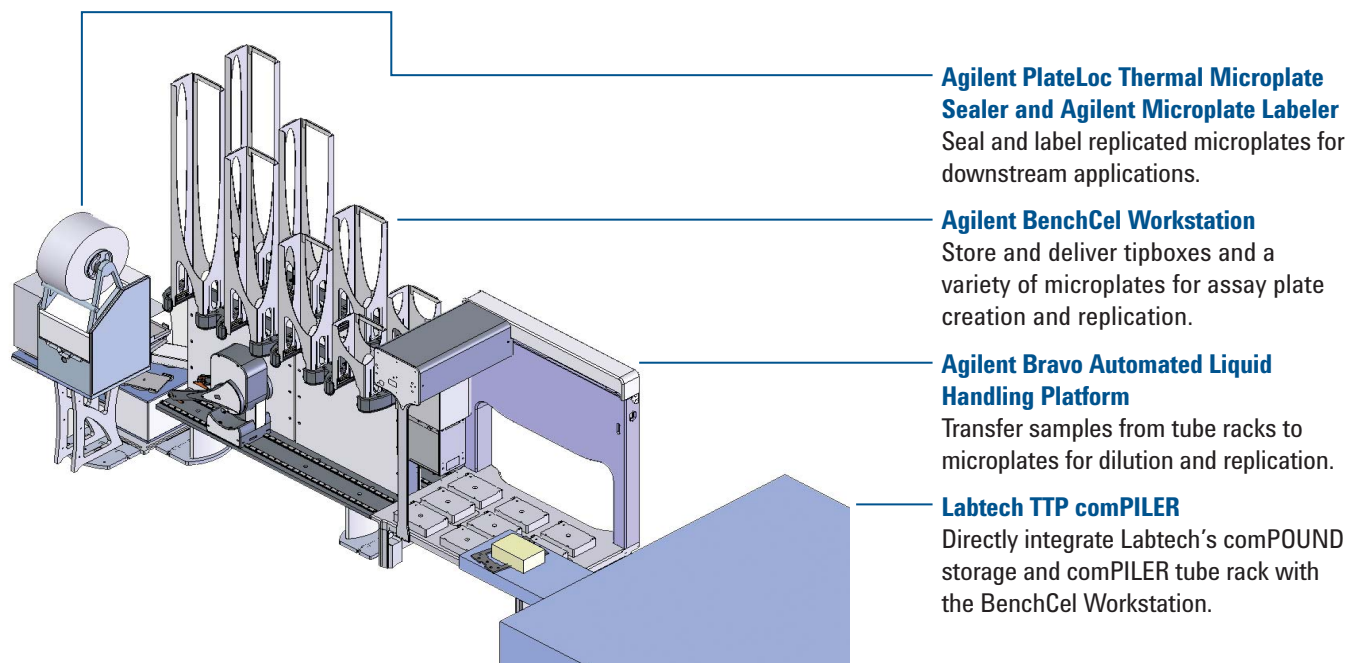

Agilent Automation Integration Highlight

TTP Labtech comPOUND/comPILER Integration



Agilent PlateLoc Thermal Microplate Sealer and Agilent Microplate Labeler
Seal and label replicated microplates for downstream applications.

Agilent BenchCel Workstation
Store and deliver tipboxes and a variety of microplates for assay plate creation and replication.

Agilent Bravo Automated Liquid Handling Platform
Transfer samples from tube racks to microplates for dilution and replication.

Labtech TTP comPILER
Directly integrate Labtech's comPOUND storage and comPILER tube rack with the BenchCel Workstation.

A Benchtop Solution:

Agilent Automation's BenchCel Workstations provide complete automation for microplate replication and assay plate generation.

The integration of the Bravo Automated Liquid Handling Platform to the TTP comPILER allows for a comprehensive solution for the generation of assay plates and replicates from samples stored in comPOUND storage systems. The addition of the BenchCel Workstation, PlateLoc Thermal Microplate Sealer and Microplate Labeler provide a complete walk-away solution for compound management.

The integration of Agilent VWorks with TTP Labtech's control software allows researchers to request a variety of assay plates to be processed from stored compounds without user intervention.

Agilent Automation Benefits:

- **Plate Handling:** Use 96-, 384- and 1536-well microplates and lids.
- **Scalability:** Additional BenchCel stacks or units can increase capacity and throughput as needed.
- **Flexibility:** Bravo's on-deck accessories simplify tip washing, repeated liquid transfers, shaking, barcode reading, and more.
- **Throughput:** The Bravo Automated Liquid Handler can transfer samples to two replicate plates in less than two minutes.
- **Intelligent:** VWorks Automation Control software schedules protocol tasks and incubation steps, and maintains reagent order-of-addition. Capable of LIMS or database integration, barcode tracking, and tracking various tasks in relation to individual plates.



Agilent Technologies



Assay plate requests sent to TTP comPOUND system

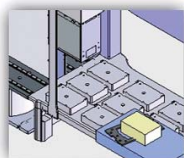

Processed sample tube racks are delivered to Agilent BenchCel Workstation

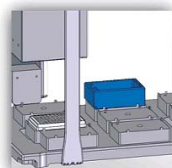

Workstation transfers samples to assay plates according to assay plate request

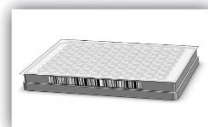

Sealed and barcode labeled assay plates are transferred to BenchCel storage racks

Example workflow for the TTP Labtech Integration with the Agilent BenchCel Workstation. Individual steps can be modified to meet application requirements.

Configuration Options

The Agilent BenchCel Workstation offers the flexibility of adding and reconfiguring options to meet your workflow requirements.

- **Capacity:** Upgrade to a 6-stack BenchCel Microplate Handler or add another BenchCel Microplate Handler to increase capacity.
- **Flexibility:** Agilent Automation Solutions provides expertise with proven integration of a variety of devices including bulk dispensers, plate washers, microplate readers, and more to meet your application requirements.
- **Agilent Bravo Accessories:** The Bravo Automated Liquid Handling Platform offers a variety of accessories including Auto-filling Reservoirs, Tip Wash Stations, Evaporation Stations, Vacuum Filtration, and more.
- **More:** Speak with one of our product specialists or application specialists to determine what configuration will work best for you.

Additional Services

All BenchCel Workstations include installation and product familiarization along with options to purchase additional services to meet your specific needs.

These options include:

- **Consulting:** Work with a team of experts to determine the best solution for your laboratory.
- **Application Development:** Let our application specialists develop and test system protocols for your applications.
- **More:** Speak with one of our product specialists regarding any additional support you require to ensure our solution meets all of your needs.

www.agilent.com/lifesciences/automation

Agilent Technologies shall not be liable for errors contained herein or for incidental or consequential damages in connection with the furnishing, performance, or use of this material.

Information, descriptions, and specifications in this publication are subject to change without notice.

© Agilent Technologies, Inc. 2009
Published in the USA
October 22, 2009
5990-4526EN



Agilent Technologies