

DS 302 Rotary Vane Pump

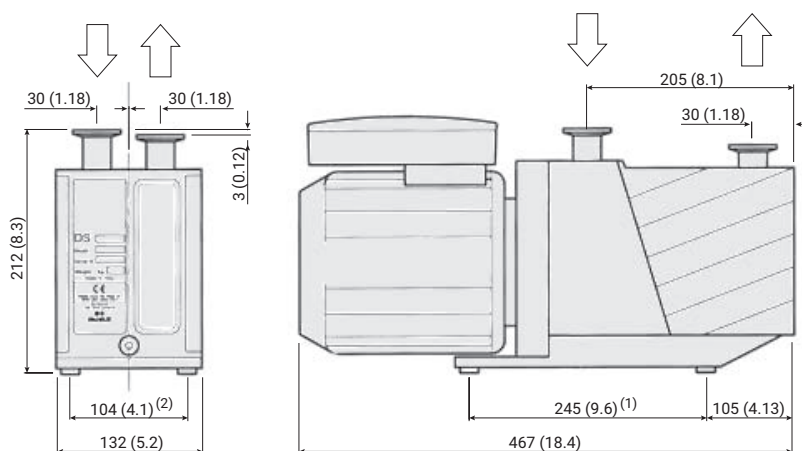

Alternative mounting holes are also available,
 with (1) = 226 (8.9) and (2) = 98 (3.8), with hole $\varnothing = 7$ (0.3)

Dimensions: millimeters (inches)

The DS 302 is a dual-stage oil-sealed rotary vane pump that delivers a pumping speed of 11.6 m³/h at 50 Hz, or 8.2 CFM at 60 Hz, and a base pressure of $<2 \times 10^{-3}$ mbar. The DS 302 operates at a very quiet sound pressure, with a universal-voltage single-phase electric motor, with integral power switch.

An inlet isolation valve is integrated into the pump to close off the inlet port whenever power to the pump is interrupted. This antibackstream valve retains vacuum in the roughing, or foreline, and prevents pump oil from contaminating the vacuum chamber. The DS 302 has a manual gas ballast valve, which when opened, allows the pump to achieve its rated water vapor handling specification.

Technical specifications

Free Air Displacement	60 Hz: 285 L/min (10 cfm)	50 Hz: 237 L/min (14.2 m ³ /h)
Pumping Speed*	60 Hz: 8.2 cfm	50 Hz: 11.6 m ³ /h
Ultimate Partial Pressure*	10 ⁻⁴ mbar	
Ultimate Total Pressure*	2 × 10 ⁻³ mbar	
Ultimate Total Pressure With Gas Ballast*	2 × 10 ⁻² mbar	
Water Vapor Tolerance	20 mbar	
Water Vapor Capacity	160 g/h	
Oil Capacity Min/Max	0.25/0.6 L	
Motor Rating 1 ph	60 Hz: 0.72 kW	50 Hz: 0.72 kW
Nominal Rotation Speed	60 Hz: 1,800 rpm	50 Hz: 1,500 rpm
Weight	25 kg (55 lb)	
Inlet Flange	DN 25 ISO-KF	
Exhaust Flange	DN 25 ISO-KF	

* According to PNEUROP 6602

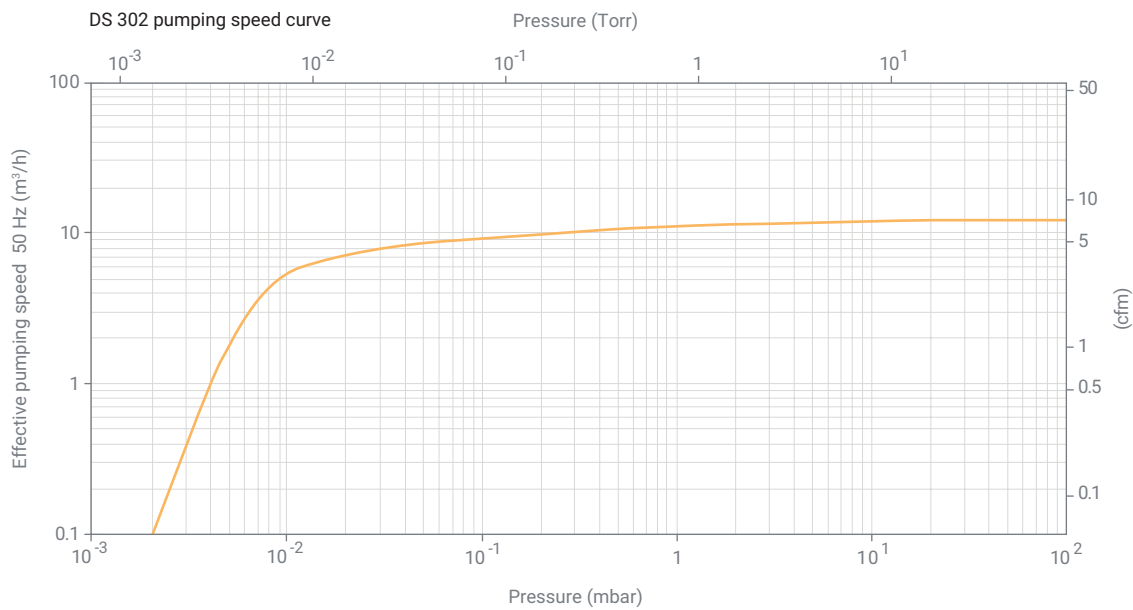

Ordering information

Description	Part Number
Dual Stage Rotary Vane Pump: DS 302 with 1 Phase Worldwide Motor* * 1-phase motors (100 to 120/200 to 230) V \pm 10%, 50/60 Hz. All motors comply with CE and UL/CSA standards.	9499325
Maintenance Kits	
Minor Maintenance Kit: Contains all the Valves, O-rings, and Seals to Refurbish the Pump to Vacuum Integrity	9499370
Major Maintenance Kit: Includes all the Items of the Minor Kit Plus the Vanes	9499381
Oil and Accessories	
Rotary Vane Fluid, DS19 Type, 1 Liter	9499390
Rotary Vane Fluid, DS19 Type, 1 Liter (USA)*	K7516301
Rotary Vane Fluid, DS19 Type, 1 Gallon (USA)	K7516302
Oil Mist Eliminator	9499395
Oil Mist Replacement Cartridge (Pkg. of 2)	9499394
NW 25 Oil Exhaust Filter	9499392
NW 25 Oil Exhaust Replacement Cartridge	9499342
Oil Return Kit	9499376
Oil Drain Extension	9499375
European Plug Power Cable 2 Meters 1 ph	9499396
USA Plug Power Cable 2 Meters 1 ph	9499397
UK Plug Power Cable 2 Meters 1 ph	9499398
NW 25 Centering Ring Viton	KC25AV
NW 25 Aluminum Clamp	KQ25AWP

* When these pumps are used in Leak Detectors applications, we recommend the use of Rotary Vane Fluid (Elite-Z mechanical, part number 695409005) as it features a lower vapor pressure.

Contact information

Americas

Agilent Technologies
121 Hartwell Avenue,
Lexington, MA 02421 USA
Toll free: +1 800 882 7426
vpl-customer@agilent.com

Europe, Middle East, Africa, India

Agilent Technologies Italia SpA
Via F.lli Varian 54,
10040 Leini (Torino), Italy
Tel: +39 011 9979 111
Toll free: 00 800 234 234 00
vpt-customer@agilent.com

China

Beijing Office Agilent Technologies
(China) Co. Ltd.
No.3, Wang Jing Bei Lu,
Chao Yang District,
Beijing, 100102, China
Toll free: 800 820 6778
Contacts.vacuum@agilent.com

For more information, please contact your Agilent representative or visit www.agilent.com/chem/vacuum where you can chat live with a vacuum expert.



[www.agilent.com/en/
product/vacuum-technologies/oil-
sealed-rotary-vane-pumps/dual-
stage-ds-rotary-vane-pumps/ds-302-
rotary-vane-pump](http://www.agilent.com/en/product/vacuum-technologies/oil-sealed-rotary-vane-pumps/dual-stage-ds-rotary-vane-pumps/ds-302-rotary-vane-pump)

DE44337.2679282407

This information is subject to change without notice.

© Agilent Technologies, Inc. 2021, 2023
Printed in the USA, April 3, 2023
5994-3542EN

