



Agilent 1260 Infinity Nanoflow LC System for Mass Spectrometry (MS) G2229A

Quick Start Guide

In this guide

Stacking the System	2
Preparing the System	4
Checkout Procedure	6
Operation - Tips and Hints	10
Part Information	12

Use this guide to install your Agilent Nanoflow LC System for MS.

This guide also provides valuable tips and hints for operation of the system. Following these hints will ensure a successful run.

If you need to reorder parts please refer to the tables on the rear page.



Agilent Technologies

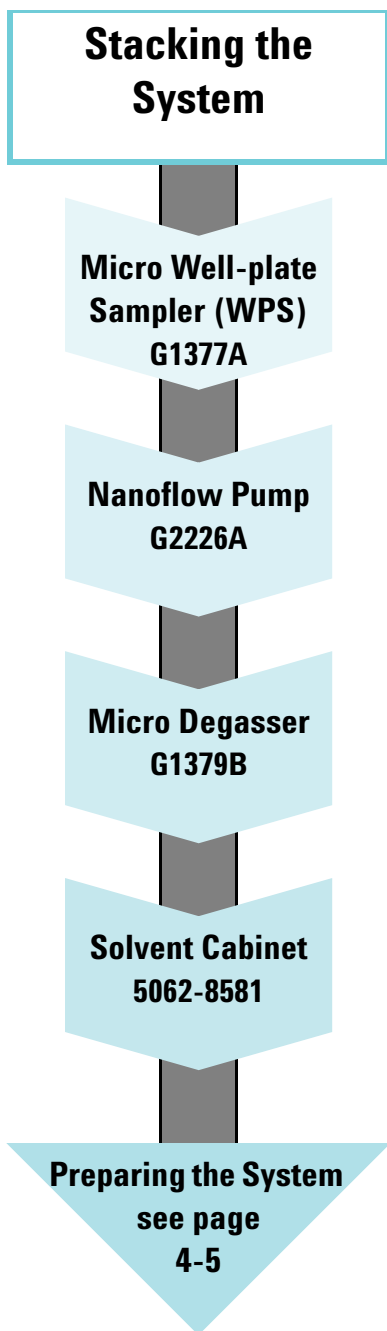

Installation Step

How to Proceed

Unpack and install the WPS

- Place the Micro Well-plate Sampler on the bench
- Remove the ST safety foam
- Connect the power cable
- Connect the corrugated waste tube to the seat adapter and the solvent waste port from the leak plane

Unpack and install the nanoflow pump

- Place the nanoflow pump on top of the WPS
- Connect the CAN cable between the pump and the WPS
- Connect the power cable
- Connect the waste tube to the EMPV of the pump

Unpack and install the micro degasser

- Place the micro degasser on top of the pump
- Connect the power cable
- Connect the solvent tube G1322-67300 between the outlet port of the degasser and the solvent selection valve of the pump

Unpack and install the solvent cabinet

- Place the solvent cabinet on top of the degasser
- Place the bottles in the solvent cabinet
- At the bottle head assembly G1311-60003 replace the glass solvent inlet filter with a stainless steel (SST) solvent inlet filter 01018-60025
- Connect the bottle head assembly to the inlet port of the degasser
- Connect the tube from the peristaltic flush pump to the solvent bottle in the solvent cabinet

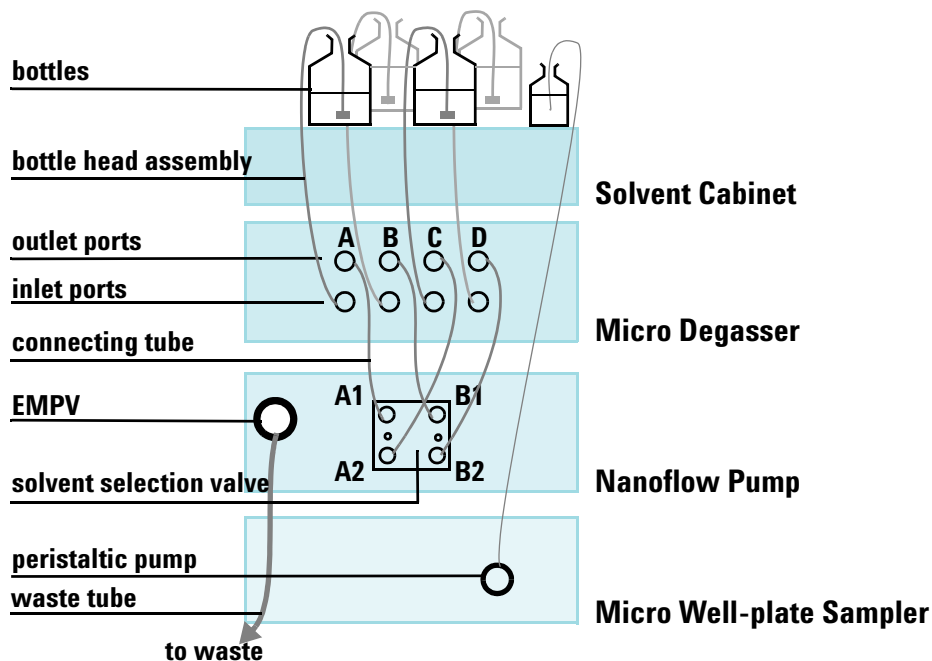

Figure 1 Stacking Overview

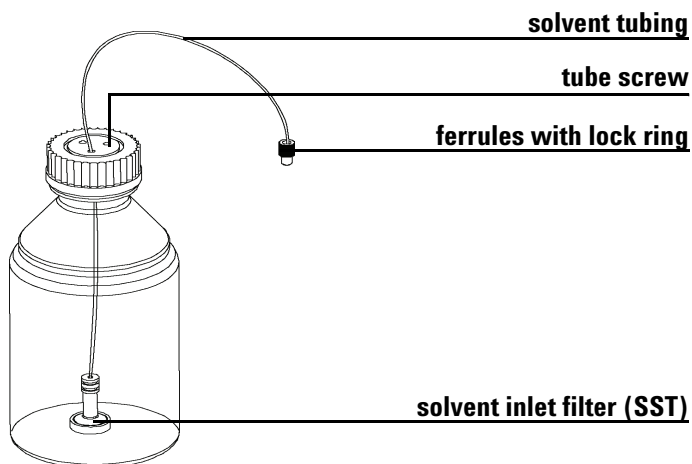

Figure 2 Bottle Head Assembly - Overview

Preparing the System

Preparing Solvent

Purging the System

Plumbing the System

Operating tips
see page 10

Installation Step How to Proceed

Prepare solvent

- Prepare 0.1% HCOOH in H₂O for channel A
- Prepare 0.1% HCOOH in CH₃CN for channel B
- Prepare 15% CH₃OH, 84% H₂O, 0.1% HCOOH for the wash solvent of the Well-plate Sampler needle

Purge

- Turn **ON** the micro degasser and the pump
- Connect the handheld controller to the pump
- Activate the purge mode by selecting: **Welcome screen/ Control/Nano pump purge task** at the handheld controller
- Set the flow to 2.5 ml/min and purge each channel separately for 4 minutes.
- Switch to 50/50 A/B and purge for additional 4 minutes

Connect the capillaries

This complete procedure can take more than one hour. For best performance, it is important to condition the capillaries as described below. If the pressure and flow do not stabilize in the given times, there are probably particles lodged in the front of the capillaries involved. Backflush the capillaries to remove the particles.

- Turn on the Micro Well -plate Sampler.
- Connect the capillary G1375-87322 to the outlet of the Nano Pump flow sensor. The other end of this capillary should be placed over a paper towel or over a beaker.
- **Condition this newly installed capillary as described in the section "How to condition a capillary" on the next page.**
- Stop the pump.
- Connect the outlet of capillary G1375-87322 to port #1 of the Micro Well-plate Sampler valve (see figure 3).
- Replace the seat capillary (capillary #4, figure 3) with the 75 µm seat capillary G1375-87316 found in the Nano Pump accessory kit.
- Connect the capillary G1375-87323 (capillary #6, figure 3) to port#6 of the Micro Well-plate Sampler valve. The other end of this capillary should be placed over a paper towel or over a baker.
- **Condition this newly installed capillary as described in the section "How to condition a capillary" on next page.**

How to condition a capillary in the system

- Pump in normal mode 50% B as long it takes for the pressure to become stable. Pump at least 10 minutes before continuing.
- Pump 4 $\mu\text{l}/\text{min}$, micro mode, 50% B, primary flow set to low solvent composition range. Pump for as long as it takes for the pressure to become stable. Pump at least 10 minutes before continuing.

NOTE

The pressure drop in the capillary is function of the capillary diameter and length, the flow rate and the solvent. Depending on the flow path configuration the system pressure can be lower than 20 Bar. In this case the nano pump can have some difficulties to regulate correctly in micro mode.

Additional Installation Notes

In the purge mode, the flow goes to waste rather than through the analytical system. You will not damage the system by using the purge mode at 2.5 ml/min.

Purging the system is necessary if:

- It is being used for the first time.
- It was switched **OFF** overnight or longer.
- The vacuum degasser lines are empty.
- You have changed to a solvent that is immiscible with the previous solvent.

- Install one capillary after the other and wait for stable pressure and flow in micro mode before connecting the next capillary.
- Avoid air gaps between fittings.
- Do not overtighten, trap (in module doors), or bend capillaries with radius smaller than 4 cm.
- Always install and retighten without flow.
- Use pH below 9.

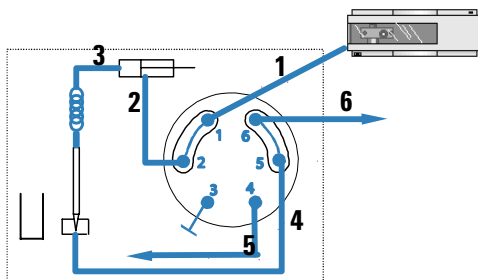

Figure 3 Plumbing diagram (main pass)

Checkout Procedure

Checkout Procedure

Equipment

• G2226A	Nano Pump
• G1377A	Micro Well-plate Sampler (WPS)
• G1379B	Micro Degasser
• G2226-67300	Nano Flow Restriction Capillary
• Channel A1	Water
• Channel B1	Acetonitrile
• Channel A2	Isopropanol

Preparing System

How to Proceed

- 1 Check the system tightness by executing a micro pressure test, with the plug on port 6 of the injection valve in the Micro Well-plate Sampler. (If you take the decision to do the micro pressure test with water instead of IPA, note that the test can fail).
- 2 Purge channel A1 with 100% water at 2.5 ml/min for 2 minutes.
- 3 Purge channel B1 with 100% acetonitrile at 2.5 ml/min for 2 minutes.
- 4 Pump 10 µl/min, normal mode, 100% A (water). Pump as long as it takes for the pressure to become stable. Pump at least 5 more minutes before continuing.
- 5 Pump 10 µl/min, normal mode, 100% B (acetonitrile) . Pump as long as it takes for the pressure to become stable. Pump at least 5 more minutes before continuing.
- 6 Install the restriction capillary G2226-67300 on port #6 of the injection valve in the Micro Well-plate sampler.
- 7 Pump 1.5 µl/min, micro mode, 70% A (water) / 30% B (acetonitrile). Pump as long as it takes for the pressure to become stable. Then pump for at least 5 more minutes before continuing.
- 8 Pump 0.6 µl/min, micro mode, 70% A (water) / 30% B (acetonitrile). Pump as long as it takes for the pressure to become stable. Then pump for at least 5 more minutes before continuing.

Method Parameters

Checkout Procedure

Method Parameters

Method Parameters

Nano Pump

Column flow	0.6 $\mu\text{l}/\text{min}$	Solvent A	70% Water
Primary flow	200-500 $\mu\text{l}/\text{min}$	Solvent B	30% ACN
Calibration	H ₂ O / ACN	Compressibility A	50 $\times 10^{-6}/\text{Bar}$
Stoptime	15 minutes	Compressibility B	115 $\times 10^{-6}/\text{Bar}$
Min. Stroke A and B	Auto	Fast composition change timetable	ON

Time (min)	0.00	3.00	3.01	6.00	6.01	9.00	9.01	12.00	12.01	15.00
Flow ($\mu\text{l}/\text{min}$)	0.6	0.6	0.3	0.3	0.6	0.6	0.3	0.3	0.6	0.6

NOTE

With Agilent ChemStation revision A.10.01 or higher, verify that the injection valve is set to **Bypass** in the **set injection valve** box of the WPS injector configuration dialog.

Expected Results

Checkout Procedure

Expected Results

Test Results and Evaluation

Typical pressure in bypass mode at 600 nl/min is 100 bar and at 300 nl/min 50 bar (with the G1375-87322 capillary installed between the flow sensor and port 1 of the injection valve plus the restriction capillary installed on port 6 of the injection valve).

NOTE

Due to capillary ID tolerance the nominal pressure at 600 nl/min and 300 nl/min might be different from system to system. These differences can be up to $\pm 40\%$

The evaluation is done by a visual inspection of the test results:

- The average pressure between the different plateaus at the same flow rate must be in a range of ± 2 Bar and typically $\pm 1\%$
- The pressure at 300 nl/min should be the half of the pressure at 600 nl/min.

NOTE

If no UV detector is connected to the system you will not be able to open your test data file to review the pressure and the flow profile acquired during the run. In this case, locate the signal file `DAD1A.CH` from the directory `HPCHEM/1/DATA/DEMO/ISOCRA.D` and copy to the directory for your checkout test data file before opening the file for review.

If the test results are not in the expected range, verify that the flow path is thoroughly flushed and that you have the same solvent in the complete flow path. The flow rate for a nano pump is very low compared to the volume of the flow path and several hours may be necessary to fill the system with a unique solvent depending on the configuration.

If all precautions have been taken and the results of the checkout procedure still not match the expected results, consult the troubleshooting section in the G2226-90110 Nano Pump Service Manual.

Typical Flow and Pressure Plots for the Checkout Procedure

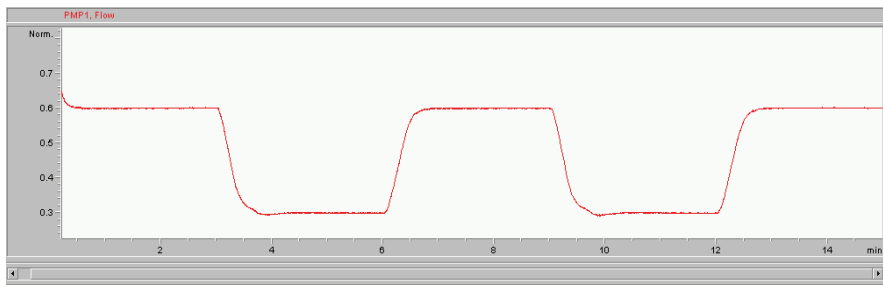

Figure 4 Flow plot

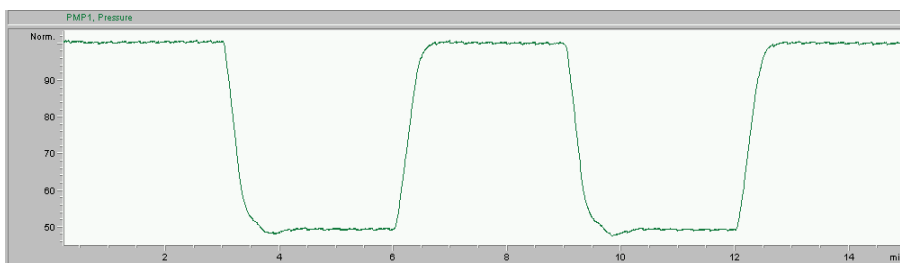

Figure 5 Pressure plot

Operation - Tips and Hints

System

- The system pressure of your newly installed system should be 40 - 50 bar under typical conditions (300 nL/min of water with a 50 x 0.075 mm, 3.5 µm column).
- For stable flow, the system pressure must be higher than 20 bar at the pump outlet.
- Check for plugged column capillaries if pressure increases more than 30 %
- For best results, use nanoflow rates from 0.1 µL/min to 1 µL/min.
- In micro mode abnormally high column flow variations are an indication of small particles within the system.
- When using buffer solutions, flush the system with water before switching it off.

Capillaries

- Flush new capillaries before connecting to other components. Wash both ends with organic solvent and be sure the connection is dry before connecting.
- Always install or retighten without flow.
- Do not overtighten, trap (in module doors) or bend with radius smaller than 4 cm.
- Avoid gaps within fittings.
- Use pH lower than 9.
- Replace capillaries if they are bent just after the fitting or anywhere else with a diameter below 4 cm.
- Compare capillary pressure drop to that listed in [Table 2](#). Replace capillary if you have more than 30 % deviation.
- Inspect suspicious capillaries under microscope. Replace those with milky surface.

Vials

The choice of glass versus plastic vials is sample-dependent. If you experience sample recovery problems, you may want to try a different type of vial. Use the following hints as a guidance:

- Plastic vials are most commonly used.
- Polypropylene inserts and wide mouth vials are recommended.
- Plastic capillary electrophoresis sample vials (300 µL, 9301-0978) can work, but they are opaque and tend to get an air bubble at the bottom of the vial. Air bubbles can cause injection problems.
- Conical polypropylene inserts (100 µL, 5182-05449) are less opaque and less prone to persistent air bubbles at the bottom.

Pump/Degasser

- Use primary flow rate for low solvent consumption.
- After changing solvents, purge each channel for 4 min.
- Check pressure drop of solvent filter in front of the EMPV once a month.
- After sitting idle for a day or longer, flush each channel for a few minutes.
- System backpressure should be higher than 20 bar.
- Irregular flow/pressure fluctuations indicate partially blocked capillaries.
- Regular fluctuations indicate air within the high pressure path.
- Rotate EMPV valve once while under flow to remove dirt from the valve seat.
- Use clean solvent bottles and solvent.
- Never run without solvent inlet filters.
- Use glass bottled solvents.
- Filter solvents through 0.4 µm filters.
- The default settings (compressibility, flow sensor calibration) are set for water in channel A and acetonitrile in channel B.

Well-plate Sampler (WPS)

- The recommended solvent for automatic washing of the autosampler needle is 15% methanol, 84,9% water, 0,1% formic acid.
- Use needle wash.
- Check alignment once a month.
- Ensure comparable pressure drop in a mainpass and bypass once a week.
- Use **bottom sensing** when working with low sample volume.
- For direct injection use **bypass mode**. This leads to a sample transfer time between WPS and column of 3-6 min (300 nl/min).
- Prime flush pump at least once a week for one minute. Check that liquid is draining from the wash port while priming.

Part Information

Table 1 Fittings and Ferrules





Fitting Type	Name	Description	Conditioning	Part Number
A 	Swagelok	1/16" SST fitting, front and back ferrule	10/pk	5062-2418
B 	Lite Touch	4/16" SST fitting	10/pk	5063-6593
	Lite Touch	1/32" SST ferrule and lock ring	10/pk	5065-4423
C 	Rheodyne	M4 PEEK fitting	6 fitt/2 plug	5065-4410
D 	Finger Tight	Double winged nuts and 1/32" ferrules	10/pk	5065-4422

Table 2 Capillaries and Fittings (for item numbers: see [Figure 3](#))

Item	Fitting type	Material	Diameter (µm)	Length (mm)	Volume (nl)	Pressure-drop for 2µl/min H ₂ O (bar)	Part Number
1	D/C	PFS	25	350	172	15	G1375-87322
2		PFS	100	200	1570		G1375-87312
3	B/D	PFS	100	1100	8639		G1375-87315
4		PFS	100	150	1178		G1375-87317
4		PFS	75	150	663		G1375-87316
5	C/-			2000			G1375-87326
6	D/C	PFS	25	550	270	23	G1375-87323
6	D/C	PFS	25	350	172	15	G1375-87322
Restriction Capillary			25	8000	3927	280	G2226-67300



G2226-90013

Part Number: **G2226-90013**

Edition 06 / 2010
Printed in Germany

© Agilent Technologies, Inc. 2010
Agilent Technologies
Hewlett-Packard-Strasse 8
76337 Waldbronn, Germany